

NRGT 26-2

## Level Transmitter

### NRGT 26-2

#### Description

##### Use as a water level controller

The NRGT 26-2 level transmitter can be used to continually measure the water level in pressurized steam and hot-water plants, or in condensate and feedwater tanks. The calibrated measuring range from 0% to 100% constitutes the linear profile of the 4-20 mA current output.

- With a suitable level controller, the transmitter's 4-20 mA actual value output can be used as a water level controller with MIN/MAX alarm, for example.
- Level transmitters are installed on the inside of pressurized steam boiler plants, tanks, feed lines of hot-water plants, or in external level pots. A protective tube installed on site ensures reliable function.
- A capacitive NRGT 26-2 level transmitter can be installed in the same protective tube or level pot as a conductive NRG 1x-50 or NRG 1x-51 level electrode.

##### Influence of the fluid to be monitored

The NRGT 26-2 level transmitter can be used in fluids with different conductivity. However, a conductivity of less than 100  $\mu\text{S}/\text{cm}$  has a major influence on the measured capacitance, which is why recalibration of the measuring range at the operating point and after a cold start is extremely important.

To achieve the best possible reproducibility and maintain measurement quality (see "Technical data"), the sensor must be installed in a protective tube or level pot.

#### Function

##### Transmitter function

The transmitter function is the ability of the electrode to provide a scalable measuring range on the 4-20 mA current output interface and to make this available to one or more recipients for analysis.

These devices do not have any controlling or limiting functions.

##### Behavior in normal operation (no faults)

The transmitter displays the scaled level reading (3 digits + 1 decimal place), e.g., 050.3, and converts the level data into a level-dependent current signal from 4-20 mA.

##### Behavior in the event of malfunctions

The error state or malfunction is indicated by an error code shown continuously on the display, e.g., E.005.

Every time there is a malfunction, 0 mA is output via the current output.

##### Setting parameters and changing default settings.

Parameters can be set and default settings changed using a rotary knob on the terminal box.

##### Display and signals

The NRGT 26-2 level transmitter has a green 4-digit, 7-segment display for showing readings, status information and error codes. A red and a green LED indicate the operating status.

#### Technical data

##### Design and mechanical connection

- NRGT 26-2: Thread  $\frac{3}{4}$  - 14 NPT

##### Permitted service pressure and temperature

- NRGT 26-2: 464 psi at 460 °F (32 bar at 238 °C)

##### Materials

- Terminal box: 3.2581 G AISi12, powder-coated
- Cover tube: 1.4301 X5 CrNi 18-10
- Electrode rod insulation: PTFE
- Screw-in body: 1.4404 / F316L

##### Max. electrode length at 460 °F (238 °C)

- See "Available lengths", tables in Fig. 1 and Fig. 2
- Do **not shorten** the electrode rod.

##### Measurement quality

The information below applies to a compensated fluid conductivity range from 100 – 10000  $\mu\text{S}/\text{cm}$  based on 77 °F (25 °C).

- Reading error: +/- 1% of set measuring range at the operating point
- Resolution of reading on display: 0.1%
- Resolution for internal processing: 15 bits with plus or minus sign (16 bits)
- Resolution of 4-20 mA output: 15 bits equivalent to 0.49  $\mu\text{A}/\text{digit}$

##### Supply voltage

- 24 V DC +/-20% SELV / PELV / CLASS2

##### Power consumption

- Max. 7 W

##### Current input

- Max. 0.3 A

##### Internal fuse

- T2A

##### Safety cutout at excessive ambient temperature

- Cutout takes place at an excessive ambient temperature of  $T_{\text{amb.}} = 167$  °F (75 °C)

##### Analog output

- 1 actual value output 4 - 20 mA, proportional to level, galvanically isolated
- Maximum output load 500  $\Omega$
- M12 connector, 5-pole, A-coded

# Level Transmitter NRGT 26-2

## Indicators and controls

- 1 green 4-digit, 7-segment display for showing status information
- 1 red LED for indicating the error state
- 1 green LED for indicating the OK state
- 1 rotary knob IP65 with button for menu navigation and test function

## Protection class

- III Safety Extra Low Voltage (SELV / PELV / CLASS2)

## IP rating

- NEMA type 3R, 3RX, 5 to NEMA 250
- IP 65 to EN 60529

## Permitted ambient conditions

- Service temperature: 32 - 158 °F (0 - 70 °C)
- Storage temperature: -40 - 176 °F (-40 - 80 °C)
- Transport temperature: -40 - 176 °F (-40 - 80 °C)
- Air humidity: 10% - 95% (non-condensing)

## Weight (dependent on length of electrode)

- NRGT 26-2 approx. 3.96 lb (1.8 kg)  
(with 11.81 inch (300 mm) measuring range)

## Permitted installation positions

- Vertical
- Maximum inclination of 45°. In this case, the length of the electrode rod is limited to maximum 27.1 inch (688 mm).

## Applicable directives:

The NRGT 26-2 level transmitter has been tested and approved for use in the scope governed by the following directives and standards:

- UL 60730-1 and CAN/CSA E60730-1  
General Requirements for Automatic Electrical Controls
- UL 60730-2-15 and CAN/CSA E60730-2-15  
Requirements for Automatic Electrical Water Level Sensing Controls

## Improper use

There is a danger of death due to explosion if the equipment is used in potentially explosive atmospheres.  
Do not use the equipment in potentially explosive atmospheres.

Please note our general terms of business.

## Important notes

### Installation

Adequate electrical contact between the electrode and the boiler wall must be ensured after fitting the electrode with PTFE sealing tape.

The contact resistance between the electrode housing and the boiler must be <10 ohms. If it is not, a conductive connection to the boiler must be produced using a band grounding clamp on the electrode.

### Electrical connection

Use a shielded, multi-core TC-ER control cable with minimum wire size AWG 18, e.g., ÖLFLEX® CONTROL TM CY 5G1.

The NRGT 26-2 level transmitter is supplied with 24 V DC.

A safety power supply unit that delivers a Safety Extra Low Voltage (SELV / PELV / CLASS2) and is isolated from connected loads must be used to supply the equipment with 24 V DC.

### Connecting the actual value output (4 - 20 mA)

Please note the maximum output load of 500 Ω.

Maximum cable length = 328 feet (100 m).

Cable jack Binder series 713 99-0436-58-05

## Available lengths:

### Level transmitter 26-2

#### Order solely via material number

| ① = electrode length (mm) |                    | ② = measuring range (mm) |   |
|---------------------------|--------------------|--------------------------|---|
| ①                         | ②                  | ①                        | ② |
| 14.70 in (373 mm)         | 11.80 in (300 mm)  |                          |   |
| 18.80 in (477 mm)         | 15.75 in (400 mm)  |                          |   |
| 22.95 in (583 mm)         | 19.70 in (500 mm)  |                          |   |
| 27.10 in (688 mm)         | 23.65 in (600 mm)  |                          |   |
| 31.25 in (794 mm)         | 27.60 in (700 mm)  |                          |   |
| 35.40 in (899 mm)         | 31.50 in (800 mm)  |                          |   |
| 39.55 in (1004 mm)        | 35.50 in (900 mm)  |                          |   |
| 43.70 in (1110 mm)        | 39.37 in (1000 mm) |                          |   |
| 47.80 in (1214 mm)        | 43.30 in (1100 mm) |                          |   |
| 51.95 in (1319 mm)        | 47.25 in (1200 mm) |                          |   |
| 56.05 in (1423 mm)        | 51.20 in (1300 mm) |                          |   |
| 60.20 in (1528 mm)        | 55.10 in (1400 mm) |                          |   |
| 64.45 in (1636 mm)        | 59.05 in (1500 mm) |                          |   |
| 84.90 in (2156 mm)        | 78.75 in (2000 mm) |                          |   |

Fig. 1

### NRGT 26-2 additional modules:

- Level controller: NRR 2-50, NRR 2-51 or NRR 2-52, NRR 2-53 with URB 55
- Power supply unit: SITOP PSU100C 24V/0.6A

## NRGT 26-2 dimensions

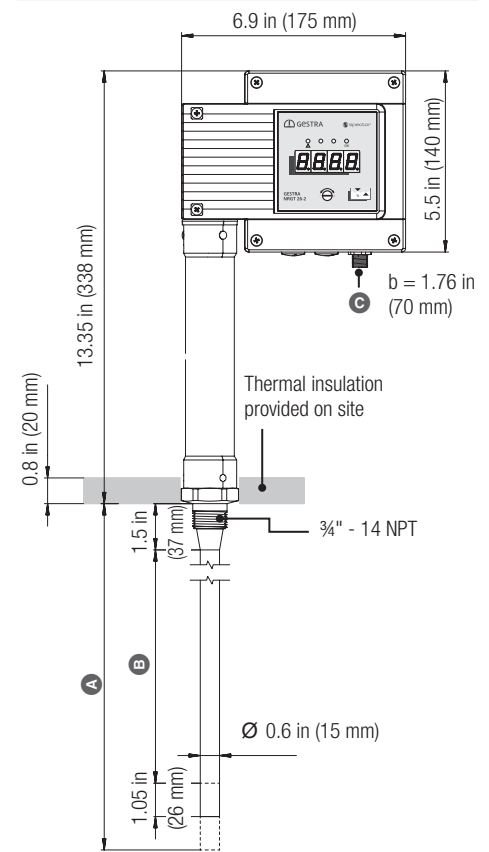

Fig. 2  
 A Maximum electrode length at 460 °F (238 °C)  
 B Measuring range  
 see table Fig. 1

## Connections

- M12 connector, 5-pole, A-coded

# GESTRA AG

Münchener Strasse 77, 28215 Bremen, Germany  
 Tel. +49 421 3503 0, Fax +49 421 3503 393  
 e-mail info@de.gestra.com, website www.gestra.com

