



Level Electrodes

NRG 16-51

NRG 17-51

NRG 19-51

EN (USA)
English

Original Installation &
Operating Manual

850692-00

Contents

Content of this Manual	4
Scope of supply, product package.....	4
How to use this Manual.....	5
Illustrations and symbols used.....	5
Hazard symbols in this Manual.....	5
Types of warning	6
Specialist terms, abbreviations	7
Usage for the intended purpose.....	8
Applicable directives and standards.....	8
Admissible system components.....	8
Improper use	8
Basic safety information	9
Required personnel qualifications.....	10
Notes on product liability	10
Function	11
Technical data	12
Rating plate, identification.....	13
Overall view of the NRG 16-51, NRG 17-51, NRG 19-51	14
Dimensions of the NRG 16-51, NRG 17-51, NRG 19-51 with four-pole connector	15
Overall view of the NRG 16-51F, NRG 17-51F, NRG 19-51F.....	16
Dimensions of the NRG 16-51F, NRG 17-51F, NRG 19-51F with aluminum terminal box.....	17
Preparing for installation	18
Installation.....	19
Installing the NRG 16-51, NRG 17-51, NRG 19-51, step 1	21
Installing the NRG 16-51, NRG 17-51, NRG 19-51, step 2	22
Installing the NRG 16-50F, NRG 17-50F, NRG 19-50F with aluminum terminal box	23
Installing the NRG 16-50F, NRG 17-50F, NRG 19-50F, additional information	24

Contents

Installation examples with dimensions	25
Electrical connection	27
NRG 16-50, NRG 17-50, NRG 19-50 with four-pole connector.....	27
Connecting the level electrode.....	28
NRG 16-50, NRG 17-50, NRG 19-50 with four-pole connector.....	28
NRG 16-50F, NRG 17-50F, NRG 19-50F with aluminum terminal box.....	28
Wiring diagram.....	29
Bringing into service, fault indications and troubleshooting	30
Taking out of service	30
Removing the NRG 1..-51 level electrode.....	30
Removing the NRG 1..-51F level electrode.....	30
Disposal	31
Returning decontaminated equipment	31
UL components	31

Content of this Manual

Product:

- Level Electrodes NRG 16-51, NRG 17-51, NRG 19-51

First edition:

BAN 850692-00/08-2021cm

© Copyright

All rights reserved. Any misuse, particularly reproduction and dissemination to third parties, is not permitted. The General Terms & Conditions of GESTRA AG apply.

Scope of supply, product package

NRG 16-51

- 1 level electrode NRG 16-51
- 1 washer with set screw
(enlarged measuring surface) (optional)
- 1 retaining ring (optional)
- 1 Installation & Operating Manual

NRG 17-51

- 1 level electrode NRG 17-51
- 1 washer with set screw
(enlarged measuring surface) (optional)
- 1 retaining ring (optional)
- 1 Installation & Operating Manual

NRG 19-51

- 1 level electrode NRG 19-51
- 1 washer with set screw
(enlarged measuring surface) (optional)
- 1 retaining ring (optional)
- 1 Installation & Operating Manual

How to use this Manual

This Installation & Operating Manual describes the correct use of NRG 1..-51 level electrodes. It applies to persons who integrate this equipment in control systems, install, bring into service, operate, maintain and dispose of this equipment. Anyone carrying out the above-mentioned activities must have read this Installation & Operating Manual and understood its contents.

- Read this Manual in full and follow all instructions.
- Please also read the instructions for use of any accessories.
- The Installation & Operating Manual is part of the product package. Keep it in an easily accessible location.

Availability of this Installation & Operating Manual

- Make sure this Installation & Operating Manual is always available to the operator.
- If you pass on or sell the equipment to a third party, please also hand over the Installation & Operating Manual.

Illustrations and symbols used

1. Action to be taken
- 2.

-
- Lists
 - ◆ Bullet points in lists

A Keys to illustrations



Additional information



Read the relevant Installation & Operating Manual

Hazard symbols in this Manual



Danger zone, dangerous situation

Types of warning

DANGER

Warning of a dangerous situation that results in death or serious injury.

WARNING

Warning of a dangerous situation that may possibly result in death or serious injury.

CAUTION

Warning of a situation that may result in minor or moderate injury.

ATTENTION

Warning of a situation that results in damage to property or the environment.

Specialist terms, abbreviations

Here, we explain some abbreviations, specialist terms, etc., which are used in this Manual.

NRGT .. / NRR.. / NRS.. / URS .. / URB .. / SRL .. / etc.

Equipment and type designations of GESTRA AG.

SELV

Safety Extra Low Voltage

Operating point (of the plant)

The operating point describes the operating parameters within which a plant or boiler is operated in its nominal range. In a steam boiler, for example, these parameters would be output, pressure, and temperature.

The design data may be a lot more stringent, however.

A boiler that is operated at 145 psi (10 bar) and 356°F (180°C) may be designed to withstand a pressure of 870 psi (60 bar) and a temperature of 527°F (275°C), for example, which is therefore not necessarily its operating point.

Usage for the intended purpose

NRG 1...-51 level electrodes are used in conjunction with the NRS 1-51 level switch as a high-level alarm for steam boilers and hot water installations.

A high-level alarm prevents the defined high water (HW) level from being exceeded and switches off the feedwater supply, for example, to achieve this.

Applicable directives and standards

The equipment has been tested and approved for use in the scope governed by the following directives and standards:

Standards:

- UL 60730-1 and CAN/CSA E60730-1
General Requirements for Automatic Electrical Controls
- UL 60730-2-15 and CAN/CSA E60730-2-15
Requirements for Automatic Electrical Water Level Sensing Controls

Admissible system components

According to UL 60730-2-15, the NRG 1...-51 level electrode can be operated with the NRS 1-51 level switch and regarded as a protective control.



To ensure proper use in all applications, please also read the Installation & Operating Manuals for the system components used.

- You can find the latest Installation & Operating Manuals for other system components on our website:
<http://www.gestra.com>

Improper use



There is a danger of death due to explosion if the equipment is used in potentially explosive atmospheres.

Do not use the equipment in potentially explosive atmospheres.



Do not bring any equipment into service that does not have its own specific rating plate.

The rating plate indicates the technical features of the equipment.

Basic safety information



Danger to life from scalding! Do not remove the level electrode under pressure. Steam or hot water can spurt forcefully out of the equipment.

- Only remove the level electrode at **0 psi (0 bar)** boiler pressure.



Risk of severe burns! Do not perform work on a level electrode that is still hot. The level electrode gets very hot during operation.

- Allow the level electrode to cool.
- Always wait for the level electrode to cool before performing any installation and maintenance work.



There is a risk of electric shock during work on electrical systems.

- Always switch off the voltage to the plant before performing connection work.
- Check that the plant is not carrying live voltage before commencing work.



Danger to life! Hot steam or hot water can suddenly escape from a faulty NRG 1...-51 level electrode.

Shocks and impacts during transport or installation can result in damage to or leaks in the level electrode, causing pressurized hot steam or hot water to escape through the pressure relief hole.

- To prevent damage during transport and installation, do not expose the electrode rod to major shocks or impacts.
- Before and after installation, check that the level electrode is completely undamaged.
- Check that the level electrode is not leaking when bringing into service.



Attempts to repair the equipment will cause the plant to become unsafe.

- The NRG 1...-51 level electrode may only be repaired by the manufacturer, GESTRA AG.
- Only replace faulty equipment with identical equipment from GESTRA AG.

Required personnel qualifications

Activity	Personnel	
Integration in control system	Specialist staff	Plant designer
Installation / electrical connection/ bringing into service	Specialist staff	The equipment may only be installed, wired and brought into service by qualified and competent staff.
Operation	Boiler service technician	Staff trained by the plant operator.
Maintenance work	Specialist staff	Fitting and maintenance work may only be performed by authorized staff who have undergone specific training.
Refits	Specialist staff	Persons trained by the plant operator to work with pressure and temperature.

Fig. 1

Notes on product liability

The manufacturer cannot accept any liability for damages resulting from improper use of the equipment.

Function

When the water exceeds the high water level, the level electrode is immersed and an alarm is triggered in the NRS 1-51 level switch. This "High water (HW) exceeded" switchpoint is determined by the length of the electrode extension.

The level electrode uses the conductivity of the water to measure the water level, and is self-monitoring, i.e. an alarm is also triggered if the electrode insulator is leaking or contaminated and/or there is a fault in the electrical connection.

Please note that a suitable protective tube needs to be provided on site during installation to ensure safe operation. One NRG 1...-51 level electrode can be installed in a single protective tube or level pot together with a GESTRA level electrode for water level limitation.

If the level electrode is installed in a level pot outside the boiler, the connection pipes must be flushed regularly. The manufacturer recommends connection pipes of ≥ 1.57 in (40 mm) for steam and ≥ 3.94 in (100 mm) for water. If smaller connection pipes are used, these must have a minimum NPS of 1 inch. The level pot must have a suitable flushing device at its lowest point. This device flushes the connection pipes to the boiler and enables the function of the water level limiter to be tested. No shut-off valves of any type shall be placed in the piping between the boiler and the low water cutoff.



Danger

Please note that a suitable protective tube needs to be provided on site for an electrode installed internally, to ensure safe operation. Please exercise caution when flushing the system, as outflowing boiler water or flash steam can lead to scalding. Please wear suitable protective clothing and do not touch any hot surfaces.

Safety information

The equipment is part of a protective control according to UL 60730-1 and may only be installed, electrically connected and brought into service by qualified and competent staff.

Fitting and maintenance work may only be performed by authorized staff who have undergone specific training.



Attention

The rating plate indicates the technical features of the equipment. Do not bring into service or operate any equipment that does not bear its own specific rating plate.

Technical data

NRG 16-51, NRG 17-51, NRG 19-51

Service pressure

NRG 16-51: 464 psi at 460 °F (32 bar at 238 °C)

NRG 17-51: 667 psi at 500 °F (46 bar at 260 °C)

NRG 19-51: 1450 psi at 592 °F (100 bar at 311 °C)

Mechanical connection

Thread 1" - 11.5 NPT

Materials

Screw-in body 1.4404/ F316L

Measuring electrode 1.4571, X6CrNiMoTi17-12-2

Electrode extension 1.4401, X5CrNiMo17-12-2

Electrode insulation PEEK

NRG 1...-51: Four-pole connector, polyamide (PA)

NRG 1...-51F: Terminal box 3.2161 G AISi8Cu3

Lengths supplied

19.68 in (500 mm), 39.37 in (1000 mm), 59.05 in (1500 mm)

Electrical connection

NRG 1...-51: Four-pole connector, cable glands M 16

NRG 1...-51F: Aluminum terminal box, cable gland M 20

Protection

IP 65 according to EN 60529

NRG 1...-51: NEMA type 1 according to NEMA 250

NRG 1...-51F: NEMA type 4 according to NEMA 250

Admissible ambient temperature

Max. 158 °F (70 °C)

Weight

Approx. 2.65 lb (1.2 kg) (without extension) (NRG 16-51, NRG 17-51, NRG 19-51)

Approx. 4.63 lb (2.1 kg) (without extension) (NRG 16-51F, NRG 17-51F, NRG 19-51F)

Other information

Incorporated type 1 action operating control

Pollution degree 3, impulse voltage 330 V

Rating plate, identification

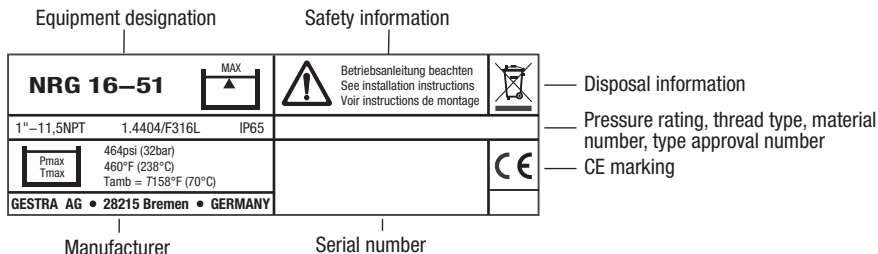

Fig. 1

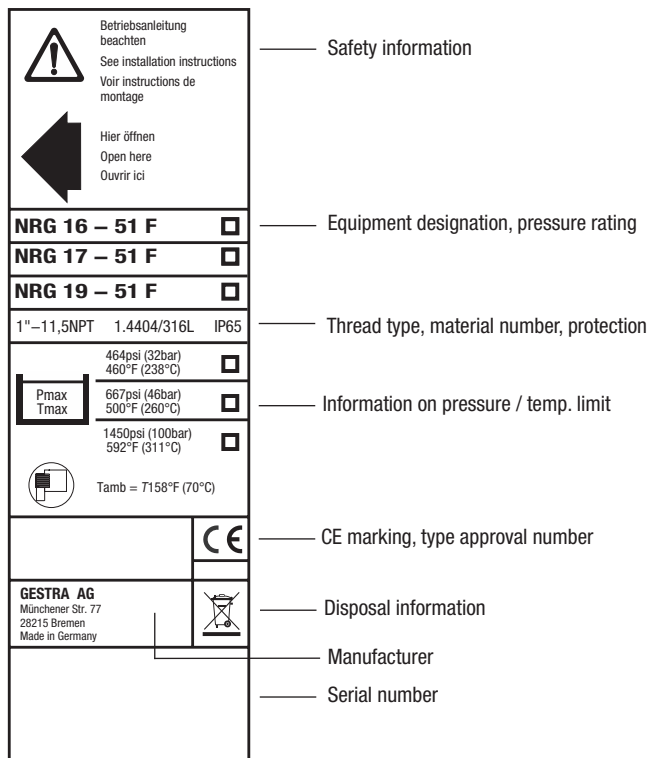

Fig. 2

	Input rating: Up to 5VAC
	Ambient temperature: 32-158°F (0-70°C)
	Environmental rating: NEMA 4 / 4X / 12
	Wiring: Use Copper Conductors Only, Use 60/75°C Conductors.
	Use No. 18-16 AWG Wire Size Only, Tightening: Torque 0.79 Nm or 7 lb in.
	Use with accessory: NRS1-51

Fig. 3 NRG 1...-51F

	Input rating: Up to 5VAC
	Ambient temperature: 32-158°F (0-70°C)
	Environmental rating: NEMA 1
	Wiring: Use Copper Conductors Only, Use 60/75°C Conductors;
	Use No. 18-16 AWG Wire Size Only, Tightening: Torque 0.79 Nm or 7 lb in.
	Use with accessory: NRS1-51

Fig. 4 NRG 1...-51

Overall view of the NRG 16-51, NRG 17-51, NRG 19-51

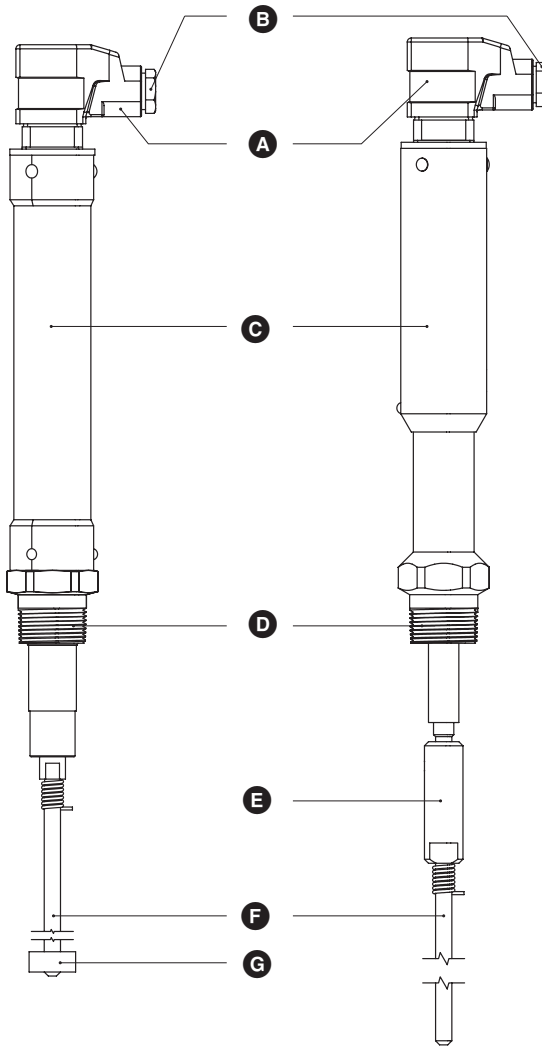

Fig. 5

Key

- | | |
|--|-------------------------------------|
| A Terminal box or four-pole connector | E Measuring electrode |
| B Cable entry | F Electrode extension |
| C Cover tube | G Enlarged measuring surface |
| D Electrode thread | |

Dimensions of the NRG 16-51, NRG 17-51, NRG 19-51 with four-pole connector

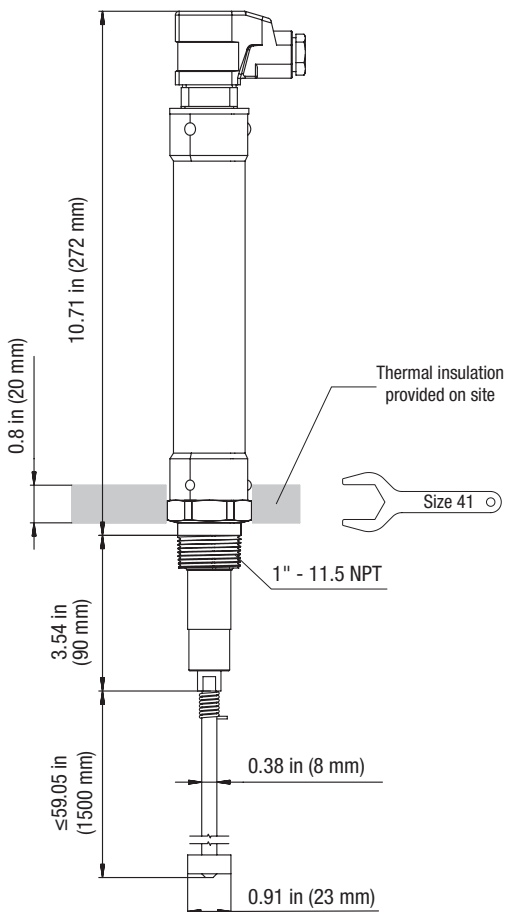

Fig. 6

NRG 16-51, NRG 17-51
with enlarged measuring surface

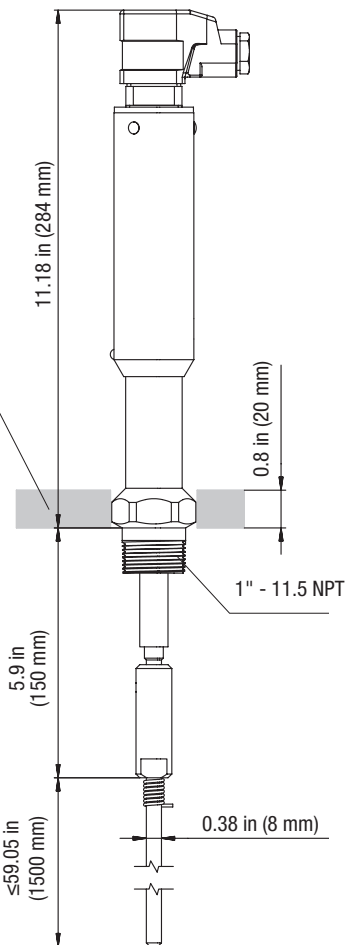

Fig. 7

NRG 19-51

Overall view of the NRG 16-51F, NRG 17-51F, NRG 19-51F

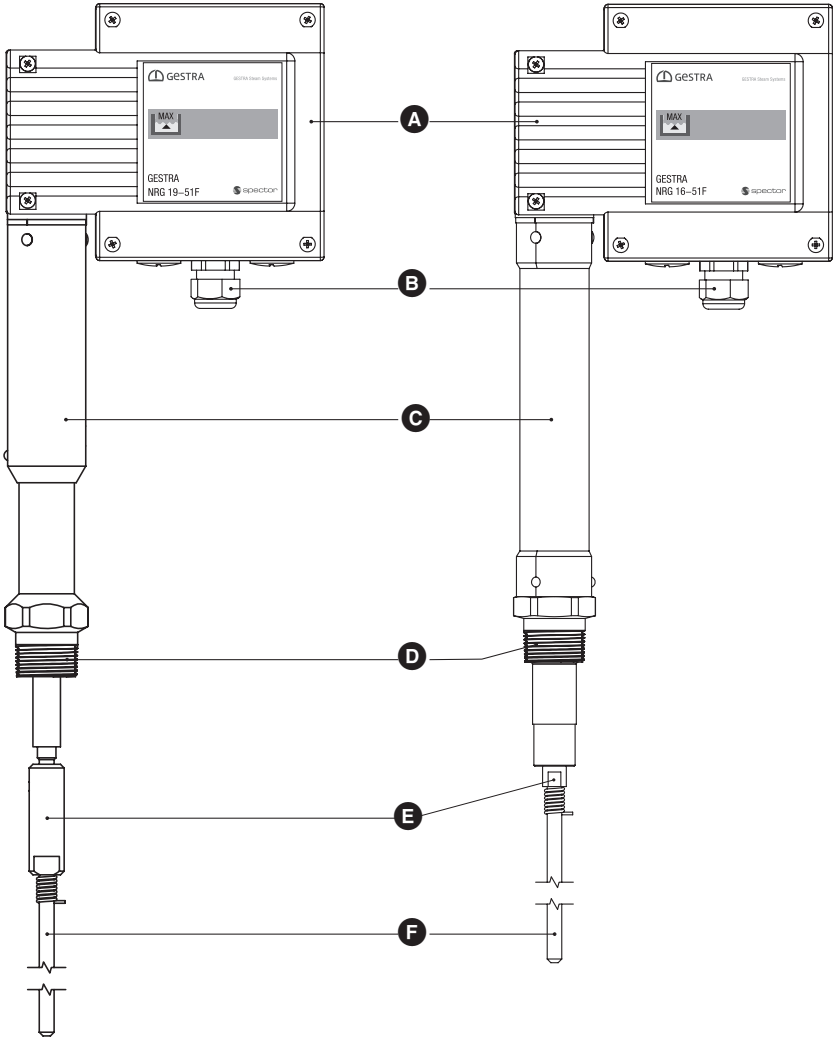

Fig. 8

Key

- | | |
|--|------------------------------|
| A Terminal box or four-pole connector | E Measuring electrode |
| B Cable entry | F Electrode extension |
| C Cover tube | |
| D Electrode thread | |

Dimensions of the NRG 16-51F, NRG 17-51F, NRG 19-51F with aluminum terminal box

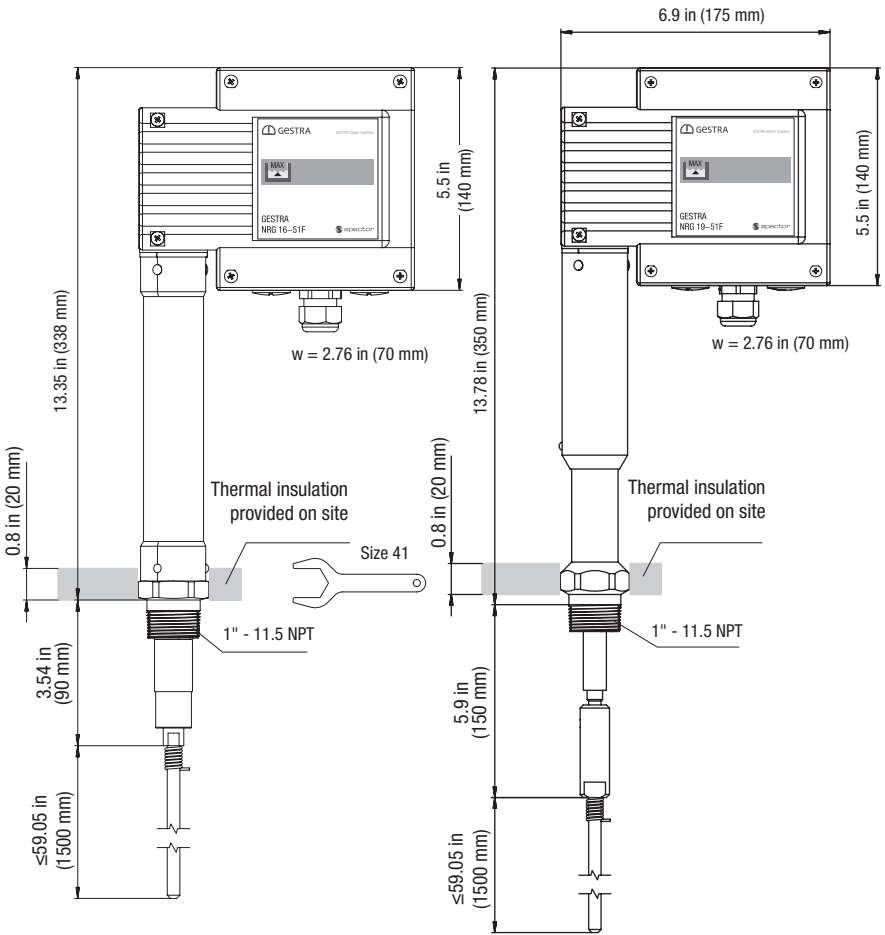

Fig. 9
NRG 16-51F, NRG 17-51F

Fig. 10
NRG 19-51F

Preparing for installation



If the equipment is to be installed outdoors, outside the protection of a building, environmental influences may adversely affect function.

- Pay attention to the permitted ambient conditions in the technical data, see page 12.
- Do not operate the equipment if the temperature is below freezing.
 - ◆ At temperatures below freezing, use a suitable heat source (e.g. control cabinet heater, etc.).
- Connect all parts of the plant to a central grounding point to prevent equalizing currents.
- Use a cover to protect the equipment from direct sunlight, condensation and heavy rain.
- Use UV-resistant cable ducts for routing the connecting cable.
- Take further measures to protect the equipment from lightning, insects and animals, and salty air.

You will need the following tools:

- Open-ended wrench size 13
- Open-ended wrench size 19
- Open-ended wrench size 41
- Scriber
- Hacksaw
- Flat file

Installation

DANGER



Danger to life! Escaped hot steam can cause scalding.

Hot steam or hot water can escape suddenly if the level electrode is unscrewed under pressure.

- Reduce the boiler pressure to 0 psi (0 bar) and check the pressure before unscrewing the level electrode.
- Only remove the level electrode at 0 psi (0 bar) boiler pressure.

WARNING



The hot level electrode can cause severe burns.

The level electrode gets very hot during operation.

- Always let the level electrode cool down before performing installation and maintenance work.
- Only remove level electrodes that have cooled down.

ATTENTION



Incorrect installation can lead to malfunctions in the plant or the level electrode.

- Take care not to bend the measuring electrode during installation!
- Do not lag the terminal head **A** or cover tube **B** (see pages 14 and 16) when thermally insulating the boiler!
- Do not coat the electrode thread with conductive paste or grease!
- Make sure there is a creepage path of at least 0.55 in (14 mm) between the electrode and ground (flange, tank wall). **Figs. 17 - 19**
- If the electrode is installed inside the vessel, it must be at least 1.57 in (40 mm) away from the pressure relief hole in the protective tube.



Note

- One NRG 1...-51 level electrode can be installed in a single protective tube or level pot (inside diameter 3.94 in [100 mm]) together with a GESTRA level electrode, a level switch or transmitter for water level control and limitation. **Fig. 18.** If a NRG 1...-50 level electrode is used (for water level limitation) and installed inside the vessel, it must be at a minimum distance of 1.57 in (40 mm) from the upper pressure relief hole.
- Check the boiler standpipe and flange during the preliminary boiler inspection.
- Installation examples can be found on pages 25 and 26.
- The electrode must not be at an incline of more than 45°, and the length of the electrode rod is limited to 39.37 in (1000 mm).
- For outdoor installations, please use the NRG 1...-51F level electrode. Type F level electrodes have an aluminum terminal box.

Installation

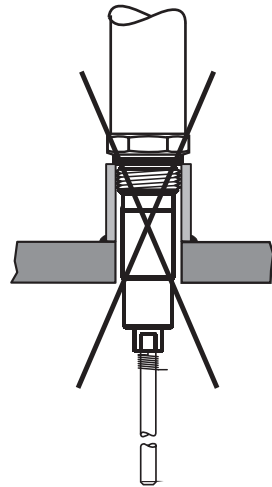
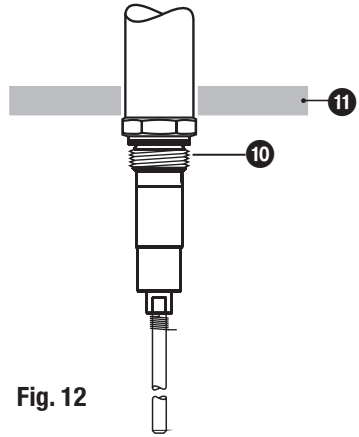
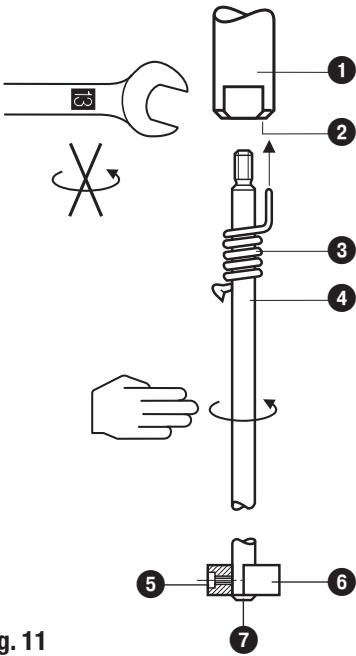

Fig. 13
NRG 16-51
NRG 17-51
NRG 19-51

Installation

Installing the NRG 16-51, NRG 17-51, NRG 19-51, step 1

1. Screw the electrode extension ④ into the measuring electrode ①. **Fig. 11**
2. Determine the required measuring length of the electrode.
3. Mark the appropriate length on the electrode extension ④ with a scriber.
4. Unscrew the electrode extension ④ from the electrode ① and cut it.
5. After a visual inspection, screw the extension ④ firmly into the electrode ①. Push the retaining spring ③ onto the electrode extension ④ until it is securely seated in the hole ②.
6. Fit the enlarged measuring surface: Push the washer ⑥ onto the enlarged measuring surface in such a way that the surface projects 0.08 in (2 mm) beyond the underside of the washer. Secure the washer with the set screw ⑤ in this position. Push the supplied retaining ring ⑦ over the electrode extension from below onto the washer ⑥.

Key

- | | |
|---------------------------------------|--|
| ① Measuring electrode | ⑩ Electrode thread |
| ② Hole | ⑪ Thermal insulation provided on site,
d=0.8 in (20 mm)
(outside thermal insulation of
steam generating unit) |
| ③ Retaining spring | |
| ④ Electrode extension | |
| ⑤ Set screw | |
| ⑥ Washer (enlarged measuring surface) | |
| ⑦ Retaining ring | |

Installation

Installing the NRG 16-51, NRG 17-51, NRG 19-51, step 2

- Make sure that the internal and external threads are in perfect condition.
- Do not apply more than three windings of PTFE insulating tape around the electrode thread.

WARNING

Do not use too much tape. Do not use fitting lubricants or pastes.

- Fit the electrode and tighten first with your hand and then with a size 41 open-ended wrench. Do not use a pipe wrench.
- Recommendations for tightening torques cannot be given due to the conical/parallel type of connection.
- Avoid tightening excessively; part of the electrode thread should always remain visible.



The electrode body does not “sit” on the flange, i.e. the underside of the hexagon is not in contact with the flange (also see **Fig. 14**). If it is in contact, the internal thread is outside tolerance. In this case, the flange must be replaced.

After the electrode has been installed with PTFE sealing tape, you must ensure there is adequate electrical contact between the electrode and the boiler wall.

To do this, after installation measure the resistance between the electrode body and the boiler with a multimeter.

The reading must be < 10 ohms.

If the reading is > 10 ohms, connect the electrode to the boiler wall using a band grounding clamp. (The band grounding clamp is available as an optional accessory)

Next, measure the resistance again.

The value must be < 10 ohms and entered as followed:

Measured resistance: _____ ohms

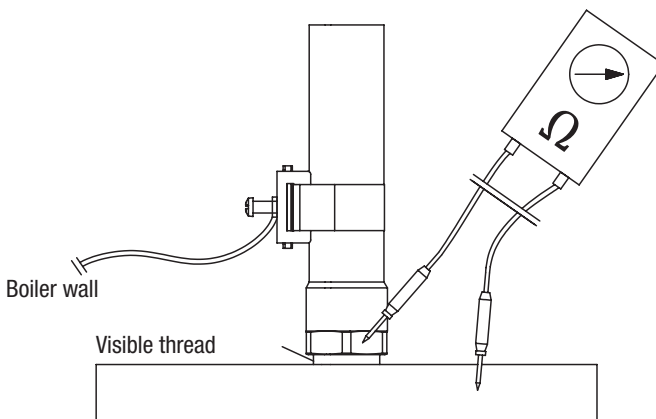
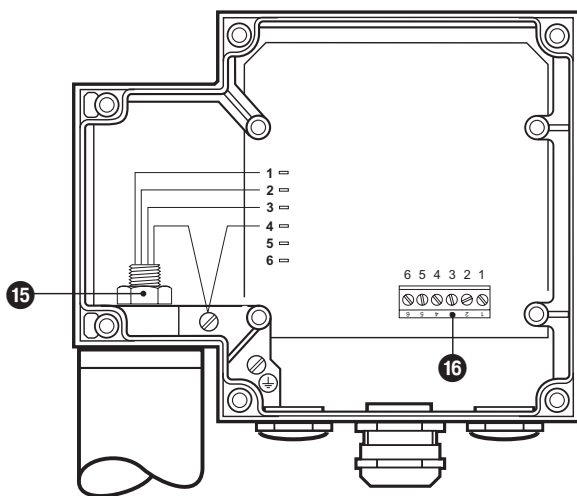
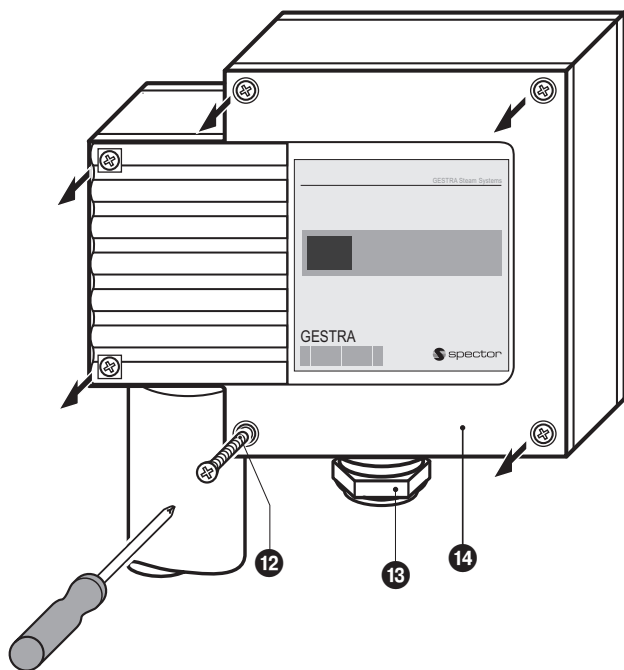

Fig. 14

Installation

Installing the NRG 16-51F, NRG 17-51F, NRG 19-51F with aluminum terminal box



Installation

Installing the NRG 16-51F, NRG 17-51F, NRG 19-51F, additional information

If you are installing an NRG 1...-51F level electrode in a protective tube or level pot together with a level electrode, level switch or transmitter (with aluminum terminal box), please note the following:

1. Install the first unit as described in the relevant Installation & Operating Manual.

Then, please note the following for installing the NRG 1...-51F level electrode:

1. Undo the screws **12** and take off the cover **14** of the terminal box. **Fig. 15**. The arrow on this cover points to the rating plate.
2. Remove the cable lugs from the pins. **Fig. 15**
3. Slacken the nut **15** using a size 19 open-ended wrench. Do not unscrew completely! **Fig. 16**
4. Screw in the level electrode as described in step 2, points 7 - 10 below.
5. Rotate the terminal box in the desired direction (+/-180 °).

The terminal box can be rotated +/-180°.

ATTENTION



Rotating the terminal box $\geq 180^\circ$ will damage the internal wiring of the NRG 16-51F, NRG 17-51F, NRG 19-51F level electrodes.

- Never rotate the terminal box more than 180° in either direction.

6. Tighten the nut **15** to **25 Nm**.
7. Push the cable lugs back onto the pins.
8. Fit the cover **14** of the terminal box and tighten the screws **12**.

Key

- 12** Terminal box screws M 4
- 13** Cable gland M 20 x 1.5
- 14** Terminal box cover
- 15** Nut
- 16** Terminal strip

Installation examples with dimensions

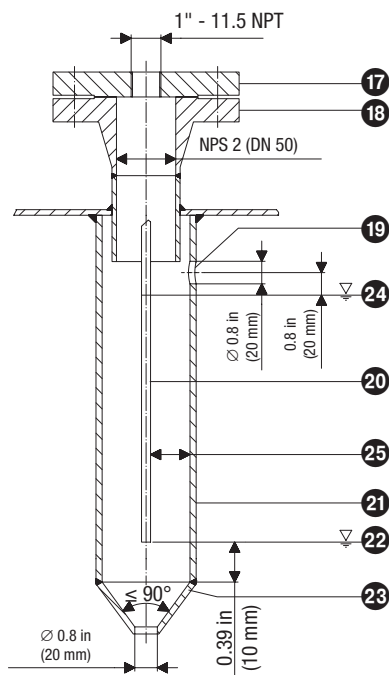

Fig. 17 Protective tube (provided on site) if electrode is used as an internal water level limiter

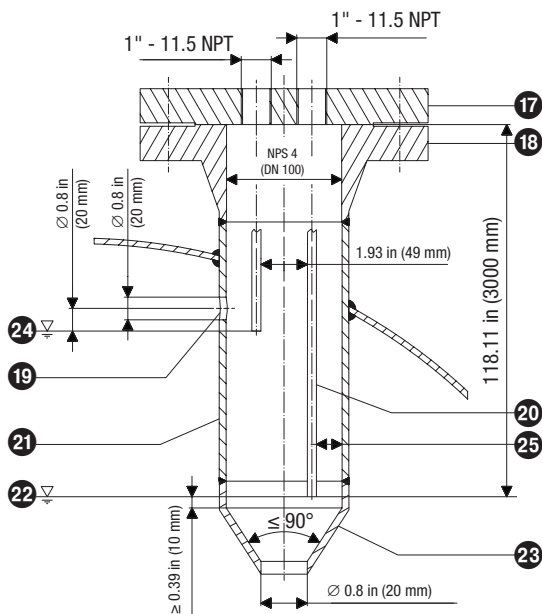

Fig. 18 Protective tube (provided on site) if electrode is used as an internal water level limiter combined with level control or high-level alarm

Installation examples with dimensions

Connecting pipe shall not be smaller than 1" NPS. No shut-off valve of any type shall be placed in the piping between the boiler and the low water cutoff.

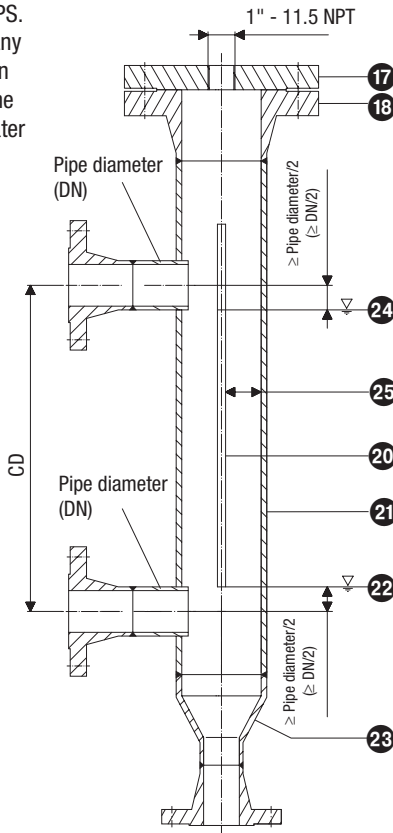

Fig. 19 Level pot if electrode is used as an external high-level alarm

Key

- | | | | |
|----|--|----|---|
| 17 | Flange NPS 2 (DN 50) NPS 4 (DN100)
(for 2 electrodes) | 22 | Low water LW |
| 18 | Perform preliminary inspection of standpipe and flange during the boiler inspection. | 23 | Reducer |
| 19 | Pressure relief hole
Locate hole as close to boiler wall as possible! | 24 | High water HW |
| 20 | Electrode rod $d = 0.32$ in (8 mm) | 25 | Electrode spacing ≥ 0.55 in (14 mm)
(air gaps and creepage paths) |
| 21 | Protective foam tube/level pot | CD | Center distance of standpipes |

Electrical connection

NRG 16-51, NRG 17-51, NRG 19-51 with four-pole connector

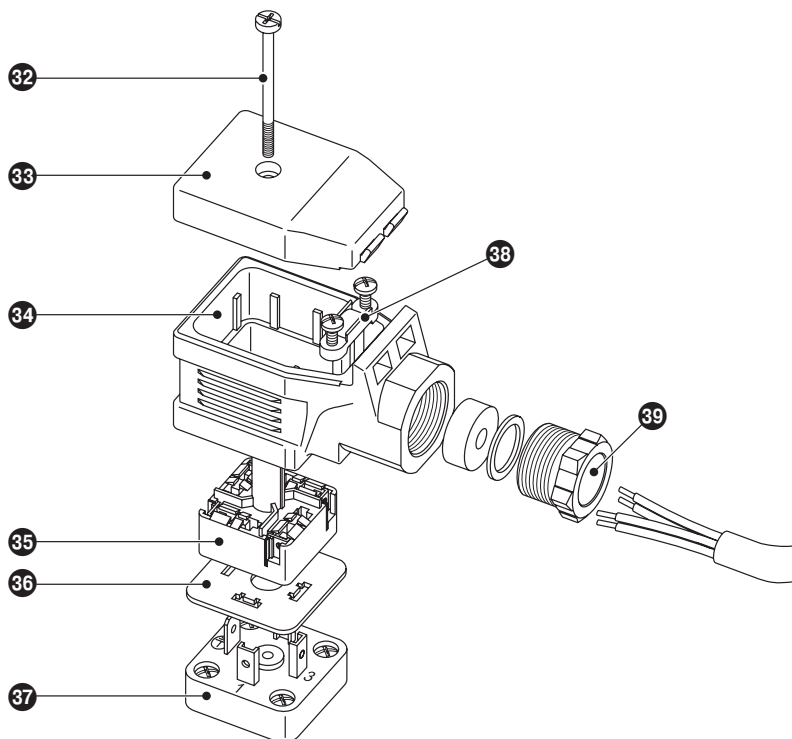

Fig. 20

Key

- | | | | |
|----|-------------------------|----|-------------------------------|
| 32 | Screw M 4 | 36 | Insulating plate |
| 33 | Cover | 37 | Level electrode contact plate |
| 34 | Upper part of connector | 38 | Cable clamp |
| 35 | Connection plate | 39 | Cable gland M 19 (PG 11) |

Electrical connection

Connecting the level electrode

Please use the following to connect the level electrode:

- For an NRS 1-51 level switch with a response sensitivity of 5 ppm (10 $\mu\text{S}/\text{cm}$):
Use a shielded, multi-core TC-ER control cable with minimum wire size AWG 18, e.g., OELFLEX CONTROL TM CY 5G1.

Wire the terminal strip as shown in the wiring diagram. **Fig. 21.** Connect the shields to terminal 5 and to the central grounding point (**CGP**) in the control cabinet.

NRG 16-51, NRG 17-51, NRG 19-51 with four-pole connector

1. Undo the screw ③②. **Fig. 20**
2. Remove the upper part ③④ of the connector from the level electrode, leaving the insulating plate ③⑤ on the contact plate ③⑦.
3. Remove the cover ③③.
4. Press the connection plate ③⑤ out of the upper part ③④ of the connector.
The upper part of the connector can be turned in increments of 90°.
5. Detach the cable gland ③⑨ and cable clamp ③⑧ from the upper part ③④ of the connector.
6. Pull the cable through the cable gland ③⑨ and upper part ③④ of the connector and insert the terminals of the connection plate ③⑤ as shown in the wiring diagram.
7. Press the connection plate ③⑤ into the upper part of the connector, and correctly align the cable.
8. Secure the cable with the cable clamp ③⑧ and cable gland ③⑨ .
9. Put on the cover ③③ and insert the screw ③②.
10. Position the upper part of the connector on the level electrode and secure with the screw ③②.

NRG 16-51F, NRG 17-51F, NRG 19-51F with aluminum terminal box

1. Undo the screws ⑫ and take off the cover ⑭ of the terminal box. **Figs. 15, 16**
2. Undo the cable gland ⑬. Pull the cable through the cable entry.
3. Detach the terminal strip ⑮ from the circuit board.
4. Wire the terminal strip as shown in the wiring diagram.
5. Fit the terminal strip.
6. Tighten the cable gland to seal the cable entry.
7. Fit the cover ⑭ of the terminal box and securely tighten the screws ⑫.

Tools

- Phillips screwdriver size PH1
- Flat blade screwdriver size 3/32 in (2.4 mm))
- Open-ended wrench size 19

Electrical connection

Wiring diagram

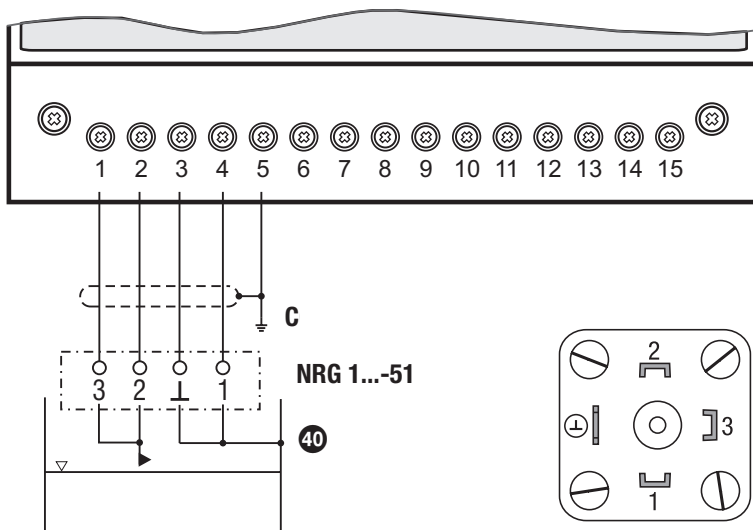

Fig. 21

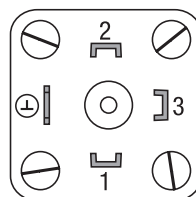

Fig. 22 Connecting the level electrode with four-pole connector

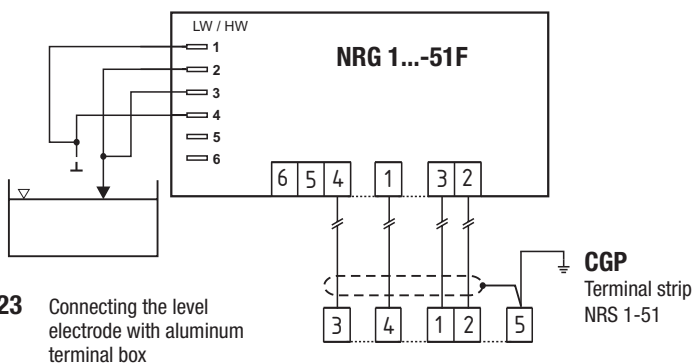

Fig. 23 Connecting the level electrode with aluminum terminal box

Key

④ Level electrode NRG 1...-51

CGP Central grounding point in control cabinet

Bringing into service, fault indications and troubleshooting

You can find information on bringing into service, faults and troubleshooting in the Installation & Operating Manual of the NRS 1-51 level switch.

Taking out of service

DANGER



Danger to life! Escaped hot steam can cause scalding.

Hot steam or hot water can escape suddenly if the level electrode is unscrewed under pressure.

- Reduce the boiler pressure to 0 psi (0 bar) and check the pressure before unscrewing the level electrode.
- Only remove the level electrode at **0 psi (0 bar) boiler pressure**.

WARNING



The hot level electrode can cause severe burns.



The level electrode gets very hot during operation.

- Always let the level electrode cool down before performing installation and maintenance work.
- Only remove level electrodes that have cooled down.



Proceed as follows:

1. Reduce the boiler pressure to 0 psi (0 bar).
2. Allow the level electrode to cool to room temperature.
3. Switch off the supply voltage.
4. Pull out the connector.
5. Then remove the level electrode.

Removing the NRG 1..-51 level electrode

1. Undo the screw  **Fig. 20**
2. Detach the upper part  of the connector from the level electrode.
3. To dismantle the equipment, unscrew the electrode thread  **Fig. 12**, when it has cooled down and is no longer under pressure.

Removing the NRG 1..-51F level electrode

1. Undo the screws  of the terminal box and take off the cover  **Figs. 15, 16**
2. Disconnect the wires from the terminal strip and pull the cables out of the cable gland.
3. To dismantle the equipment, unscrew the electrode thread  **Fig. 12**, when it has cooled down and is no longer under pressure.

Disposal

Dispose of level electrodes in accordance with statutory waste disposal provisions.

Returning decontaminated equipment



If products have come into contact with media that are hazardous to health, they must be drained and decontaminated before being returned to GESTRA AG.

The term 'media' can refer to solid, liquid or gaseous substances or mixtures, as well as radiation.

GESTRA AG can accept returned products only if accompanied by a completed and signed return note and also a completed and signed declaration of decontamination.



The return confirmation and declaration of decontamination must be attached to the outside of the return package, as processing will otherwise be impossible and the products will be returned to the sender at their expense.

Please proceed as follows:

1. Let GESTRA AG know about the return beforehand by e-mail or phone.
2. Wait until you have received the return confirmation from GESTRA.
3. Fill out the return confirmation (including declaration of decontamination) and send it with the products to GESTRA AG.

UL components

The NRG 1...-51 level electrode is registered under XACN.E513189.



You can find our authorized agents around the world at: **www.gestra.com**

GESTRA AG

Münchener Straße 77
28215 Bremen
Germany

Tel. +49 421 3503 0

Fax +49 421 3503 393

e-mail info@de.gestra.com

Web www.gestra.com