

LRGT 16-3n

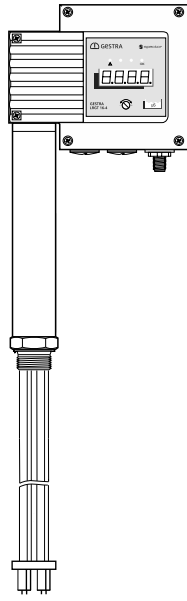

LRGT 16-4n

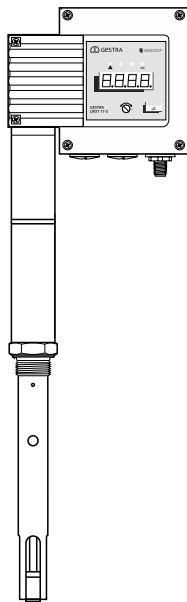

LRGT 17-3n

Conductivity Transmitter

LRGT 16-3n LRGT 16-4n LRGT 17-3n

Description

LRGT 16-3n, LRGT 16-4n and LRGT 17-3n conductivity transmitters can be used as conductivity limiters and continuous blowdown controllers to continually monitor conductivity in steam boiler and hot-water installations. They present a linear profile of conductivity in the parameterized measuring range via a 4 - 20 mA current output.

Function

Transmitter function

The transmitter function is the ability of the electrode to provide a scalable measuring range on the 4-20 mA current output interface, and to make this available to one or more recipients for analysis.

Conductivity transmitters do not have any controlling or limiting functions.

Measuring process of the LRGT 16-3n and LRGT 17-3n

LRGT 16-3 and LRGT 17-3 conductivity transmitters use the conductometric two-electrode measuring process. A measuring current with a suitable frequency for the measuring range is introduced into the fluid. This produces a potential gradient between the electrode and the measuring tube, which is analysed as a measuring voltage.

Measuring process of the LRGT 16-4n

The LRGT 16-4 conductivity transmitter uses the conductometric four-electrode measuring process. It consists of two current and two voltage electrodes. The current electrodes introduce a measuring current with a fixed frequency into the fluid. This gives rise to a potential gradient between these electrodes. This potential gradient is then picked up by the voltage electrodes and analysed as a measuring voltage.

Temperature compensation of readings based on a reference temperature (25 °C)

The electrical conductivity changes as a function of the temperature. In order to base the readings on a reference temperature, an integrated resistance thermometer measures the temperature of the fluid. The electrical conductivity is calculated from the measuring current and measuring voltage, and then based on the reference temperature of 25 °C through temperature compensation.

Compensation process

Based on a set temperature coefficient, the conductivity reading is corrected to form a linear characteristic. The coefficient (default 2.1% per °C) is normally used for steam generating units with a constant pressure.

Automatic self-test

An automatic self-test periodically monitors the safety and function of the conductivity transmitters and measured value acquisition. Faults in the electrical connection or electronic measuring equipment trigger an error message on the display, and the current output is set to 0 mA.

Behaviour in the event of malfunctions

The error state or malfunction is shown on the display by an error code, e.g. E.005.

Every time there is a fault, 0 mA is output via the current output.

Technical data

Model and mechanical connection

- LRGT 16-3n, LRGT 16-4n, LRGT 17-3n:
Thread G1 A, EN ISO 228-1

Nominal pressure rating, admissible service pressure and temperature

- LRGT 16-3n: PN 40 32 bar (g) at 238 °C
- LRGT 16-4n: PN 40 32 bar (g) at 238 °C
- LRGT 17-3n: PN 63 60 bar (g) at 275 °C

Materials

- Terminal box: 3.2581 G AISI12, powder-coated
- Cover tube: 1.4301 X5 CrNi 18-10
- Measuring electrodes: 1.4571 X6CrNiMoTi17-12-2
- Electrode insulation: PTFE
- Screw-in body:
 - ◆ Measuring tube/screw of LRGT 16-3n and LRGT 17-3n: 1.4571, X6CrNiMoTi17-12-2
 - ◆ Spacer discs of LRGT 16-3n and LRGT 16-4n, LRGT 17-3n: PEEK

Available electrode lengths (do not shorten)

- LRGT 16-3n, LRGT 17-3n:
200, 300, 400, 500, 600, 800, 1000 (mm)
- LRGT 16-4n:
180, 300, 380, 500, 600, 800, 1000 (mm)

Temperature sensor

- Resistance thermometer: Pt 1000
- Measuring range for fluid temperature: 0 to 280 °C

Conductivity range at 25 °C

- LRGT 16-3n, LRGT 17-3n:
0.5 µS/cm to 6000 µS/cm, 0.25 - 3000 ppm *
◆ Preferred measuring range up to 1000 µS/cm
 - LRGT 16-4n:
50 µS/cm to 10,000 µS/cm, 25 - 5000 ppm *
◆ Preferred measuring range from 500 µS/cm
- * Conversion µS/cm in ppm (parts per million):
1 µS/cm = 0.5 ppm

Measuring cycle

- for 1 second

Temperature compensation

- The temperature compensation process is linear and set via parameter tC.

Supply voltage

- 24 V DC +/- 20 %

Power consumption

- Max. 7 W

Current input

- Max. 0.35 A

Conductivity Transmitter

LRGT 16-3n

LRGT 16-4n

LRGT 17-3n

Internal fuse

- T2A (slow blow)

Safety cutout at excessive ambient temperature

- The cutout takes place at an excessive ambient temperature of $T_{amb.} = 75\text{ °C}$

Electrode voltage

- < 500 mV (RMS) at no load

Analogue output

- 1 x actual value output 4-20 mA
- Maximum output load 500 Ω
- M12 connector, 5-pole, A-coded

Indicators and controls

- 1 x 4-digit green 7-segment display for showing readings and status information
- 1 x red LED for indicating an error state
- 3 x green LED for indicating the unit $\mu\text{S/cm}$ / ppm and OK status
- 1 x rotary knob IP65 with button for menu navigation and test function

Protection class

- III Safety Extra Low Voltage (SELV)

IP rating to EN 60529

- IP 65

Admissible ambient conditions

- Service temperature: 0 °C - 70 °C
- Storage temperature: -40 °C - 80 °C
- Transport temperature: -40 °C - 80 °C
- Air humidity: 10 % - 95 % (non-condensing)

Weight

- LRGT 16-3n, LRGT 16-4n, LRGT 17-3n: Approx. 2.1 kg

Directives and standards

You can find details on the conformity of the equipment and the applicable standards and directives in our Declaration of Conformity and the relevant certificates or approvals.

Please note our general terms of business.

Important notes

Installation

■ LRGT 16-3n, LRGT 17-3n

Provide spacing of approx. 30 mm between the lower end of the measuring tube and the boiler wall, the smoke tubes, any other metallic fittings, and the low water level (LW).

■ LRGT 16-4n

Provide spacing of approx. 60 mm between the lower end of the measuring electrodes and the boiler wall, the smoke tubes, any other metallic fittings, and the low water level (LW).

- Do **not shorten** the measuring electrode or measuring tube.

Electrical connection

Use a shielded, multi-core control cable with a minimum conductor size of 0.5 mm², e.g. LiYCY 4 x 0.5 mm².

Pre-wired control cables (with plug and coupling) are available as accessories in various lengths.

The LRGT 16-3n, LRGT 16-4n and LRGT 17-3n conductivity transmitters are supplied with 24 V DC.

A safety power supply unit that delivers a Safety Extra Low Voltage (SELV) and is isolated from connected loads must be used to supply the equipment with 24 V DC.

Connecting the actual value output (4-20 mA)

Please note the maximum output load of 500 Ω .

Maximum cable length = 100 m.

How to order and specify:

GESTRA conductivity transmitter LRGT 16-3n

PN 40, connection G1

2-electrode measuring system

Measuring range: 0.5 to 6000 $\mu\text{S/cm}$

Actual value output: 4 – 20 mA

Electrode measuring and installed length.....mm*

GESTRA conductivity transmitter LRGT 17-3n

PN 63, connection G1

2-electrode measuring system

Measuring range: 0.5 to 6000 $\mu\text{S/cm}$

Actual value output: 4 – 20 mA

Electrode measuring and installed length.....mm*

GESTRA conductivity transmitter LRGT 16-4n

PN 40, connection G1

4-electrode measuring system

Measuring range: 50 to 10,000 $\mu\text{S/cm}$

Actual value output: 4 – 20 mA

Electrode measuring and installed length.....mm*

* see Fig. 1

Type:

Stock code:

- LRGT 16-3n 38525.. xx
- LRGT 16-4n 38530.. xx
- LRGT 17-3n 38535.. xx

Electrode length L (mm)	xx			
180	43	⊗	⊗	⊗
200	43			
300	44			
380	45	⊗	⊗	⊗
400	45			
500	46			
600	47			
800	48			
1000	50			
Electrode length is not available =		⊗		

Fig. 1

Additional modules:

- Conductivity controller: LRR 1-51 or LRR 1-53 with URB 50
- Power supply unit: SITOP PSU100C 24 V/0.6 A
- M12 socket: SACC-M12FS-5PL SH

Dimensions (LRGT 16-3n is the example here)

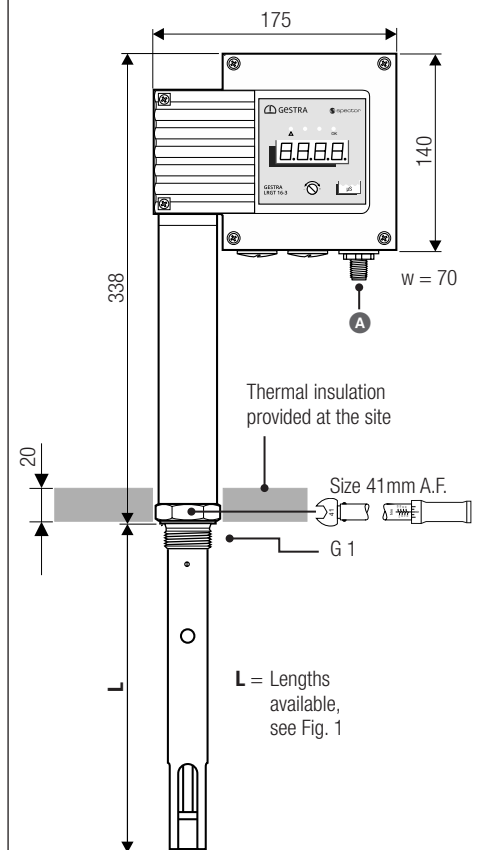

Fig. 2

* The above dimensions also apply to the LRG 16-61 and LRG 17-60, despite their different shapes, see page 1.

Connections

- A M12 connector, 5-pole, A-coded

GESTRA AG

Münchener Straße 77, 28215 Bremen, Germany
Tel. +49 421 3503-0, Fax +49 421 3503-393
e-mail info@de.gestra.com, website www.gestra.com

