

Steam Dryer/Steam Purifier

TD

PN 16, PN 40

DN 15 - 250

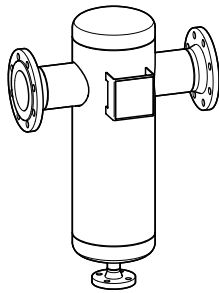

DN 15 - 175

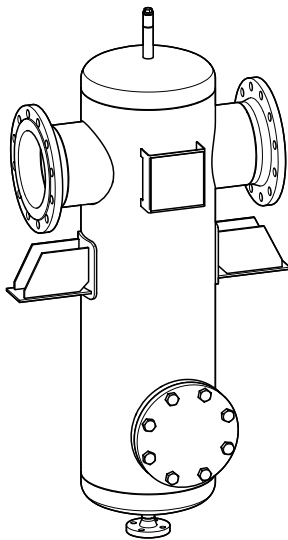

DN 200 - 250

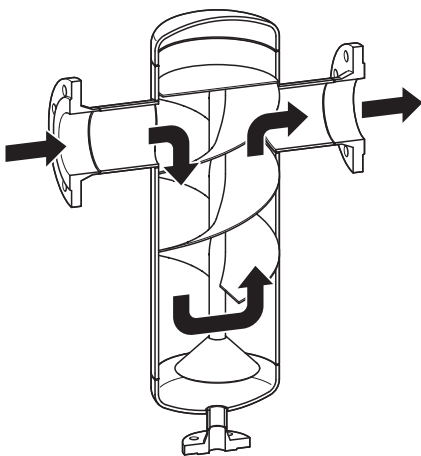

Description

The TD steam dryer/steam purifier is installed in steam systems.

The equipment is used to separate water, suspended liquids and dirt from steam. The equipment may only be used within the admissible pressure and temperature limits, with due consideration of chemical and corrosive influences. Improper use also includes using equipment made of materials that are unsuitable for the fluid used.

Function

The equipment can function as a steam dryer and a steam purifier, either at the same time or individually.

It separates liquids, mist or impurities from the flow of steam with little loss of pressure.

The humid and impure steam flows through the guide helix in a downward spiral. When it is above the sump cover plate, the flow of steam is reversed 180 degrees. The resulting centrifugal forces, impact and swirling effects separate heavier particles such as dirt and liquid from the steam. These heavy particles are then conveyed into the collecting chamber. The abrupt reversal of the flow of steam from one side of the helix to the other prevents the unwanted re-entrainment of the particles after separation.

- The equipment ensures a trouble-free work process and a long service life for heat exchangers and steam consumers.
- The equipment can achieve degrees of saturation of up to 98-99%.

Materials

PN	Material		
	Flange	Pipes	Ends
16	1.0460 (P250GH)	1.0345 (P235GH+N)	1.0425 (P265GH)
16	1.4571 (X6CrNiMoTi17-12-2)		
40	1.0460 (P250GH)	1.0345 (P235GH+N)	1.0425 (P265GH)

Surface treatment

Carbon steel: Inside: Blank
Outside: Primer

Stainless steel: Pickled and passivated

End connections

- Flange PN 16, B1 (EN 1092-1)
- Flange PN 40, B1 (EN 1092-1)
- Flange CLASS 150, RF (ASME B 16.5)
- Flange CLASS 300, RF (ASME B 16.5)
- Screwed socket (DIN 10241)

Optional extras

- Pipe bend for a vertical inlet/horizontal outlet
- Pipe bend for a horizontal inlet/vertical outlet
- UNA

Pressure & temperature ratings

Flange	PN	Material	Max. admissible pressure [bar]	Max. admissible temperature [° C]
TD	16	Steel	13.3	200
TD	40	Steel	30.4	250
TD	16	Stainless steel	14.9	200

Admissible minimum temperature: -10 °C

Equipment selection

Equipment is selected based on the operating data, i.e. the steam mass flowrate and the steam pressure.

Nominal size

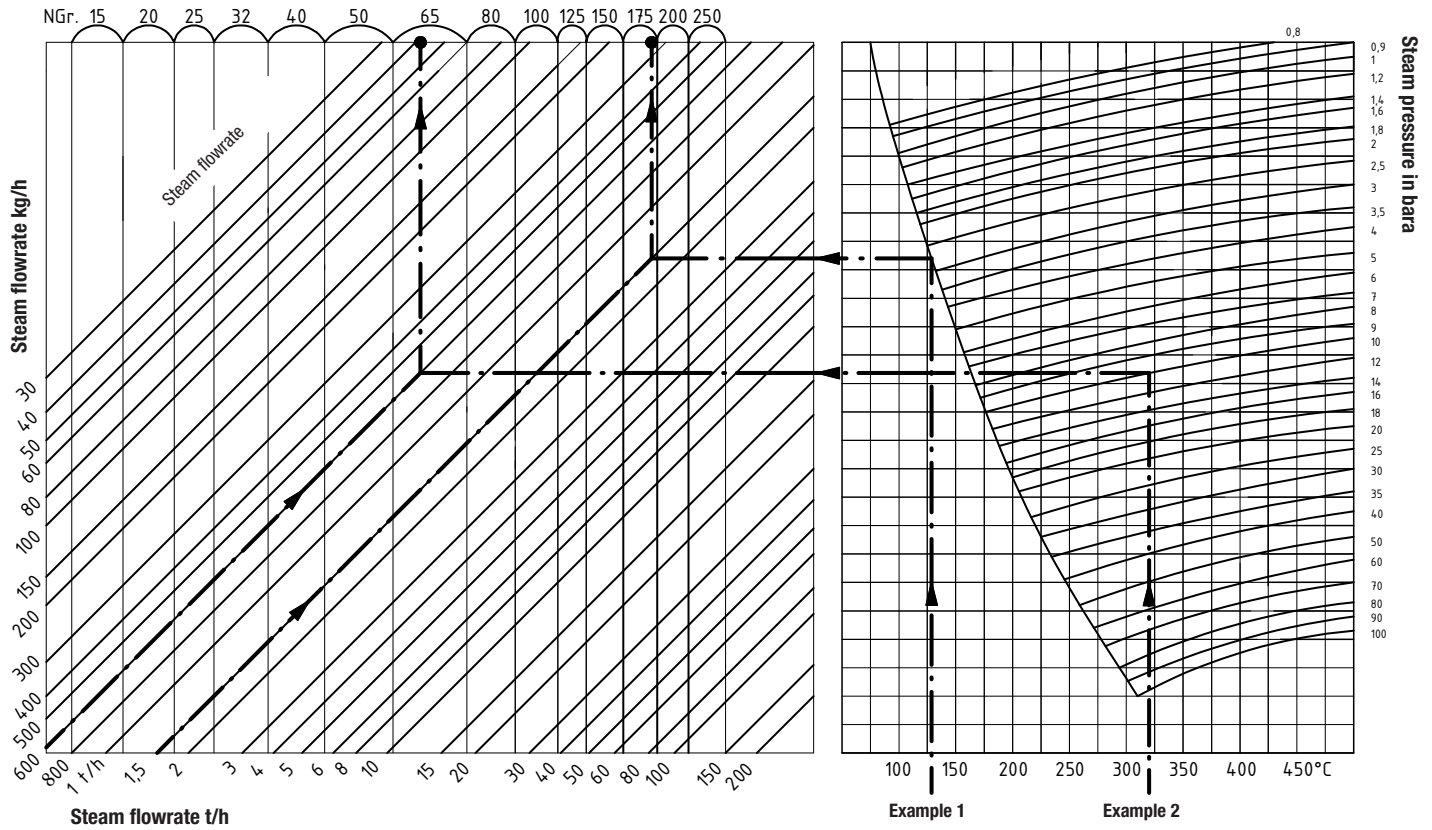

❶ Saturated steam 129.3°C, 2.7 bar, steam flowrate 1.5 t/h

❷ Superheated steam 320°C, 10 bar, steam flowrate 600 kg/h

Overview of TD equipment

Nominal sizes 15 to 175

Nominal size 200 upwards

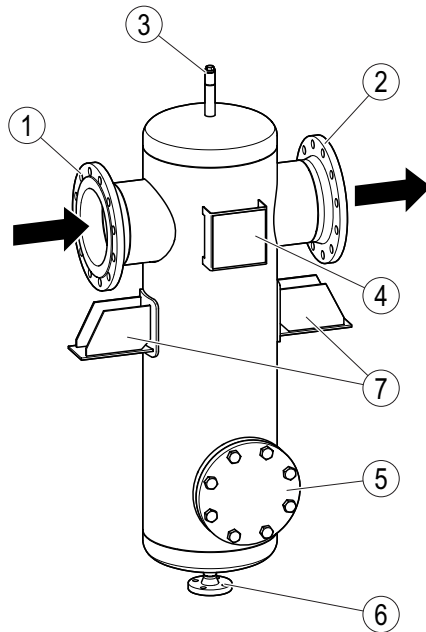
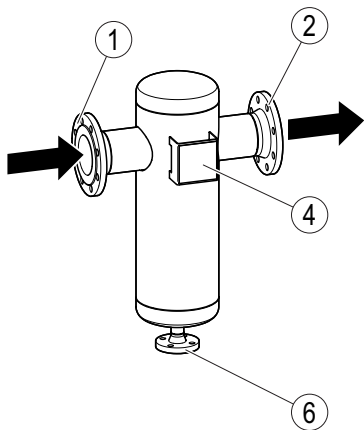

No.	Designation
1	Connection for steam inlet
2	Connection for steam outlet
3	Vent (only needed for work by the manufacturer)
4	Name plate
5	Inspection hole
6	Connection for condensate outlet
7	Lugs (nominal size 200 upwards)

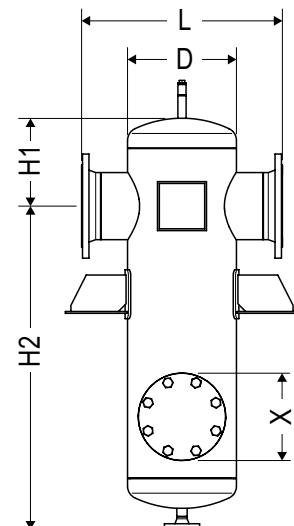

Dimensions and weights

Nominal size

The nominal size depends on the dimensions of the guide chamber which, based on operating conditions, ensures separation of optimum efficiency.

Dimensions and weights

TD, PN 16 and PN 40, steel (dimensional tolerances to DIN 28005-1)

Nominal size	Nominal diameter Steam inlet/outlet DN	Condensate outlet DN	Inspection hole DN	Dimensions				Volume V l	Weight PN 16 m kg	Weight PN 40 m kg	Steel PN 16 Classification fluid group 2		Steel PN 40 Classification fluid group 2	
				D mm	L mm	H2 mm	H1 mm				Module	Category	Module	Category
15	15	15		60	210	310	80	0.6	5.4	5.4	Item 4(3)		Item 4(3)	
20	15 20	15 15		60	220	305	85	0.7	5.4 6.1	5.4 6.1	Item 4(3)		Item 4(3)	
25	15 20 25	15 15 15		70	220	385	95	1.4	7.0 7.6 8.1	7.0 7.6 8.1	Item 4(3)		Item 4(3)	
32	20 25 32	15 15 15		70	220	375	105	1.5	7.6 8.1 9.4	7.6 8.1 9.4	Item 4(3)		Item 4(3)	
40	25 32 40	15 15 15		115	270	370	120	3.5	11.0 12.1 12.6	11.0 12.1 12.6	Item 4(3)		A	I
50	32 40 50	15 15 15		115	270	360	130	3.7	12.1 12.5 13.5	12.1 12.5 14.0	Item 4(3)		A	I
65	40 50 65	15 15 15		170	320	460	150	10.6	21.3 22.1 23.4	21.3 22.7 24.4	A	I	A2	II
80	50 65 80	15 15 15		200	360	500	160	14.7	28.0 29.1 30.7	30.3 31.9 33.9	A	I	A2	II
100	65 80 100	20 20 20		220	410	570	190	22.9	37.4 39.1 40.1	43.1 45.2 48.3	A2	II	A2	II
125	80 100 125	20 20 20		250	440	655	215	34	47.3 48.3 52.0	64	A2	II	B+F, or G	IV
150	100 125 150	25 25 25		270	500	740	230	49	59.1 62.8 65.6	87	A2	II	B+F, or G	IV
175	125 150	25 25		320	560	870	240	76	83	113	B+F, or G	III	B+F, or G	IV
200	150 200	25 25	150 150	350	650	1055	285	119	151	216	B+F, or G	III	B+F, or G	IV
250	150 200 250	25 25 25	150 150 150	400	720	1170	330	178	201	316	B+F, or G	III	B+F, or G	IV

TD, PN 16, stainless steel 1.4571 (dimensional tolerances to DIN 28005-1)

Nominal size	Nominal diameter Steam inlet/outlet DN	Condensate outlet DN	Inspection hole DN	Dimensions				Volume V l	Weight PN 16 m kg	Stainless steel PN 16 Classification fluid group 2	
				D mm	L mm	H2 mm	H1 mm			Module	Category
15	15	15		60	210	310	80	0.6	5.0	Item 4(3)	
20	15 20	15 15		60	220	305	85	0.7	5.0 6.0	Item 4(3)	
25	15 20 25	15 15 15		70	220	385	95	1.4	6.3 7.0 7.4	Item 4(3)	
32	20 25 32	15 15 15		70	220	375	105	1.5	7.0 8.0 9.0	Item 4(3)	
40	25 32 40	15 15 15		115	270	370	120	3.5	10.0 11.0 11.9	Item 4(3)	
50	32 40 50	15 15 15		115	270	360	130	3.7	11.4 11.8 13.2	Item 4(3)	
65	40 50 65	15 15 15		170	320	460	150	10.6	19.0 19.2 20.5	A	I
80	50 65 80	15 15 15		200	360	500	160	14.7	23.0 25.0 25.6	A	I
100	65 80 100	20 20 20		220	410	570	190	22.9	33.0 34.0 35.0	A2	II
125	80 100 125	20 20 20		250	440	655	215	34	41.0 42.0 46.0	A2	II
150	100 125 150	25 25 25		270	500	740	230	49	52.0 55.0 52.0	A2	II
175	125 150	25 25		320	560	870	240	76	On request	B+F, or G	III
200	150 200	25 25	150 150	350	650	1055	285	119	On request	B+F, or G	III
250	150 200 250	25 25 25	150 150 150	400	720	1170	330	178	On request	B+F, or G	III

Steam Dryer/Steam Purifier

TD

PN 16, PN 40

DN 15 - 250

Application examples

- Downstream from steam boilers and high-speed steam generating units
- Between the boiler and the superheater
- In steam pipes upstream from the main manifold
- In district heating pipes and wet steam pipes
- Upstream from turbines, steam motors and steam-operated tools
- For direct exposure to steam
- For spray mist in air conditioning systems.

Drainage of separated liquid

To drain liquid, a GESTRA ball-float steam trap should be installed below the equipment, e.g. UNA14v, UNA16v, UNA16Av, UNA45v, UNA46v or UNA46Av.

(More detailed descriptions can be found in separate data sheets.)

Steam traps are selected on the basis of the operating data or the customer's wishes.

Design in accordance with the AD 2000 Code of Practice

- Without alternating stress to S1 and S2
- Without additional load to S3/6

Manufactured and tested in accordance with the Pressure Equipment Directive PED 2014/68/EU.

Special designs

Contrary to the temperature and pressure ratings specified in this data sheet, our steam dryer is available in special designs (e.g. TD-LKD).

Application of European Directives

Pressure Equipment Directive

The equipment conforms to this directive and can be used for the following fluids:

- Group 2 fluids

ATEX Directive

The equipment does not have its own potential ignition source and is therefore not subject to this directive.

Static electricity: Once installed, static electricity may arise between the equipment and the connected system.

If used in potentially explosive atmospheres, the plant manufacturer or owner is responsible for discharging or preventing possible static charge.

If it is possible for fluid to escape, e.g. through actuating mechanisms or leaks in threaded joints, the plant manufacturer or owner must take this into consideration when dividing the area into zones.

Please note our general terms of business.

Installation examples

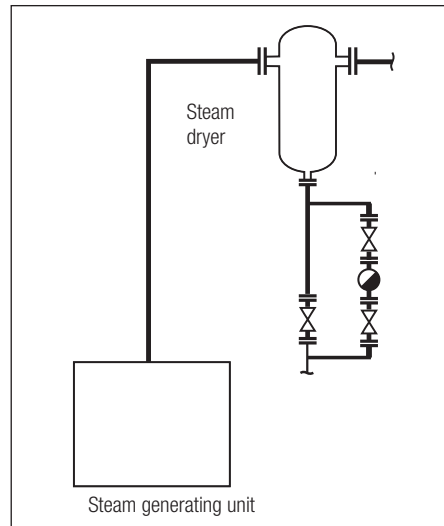

Steam dryer downstream from a steam generating unit with stop valves

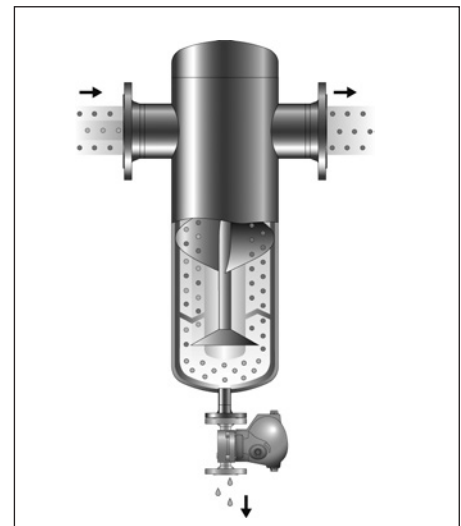

Installation examples with steam trap

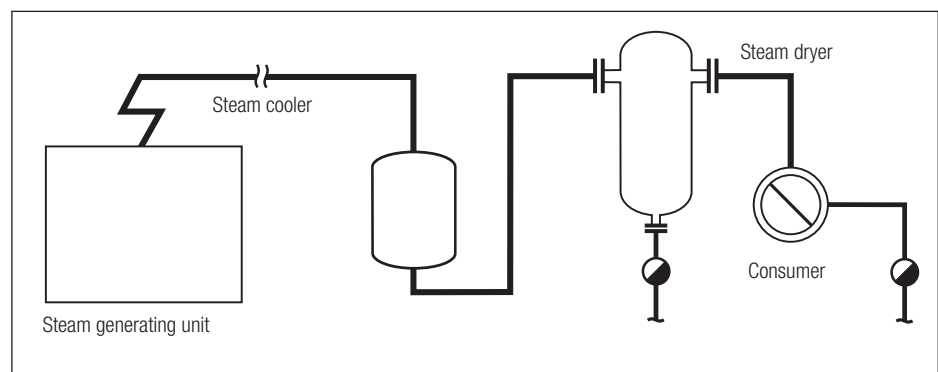

Steam dryer upstream from a heat exchanger

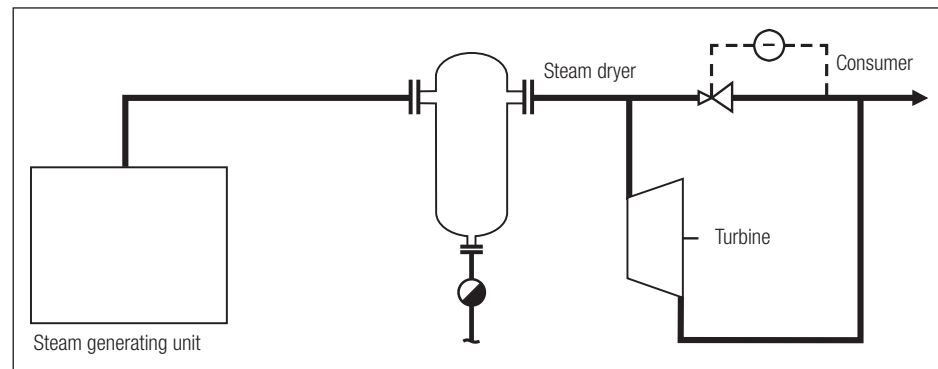

Steam dryer upstream from a turbine

GESTRA AG

Münchener Straße 77, 28215 Bremen, Germany
Tel. +49 421 3503-0, Fax +49 421 3503-393
e-mail info@de.gestra.com, website www.gestra.com

