

CB 26

End Connections

- Flange EN 1092-1 B1 PN 40
- Flange ASME B 16.5 Class 150 RF, 300 RF
- Screwed sockets G: ISO 228-1
- Screwed sockets NPT: ASME B 16.11
- Socket-weld ends DIN EN 12760
- Socket-weld ends ASME B 16.11 Class 3000
- Butt-weld ends via transition pieces to EN 12627 welded joint geometry ISO 9692-1 code number 1.3 (30° chamfer)
- Butt-weld ends via transition pieces ASME B 16.25 ASME B 36.10

Fluids

The equipment is designed for the following fluids (in accordance with the EU Pressure Equipment Directive or Pressure Equipment (Safety) Regulations in the UK):

CB 24S:

- Fluids of group 2

CB 26 and CB 26A:

- Fluids of group 1
- Fluids of group 2

Due consideration must be given to chemical and corrosive influences.

Application in potentially explosive areas

The equipment does not have its own potential source of ignition (as per ATEX Directive). Please pay attention to the following information:

When installed, static electricity may arise between the equipment and the connected system.

When used in potentially explosive atmospheres, the plant manufacturer or plant operator is responsible for discharging or preventing possible static charge.

If it is possible for medium to escape, e.g. through actuating mechanisms or leaks in threaded joints, the plant manufacturer or plant operator must take this into consideration when dividing the area into zones.

Swing Check Valve

CB 24S for Flanges PN 6/10/16, DN 50 to 300

CB 26 for Flanges PN 6/10/16/25/40, DN 50 to 300

CB 26A for Flanges PN 6/10/16/25/40, DN 50 to 300

Equipment specification

The equipment prevents the back flow in liquid and gas lines.

The equipment is used for the following applications:

CB 24S for sea water and other saline fluids for which the equipment material is suitable.

CB 26 for industrial applications for fluids such as gases, liquids, steam and other non-corrosive media.

CB 26A for industrial applications for fluids such as gases, liquids, steam and corrosive/aggressive fluids for which the equipment material is suitable.

Description

CB 24S, CB 26 and CB 26A are wafer-type swing check valves with short overall length to EN 558-1, series 96. The low weight of the equipment is beneficial for transportation, storage and installation.

Equipment type CB 24S is designed to be sandwiched between flanges according to the following standards:

EN 1092 PN 6/10/16 ASME B 16.1 Class 125 FF and ASME B 16.5 Class 150 RF

The equipment has a soft seat made from NBR as standard.

Equipment types CB26 and CB26A are designed to be sandwiched between flanges according to the following standards:

EN 1092 PN 6/10/16/25/40 ASME B 16.1 Class 125 FF and ASME B 16.5 Class 150/300 RF

The equipment has a soft seat made from EPDM as standard.

The equipment can be installed in horizontal or vertical pipes. If the equipment is mounted in a vertical pipe the flow must always be upwards.

Function

The one-piece flap opens and closes as a function of the flow direction of the fluid in the pipe, thereby ensuring unidirectional flow. The equipment features non-slam spring-assisted closing.

Pressure & temperature ratings

Limiting conditions for CB 24S, DN 50 – 300, acc. to EN1092-1 (2013)

T (temperature) [°C]	20	90 ¹⁾	120 ¹⁾	200 ¹⁾	250 ¹⁾
p (pressure) [bar]	16.0	16.0	16.0	16.0	15.6
Pressure rating	PN 16				
Min. temperature	– 200 °C				

¹⁾ If temperatures exceed 90 °C use equipment without springs.

The specified minimum temperature is the lowest admissible service temperature at nominal pressure.

Limiting conditions for CB 26, acc. to DIN EN 12516-1 (2015)

T (temperature) [°C]	20	100	200	300 ¹⁾	350 ¹⁾	400 ¹⁾	420 ¹⁾
DN 50 – 150							
p (pressure) [bar]	40.0	37.1	33.3	27.6	25.9	23.8	17.1
DN 200 – 300							
p (pressure) [bar]	40.0	37.1	33.3	27.6	–	–	–
Pressure rating	PN 40						
Min. temperature	– 10 °C						

¹⁾ If temperatures exceed 300 °C use equipment without springs.

The specified minimum temperature is the lowest admissible service temperature at nominal pressure.

Limiting conditions for CB 26A, DN 50 – 300, acc. to 12516-1 (2014)

T (temperature) [°C]	20	100	150	200	250	300 ¹⁾	350 ¹⁾	400 ¹⁾	450 ¹⁾
p (pressure) [bar]	40.0	40.0	38.6	35.8	34.2	32.5	30.8	29.1	28.0
Pressure rating	PN 40								
Min. temperature	– 10 °C								

¹⁾ If temperatures exceed 300 °C use equipment without springs.

The specified minimum temperature is the lowest admissible service temperature at nominal pressure.

If the operating temperatures exceed 300 °C intercrystalline corrosion may occur. Do not subject the equipment to operating temperatures higher than 300 °C unless intercrystalline corrosion can be ruled out.

Limiting conditions for soft seats

Type	Temperature range [°C]	Leak rate
EPDM	–40 to +150	EN 12266-1, P12, leak rate A
FPM	–25 to +200	EN 12266-1, P12, leak rate A
PTFE	–25 to +200	EN 12266-1, P12, leak rate G
NBR	–30 to +110	EN 12266-1, P12, leak rate A

To guarantee tight shut-off a certain differential pressure to close is required.

Check the chemical suitability of the seat material. For more information go to www.gestra.com, click on "Service & Support" and then on "Chemical resistance of valves".

Materials

Materials CB 24S

Component part	EN number	Short designation
Body DN 50 – 80	CC483K-GC	CuSn12-C-GC
Body DN 100	CC483K-GS	CuSn12-C-GS
Body DN 125 – 300	CC332G-GS	CuAl10Ni3Fe2-C-GS
Flap	CC332G-GS	CuAl10Ni3Fe2-C-GS
Springs to close	CW452K	CuSn6F90
Shaft and support pins	CW453K	CuSn8F38
Sleeves ¹⁾	CW453K	CuSn8F38

¹⁾ only for DN 200 - 300

Materials CB 26

Component part	EN number	Short designation
Body DN 50 – 200	1.0460	P 250 GH
Body DN 250 – 300	1.0460	P 250 GH
Flap DN 50 – 150	1.4581	G-X5CrNiMoNb19-11-2
Flap DN 200 – 300	5.3103	EN-GJS-400-18-U-LT
Bow springs	1.4571	X6CrNiMoTi17-12-2
Shaft and support pins		
Sleeves ¹⁾		

¹⁾ only for DN 200 - 300

Materials CB 26A

Component part	EN number	Short designation
Body DN 50 – 250	1.4571	X6CrNiMoTi17-12-2
Body DN 300	1.4581	G-X5CrNiMoNb19-11-2
Flap	1.4581	G-X5CrNiMoNb19-11-2
Bow springs	1.4571	X6CrNiMoTi17-12-2
Shaft and support pins		
Sleeves ¹⁾		

¹⁾ only for DN 200 - 300

Dimensions and weights

CB 24S

DN	Dimensions [mm]				Weight [kg]
	L ¹⁾	D	a	d ²⁾	
50	17	98	40	55	0.9
65	20	118	50	69	1.4
80	24	132	58	80	2.0
100	27	154	72	90	3.1
125	32	184	88	118	5.2
150	32	209	112	132	6.7
200	42	264	150	190	13.7
250	47	319	182	228	22.9
300	52	375	216	275	32.8

¹⁾ Overall length according to EN 558-1, series 96

²⁾ Min. admissible flange bore (inside pipe diameter)

CB 26 and CB 26A

DN	Dimensions [mm]				Weight [kg]
	L ¹⁾	D	a	d ²⁾	
50	17	98	40	55	0.9
65	20	118	50	69	1.4
80	24	132	58	80	2.0
100	27	154	72	90	3.1
125	32	184	88	118	5.3
150	32	209	112	132	6.9
200	42	264	150	190	14.1
250	47	319	182	228	23.6
300	52	375	216	275	33.8

¹⁾ Overall length according to EN 558-1, series 96

²⁾ Min. admissible flange bore (inside pipe diameter)

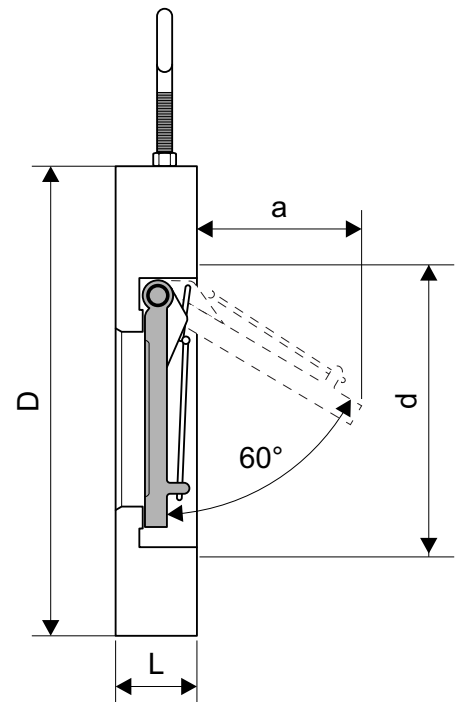

Swing Check Valve CB 24S, CB 26, CB 26A

Specification Text

GESTRA Swing Check Valves CB

Wafer-type swing check valve with short overall length to EN 558-1, series 96 Suitable for fitting between pipe flanges to EN and ASME. Full opening angle 60°, metal-to-metal or soft seat (EPDM, FPM, NBR or PTFE), with metal hinge and two springs.

Type:

Nominal size DN:

Pressure rating PN/Class:

End connection:

The valves should not be used on compressors or where pulsating flow exists.

For these applications please consult us and specify the application in question and indicate the operating data when ordering.

When ordering please state:

Fluid, flowrate, service pressure and temperature.

Standard designation of pipe flanges.

Valve seats for CB 26 and CB 26A

Metal-to-metal, EPDM, FPM or PTFE

Valve seats for CB 24S

Metal-to-metal, EPDM, FPM, NBR

Inspection & Certification

Documentation regarding material tests and in-house examination with test report to EN 10204-2.2 or inspection certificate EN 10204-3.1 available at extra cost. Please state the inspection and certification requirements when inquiring or ordering. After supply of the equipment certification cannot be established. Charges and extent of the above mentioned certificates as well as the different tests confirmed therein are listed in our price list "Test and Inspection Charges for Standard Equipment". For other test certificates please consult us.

Directives and standards

You can find details on the conformity of the equipment and the applicable standards and directives in our Declaration of Conformity and the relevant certificates or approvals.

Supply in accordance with our general terms of business.

Pressure Drop Chart

The curves given in the chart are valid for water at 20°C. For other fluids it is necessary to calculate an equivalent water volume flowrate \dot{V}_w and use this in the chart.

The pressure drop values indicated in the chart are applicable to spring-assisted valves with horizontal flow and to valves without spring mounted in vertical pipes with upward flow.

$$\dot{V}_w = \dot{V} \cdot \sqrt{\frac{\rho}{1000}}$$

\dot{V}_w = Equivalent water volume flowrate in [l/s] or [m³/h]

ρ = Density of the fluid (operating condition) in [kg/m³]

\dot{V} = Volume flowrate of the fluid (operating condition) in [l/s] or [m³/h]

Opening pressures [mbar]

DN	Direction of flow		
	Without spring ↑	With spring	
		↑	→
50 – 80	5	12	7
100-150	11	18	7
200-300	18	25	7

Differential pressures at zero volume flow.

■ Required minimum volume flowrate \dot{V}_w for equipment fitted with standard spring and mounted in horizontal pipes.

■ Required minimum volume flowrate \dot{V}_w for equipment fitted without spring and mounted in vertical pipes with upward flow.

Min. volume flowrate \dot{V}_w for full opening [m³/h]

DN	Direction of flow		
	Without spring ↑	With spring	
		↑	→
50	4	6	6
65	7	10	12
80	10	20	20
100	18	30	30
125	30	40	48
150	60	70	80
200	90	150	160
250	160	220	260
300	200	300	360

The curves given in the chart are valid for water at 20°C.

If the actual flowrate is below the min. volume flow \dot{V}_w the equipment is partly open (unstable range). Chattering, noises and increased wear may occur.

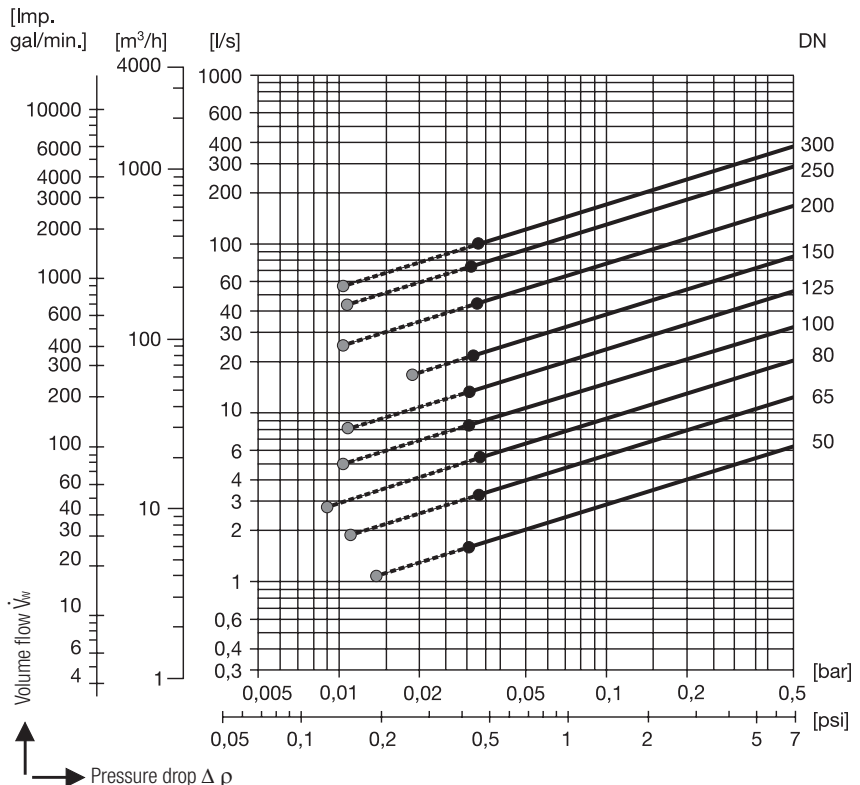

GESTRA AG

Münchener Straße 77, 28215 Bremen, Germany
Telefon +49 421 3503-0, Telefax +49 421 3503-393
E-mail info@de.gestra.com, Web www.gestra.com

