

TRS 5-50

Temperature Switch

TRS 5-50

Description

The temperature switch TRS 5-50 is used in conjunction with temperature sensor TRG 5-6.. as safety temperature limiter or monitor, for instance in steam boilers and (pressurised) hot-water plants. When the max. admissible temperature in the superheater or the inlet line is reached, the safety temperature limiter or monitor switches the heating off.

The temperature switch TRS 5-52 is designed for use in conjunction with temperature sensors TRG 5-63, TRG 5-64, TRG 5-65, TRG 5-66, TRG 5-67 and TRG 5-68.

Function

A platinum resistance thermometer Pt 100 to EN 60751 is used as temperature sensor for the temperature switch TRS 5-50. A three-wire configuration is used for the electrical connection.

The temperature switch processes the temperature-dependent changes in resistance of the temperature sensor and, during normal operation, the seven-segment LED display shows the adjusted switch-off temperature T_{MAX} (°C) and the actual value T (°C).

The switchpoint for MAX temperature can be variably adjusted within the measuring range. Once the MAX temperature is reached both output contacts of the temperature switch open the safety circuit and the seven-segment LED display for T_{MAX} is flashing.

In addition the relay contact for external signalling equipment is closed.

If the system is configured as safety temperature monitor, the temperature switch does not automatically interlock the deactivation of the heating. As soon as the temperature has fallen below the non-adjustable hysteresis, the safety circuit will be closed again.

However, if the system is configured as safety temperature limiter, the temperature switch automatically interlocks the deactivation of the heating. Note that once the temperature has fallen below the non-adjusted hysteresis, the equipment must be reset manually or externally in order to close the safety circuit.

Any error or malfunction that occurs in the temperature sensor, the electrical connection or the temperature switch is indicated by the seven-segment LED display and the output contacts will be opened.

An automatic self-testing routine monitors the safety functions in the temperature switch and the temperature sensor. In the event of a malfunction the safety circuit opens instantaneously and switches the heating off.

Parameter settings can be changed, a MAX temperature alarm can be simulated and the equipment can be reset by operating the rotary button.

For external temperature indication the equipment is optionally available with an actual-value output 4-20 mA.

Functional Safety acc. to IEC 61508

Safety characteristics of the subsystem TRG 5-6.. / TRS 5-50

The equipment combination TRG 5-6.. / TRS 5-50 corresponds to a type B subsystem with Safety Integrity Level (SIL) 3. Type B means that the behaviour under fault conditions of the used components cannot be completely determined. The functional safety of the equipment combination refers to the detection and evaluation of the temperature and, as a consequence, the contact position of the output relays.

The design of the equipment combination TRG 5-6.. / TRS 5-50 corresponds to the architecture 1oo2. This architecture consists of two channels that detect and diagnose faults in each other. If a fault is detected, the equipment combination TRG 5-6.. / TRS 5-50 will go to the safe state, which means that the contacts of both output relays will open the safety circuit. The equipment is suitable for machines and installations up to performance level "e".

Safety characteristics	SIL	Architecture	Life time (a)	Proof Test Interval (a)
General	3	1oo2	20	20
	SFF	PFD _{av}	PFH _{av}	λ _{DU}
Temperature switch TRS 5-50 (alone)	99.6 %	2.69 x 10 ⁻⁵	3.07 x 10 ⁻⁹	2.95 x 10 ⁻⁹ / h
Temperature switch TRS 5-50 in conjunction with one temperature sensor TRG 5-6..	98.2 %	1.71 x 10 ⁻⁴	1.96 x 10 ⁻⁸	1.95 x 10 ⁻⁸ / h

Terms / Abbreviations	Description
Safety Integrity Level SIL	Classification of the Safety Integrity Level acc. to IEC 61508
Life time (a)	Functional safety: Life time of equipment combination in years
Safe Failure Fraction SFF	Percentage of failures without the potential to put the safety-related system into a dangerous state
Probability Failure per Demand (Low Demand) PFD _{av}	Average probability of failure on demand for low demand mode (once a year)
Probability Failure per Hour PFH _{av}	Probability of failure per hour
λ _{DU}	Failure rate for all dangerous undetected failures (per hour) of a channel of a subsystem

Determination of the Safety Integrity Level (SIL) for safety-related systems

Temperature sensor, temperature switch and actuators (auxiliary contactor in safety circuit) are subsystems and together constitute a safety-related system that executes a safety function.

The specification of the safety-related characteristics refers to the temperature sensor and the temperature switch including the output contacts. The actuator (e. g. an auxiliary contactor in the safety circuit) is installation specific and, according to IEC 61508, must be considered separately for the whole safety-related system.

Potentially explosive areas

The equipment must not be used in potentially explosive areas.

Temperature Switch

TRS 5-50

Technical data

Supply voltage

24 VDC +/- 20%, 0.3 A;
100-240 VAC + 10 / - 15%, 47-63 Hz, 0.2 A

Fuse

external 0.5 A (semi-delay)

Power consumption

7 VA

Connection of temperature sensor

1 input for temperature sensor TRG 5-63, TRG 5-64, TRG 5-65, TRG 5-66, TRG 5-67 and TRG 5-68, (platinum resistance thermometer Pt 100 to EN 60751), 3 poles with screen.

Connection for external test & reset

1 volt-free input, 24 VDC, for connecting external reset and test button.

Safety circuit

2 volt-free make contacts,
6 A 250 V AC / 30 V DC $\cos \varphi = 1$
(external slow-blow fuse 2 A)

Provide inductive loads with RC combinations according to manufacturer's specification to ensure interference suppression.

1 analogue output 4-20 mA (0 - 650 °C), max. load 500 ohm, e. g. for actual-value indication (optional)

Signal output

1 volt-free output for instantaneous external signalling, 24 V DC, max. 100 mA (semiconductor output)

Limit range

0 °C up to 600 °C

Switching hysteresis

Switchpoint for MAX temperature -2 °C, fixed setting.

Indicators and adjusters

1 rotary button with integrated pushbutton for setting the MAX temperature and testing and resetting the equipment.
1 pushbutton (hidden) for enabling the setting.
2 seven-segment three-digit LED display for MAX temperature and actual value

Housing

Housing material: base: polycarbonate, black;
front: polycarbonate, grey
Conductor size: 1 x 4.0 mm² solid per wire or 1 x 2.5 mm² per stranded wire with sleeve to DIN 46228 or 2 x 1.4 mm² per stranded wire with sleeve to DIN 46228 terminal strips can be detached separately
Fixing of housing: Mounting clip on supporting rail TH 35, EN 60715

Electrical safety

Pollution degree 2, overvoltage category III to EN 61010-01

Protection

Housing: IP 40 to EN 60529
Terminal strip: IP 20 to EN 60529

Weight

Approx. 0.5 kg

Ambient temperature

when system is switched on: 0 ... 55 °C,
during operation: -10 ... 55 °C

Transport temperature

-20 ... +80 °C (<100 hours), defrosting time of the de-energized equipment before it can be put into operation: 24 hours. 24 hours.

Storage temperature

-20 ... +70 °C, defrosting time of the de-energized equipment before it can be put into operation: 24 hours.

Relative humidity

max. 95%, no moisture condensation

Site altitude

max. 2000 m

Directives and Standards

For more information on the conformity of the equipment as well as applied Directives and Standards please refer to our Declaration of Conformity and associated certificates and/or approvals.

Supply in accordance with our general terms of business.

Dimensions

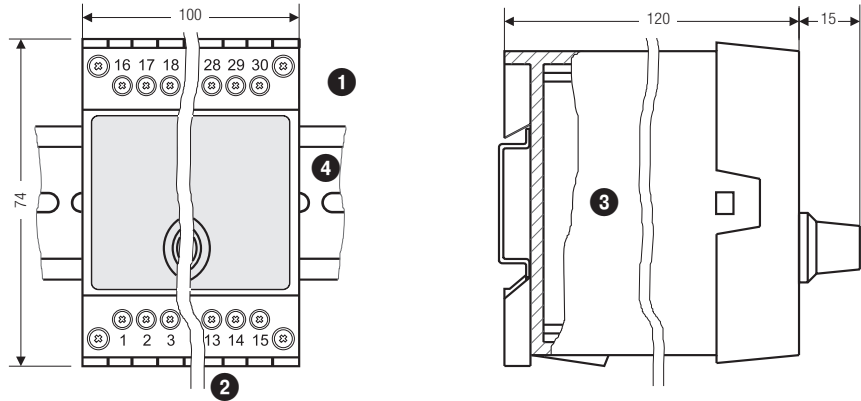

Fig. 1 TRS 5-50

Electrical connection TRS 5-50

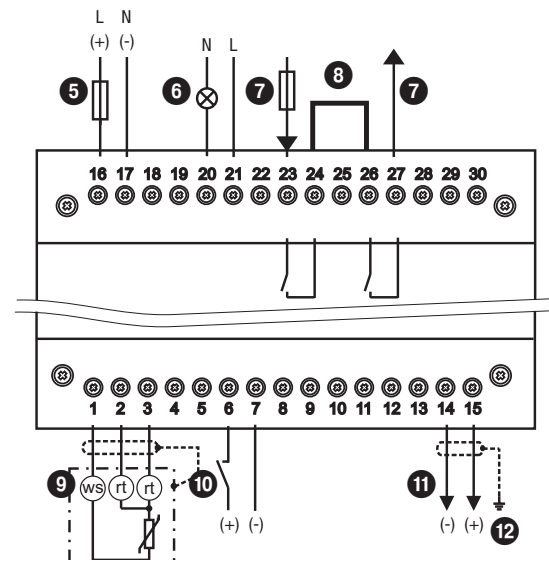

Fig. 2

Key

- 1 Upper terminal strip
- 2 Lower terminal strip
- 3 Housing
- 4 Supporting rail type TH 35, EN 60715
- 5 Connection of supply voltage with fuse 0.5 A (semi-delay) provided on site
- 6 Signal output for external alarm 24 V DC, max. 100 mA (semiconductor output)
- 7 Safety circuit, input and output
- 8 Wire link, provided on site, if equipment is used as safety temperature limiter to EN 12952 / EN 12953
- 9 Temperature sensor TRG 5-6... screen via cable gland
Terminal ws = white Terminal rt = red
- 10 Reset / Test input, 24 VDC
- 11 Actual value output 4 - 20 mA (0 - 650 °C) (option)
- 12 Central earthing point (CEP) in control cabinet

Important Notes

The temperature switch TRS 5-50 is clipped onto the support rail in the control cabinet.

Use a safety power supply unit (SELV) to feed the temperature switch TRS 5-50 with 24 V DC.

To prevent the welding together of contacts provide an external slow-blow fuse T 2 A for the output contacts. When switching off inductive loads, voltage spikes are produced that may impair the operation of control systems. Connected inductive loads must be provided with suppressors such as RC combinations as specified by the manufacturer.

To connect the temperature sensor TRG 5-... use screened multi-core control cable with a min. conductor size 0.5 mm², e. g. LiYCY 4 x 0.5 mm², max. length: 100 m.

The equipment can be tested or reset externally by means of a voltage pulse at the reset/test input. For this purpose connect a 24 V DC voltage source with pushbutton to terminals 6 and 7. For the connection use screened multi-core control cable with a min. conductor size 0.25 mm², e. g. LiYCY 2 x 0.25 mm², max. length: 10 m.

For external temperature indication the equipment is optionally available with an actual-value output 4-20 mA (corresponding to 0 - 650 °C). For the connection use screened multi-core control cable with a min. conductor size 0.5 mm², e. g. LiYCY 2 x 0.5 mm², max. length: 100 m. Please take a max. load of 500 ohm into consideration.

Any device that you want to connect to the reset/test input and the actual value output must be certified to have at least double or reinforced isolation according to EN 50178 or EN 61010-1 or EN 60730-1 or EN 60950 (safe electrical isolation) between the input / output and the live parts of the installation that are not supplied with safety extra-low voltage (SELV).

Make sure that connecting cables between the equipment are segregated and run separately from power cables.

Order & Enquiry Specification

Safety temperature type TRS 5-50

GESTRA SPECTOR module

Safety Integrity Level SIL 3

Output: 2 separate force-guided change-over contacts for safety circuit

Indication: 2 seven-segment LED displays for indication of actual value, limit and alarm

Voltage supply: 24 VDC, 5 VA

Optional extras (please state when ordering):

1 actual value output 4-20 mA

GESTRA AG

Münchener Straße 77, 28215 Bremen, Germany
Telefon +49 421 3503-0, Telefax +49 421 3503-393
E-mail info@de.gestra.com, Web www.gestra.com

