

NRS 2-50

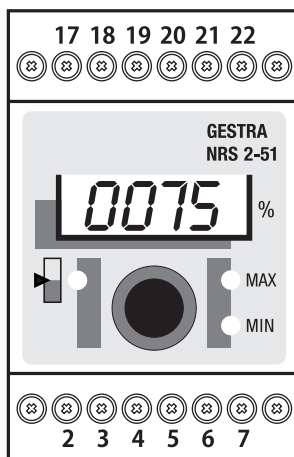

NRS 2-51

## Level Switch

### NRS 2-50, NRS 2-51

#### Description

The level switch NRS 2-50 / NRS 2-51 in conjunction with level electrodes NRG 2... and level transmitters NRG 26... is used as limit switch and water level controller, for instance in steam boilers, (pressurized) hot-water installations as well as condensate and feedwater tanks. The level switch detects and indicates when the preset MIN or MAX water level is reached and in addition switches the feedwater pump on and off (NRS 2-51).

The level switch is designed to be used with level electrodes NRG 21... and NRG 26-21 as well as the level transmitters NRG 26-..

#### Function

The level switch NRS 2-50, NRS 2-51 uses the level-dependent voltage signals emitted by the level electrodes NRG 2... or the level-dependent current signal emitted by the level transmitters NRG 26-..

The level switch NRS 2-50 / NRS 2-51 adjusts the input signal to 0 and 100 % of the boiler measuring range and the switch-points for MIN / MAX water level are correspondingly adjusted within this measuring range. During normal operation the actual value is indicated on the seven-segment LED display.

When the MIN or MAX water level is reached, the MIN or MAX output contact is switched over after the de-energizing delay and the MIN or MAX LED is illuminated.

The level switch NRS 2-51 also works as on-off water level controller (fill or discharge control, switch-selectable). If the lower or upper switchpoint for water level control is reached, the controller output switches over according to the preset function and, consequently, switches the feedwater pump on or off. The amber LED is illuminated when the feedwater pump is switched on by the level switch.

Any faults or malfunctions in the level electrode, the level transmitter, the electrical connection or the settings will be indicated by the seven-segment LED display. In the event of a malfunction a MIN and MAX alarm will be triggered.

If errors occur only in the level switch NRS 2-50 / NRS 2-51, a MIN and MAX alarm is raised and the system is restarted.

Parameter settings can be changed or a MIN/MAX alarm be simulated by operating the rotary button.

For external level indication the equipment is available with an actual-value output 4 - 20 mA. The parameter settings can be secured with the help of a password to prevent unauthorised users from access and editing. The default password cannot be changed.

#### Potentially explosive areas

The equipment must not be used in potentially explosive areas.

#### Technical data

##### Supply voltage

24 VDC, + / -20 %

##### Fuse

external 0.5 A (semi-delay)

##### Power consumption

4 W

##### Connection for level electrode, level transmitter (switch-selectable)

1 input for level electrode NRG 21... and NRG 26-21, with 3 poles and screen or

1 analogue input 4-20 mA, e. g. for level transmitter NRG 26-., with 2 poles and screen.

##### Supply voltage for level electrode

12 VDC

##### Outputs

**NRS 2-50, NRS 2-51:** 2 volt-free change-over contacts, 8 A 250 V AC / 30 V DC  $\cos \varphi = 1$ .

De-energizing delay 3 sec. (MIN / MAX alarm, switchpoint adjustable).

**NRS 2-51:** 1 volt-free change-over contact,

8 A 250 V AC / 30 V DC  $\cos \varphi = 1$ .

(e. g. feedwater pump ON, switchpoint adjustable).

Provide inductive loads with RC combinations according to manufacturer's specification to ensure interference suppression.

**NRS 2-50, NRS 2-51:** 1 analogue output 4-20 mA, max. load 500 ohm, e. g. for actual-value indication.

##### Indicators and adjusters

1 rotary button with integrated pushbutton "Test" for simulating MIN / MAX alarm and setting the parameter,

1 seven-segment LED display, four digits, green

2 red LEDs for MIN / MAX alarm,

1 amber LED, e. g. for "Feedwater pump ON" (NRS 2-51),

1 code switch, 4 poles, for configuration

##### Housing

Housing material: base: polycarbonate, black;

Front: polycarbonate, grey.

Terminal strips separately detachable.

Fixing of housing: Mounting clip on supporting rail TH 35, EN 60715

##### Electrical safety

Contamination class 2.

##### Protection

Housing: IP 40 to EN 60529

Terminal strip: IP 20 to EN 60529

with panel adaptor: IP 65 to EN 60529

##### Weight

Approx. 0.2 kg

##### Further conditions:

##### Ambient temperature

when system is switched on: 0 ... 55 °C,

during operation: -10 ... 55 °C

##### Transport temperature

-20 ... +80 °C (< 100 hours), defrosting time of the

de-energized equipment before it can be put into operation: 24 hours.

##### Storage temperature

-20 ... +70 °C, defrosting time of the de-energized equipment before it can be put into operation: 24 hours.

##### Relative humidity

max. 95%, no moisture condensation

# Level Switch NRS 2-50, NRS 2-51

## Important Notes

The level switch NRS 2-50, NRS 2-51 is clipped onto the support rail in the control cabinet. Alternatively, the NRS 2-50, NRS 2-51 can be assembled into a panel adaptor (stock code # 441553) and then installed in the door of a control cabinet.

The equipment is supplied with 24 V DC and fused with an external semi-delay fuse 0.5 A.

The power supply unit must be electrically isolated from dangerous contact voltages and must meet at least the requirements on double or reinforced isolation according to one of the following standards: EN 61010-1, EN 60730-1, EN 60950-1 or EN 62368-1.

To prevent the welding together of contacts provide an external slow-blow fuse T 2.5 A or 1.0 A (TRD 604, 72 hrs. operation) for the output contacts.

When switching off inductive loads, voltage spikes are produced that may impair the operation of control systems. Connected inductive loads must be provided with suppressors such as RC combinations as specified by the manufacturer.

To connect the level electrode / the level transmitter use screened multi-core control cable with a min. conductor size 0.5 mm<sup>2</sup>, e. g. LiYCY 4 x 0.5 mm<sup>2</sup>, max. length: 100 m.

Make sure that connecting cables leading to the level electrodes are segregated and run separately from power cables.

## Order & Enquiry Specification

### Level switch type NRS 2-50

GESTRA SPECTOR<sub>module</sub>

Level switch with MIN / MAX alarm

Output: 2 volt-free change-over contacts MIN/MAX alarm

De-energizing delay: 3 seconds

Supply voltage: 24 V DC, 4 W

1 actual-value output 4-20 mA

### Level controller type NRS 2-51

GESTRA SPECTOR<sub>module</sub>

ON/off level controller with MIN / MAX alarm

Output: 3 volt-free change-over contacts for pump / MIN and MAX alarm

De-energizing delay: 3 seconds

Supply voltage: 24 V DC, 4 W

1 actual value output 4-20 mA

## Key

- 1 Upper terminal strip
- 2 Lower terminal strip
- 3 Housing
- 4 Supporting rail type TH 35, EN 60715
- 5 Connection of supply voltage 24 V DC with fuse 0.5 A (semi-delay), provided on site
- 6 Level electrode NRG 21-..; NRG 26-21  
Up to three NRS/NRR 2-5.. can be connected. (parallel connection)
- 7 Level transmitter NRGT 26-.., 4-20 mA, with earthing point. Up to three NRS/NRR 2-5.. can be connected. (series connection)
- 8 Central earthing point (CEP) in control cabinet
- 9 MIN output contact, de-energizing delay: 3 sec.
- 10 MAX output contact, de-energizing delay: 3 sec.
- 11 Actual value output 4-20 mA
- 12 Pump output contact

## Directives and Standards

For more information on the conformity of the equipment as well as applied Directives and Standards please refer to our Declaration of Conformity and associated certificates and/or approvals.

Supply in accordance with our general terms of business.

## Dimensions

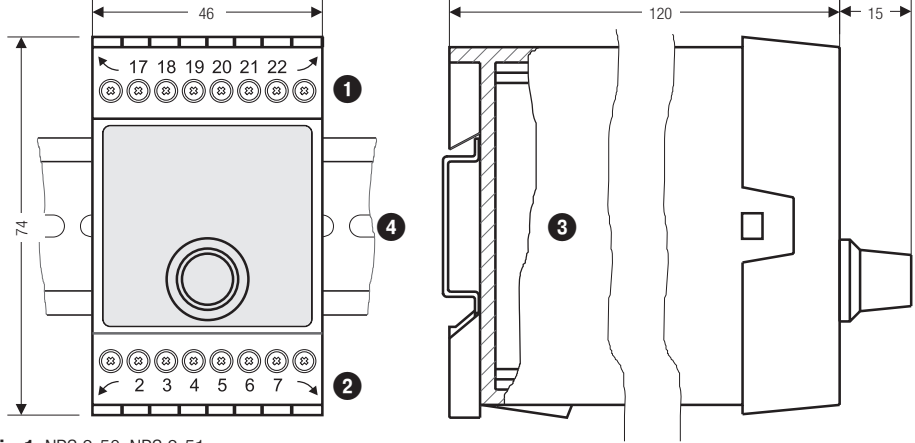

Fig. 1 NRS 2-50, NRS 2-51

## Electrical connection NRS 2-50

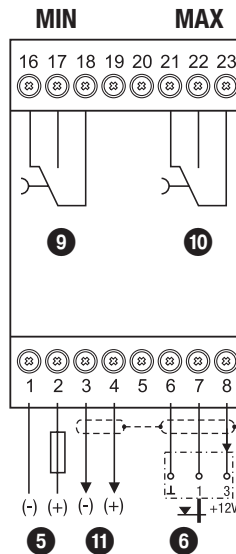

Fig. 2

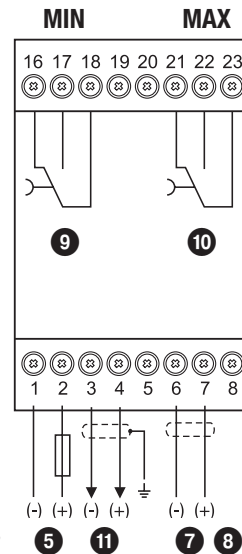

Fig. 3

## Electrical connection NRS 2-51

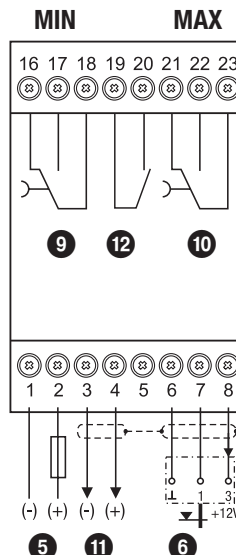

Fig. 4

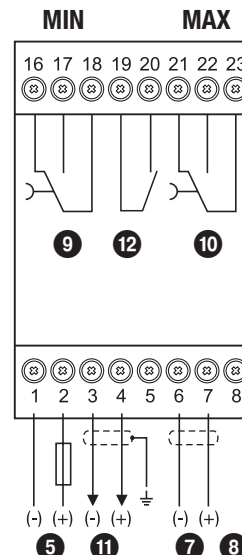

Fig. 5

# GESTRA AG

Münchener Straße 77, 28215 Bremen, Germany  
Telefon +49 421 3503-0, Telefax +49 421 3503-393  
E-mail info@de.gestra.com, Web www.gestra.com

