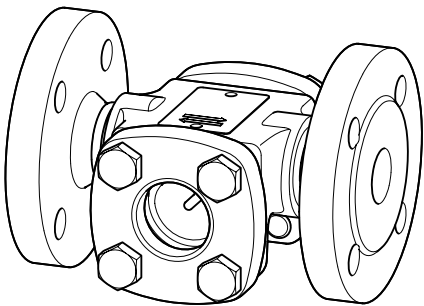

VK 14, DN 15-25

 VK 14, DN 40-50
 VK 16, DN 15-50

Vaposcope® Sight glasses

VK 14, PN 16

VK 16, PN 40

DN 15, 20, 25, 40, 50

Description

The VK 14 and VK 16 sight glasses are designed for monitoring the flows of fluid in pipes. The sight glass is fitted upstream of the steam trap, allowing users to recognise any loss of steam or banking-up of condensate in steam traps.

Design

VK 14

Straight-through type body with parallel sight glasses made from borosilicate glass for fluids \leq pH 9 at either end. The equipment has no moving parts.

Optional extras: mica shields

VK 16

Straight-through type body with parallel sight glasses made from borosilicate glass for fluids \leq pH 10 at either end. The equipment has no moving parts.

Fitted with mica shields as standard.

Fluids

The equipment is designed for the following fluids (in accordance with the EU Pressure Equipment Directive or Pressure Equipment (Safety) Regulations in the UK):

VK 14, VK 16

- Group 2 fluids

Chemical and corrosive influences must be taken into consideration.

Use in potentially explosive atmospheres

The equipment does not have its own potential source of ignition (as per ATEX Directive). Please note the following:

The high temperature of the fluid can cause the system to heat up to the point of ignition. If the equipment is used in potentially explosive atmospheres, the plant manufacturer or plant operator is responsible for preventing temperatures on the surface of the equipment that could lead to ignition.

Once installed, static electricity may arise between the equipment and the connected system.

If the equipment is used in potentially explosive atmospheres, the plant manufacturer or owner is responsible for discharging or preventing possible static charge.

Function

Steam and condensate flow along the pipe to the steam trap in separate phases (steam/condensate). An intact steam trap should therefore be set to remove only condensate and not steam.

Connections



We reserve the right to design connections as welding neck flanges, socket-weld ends or butt-weld ends via transition pieces.

VK 14

- Flange EN 1092-1 B1, PN 16

VK 16

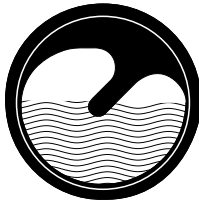
- Flange EN 1092-1 B1, PN 40
- Flange ASME B 16.5, Class 150 RF
- Flange ASME B 16.5, Class 300 RF
- Screwed socket ISO 228-1, G
- Screwed socket ASME B 16.11, NPT
- Socket-weld end DIN EN 12760 / ASME B 16.11, Class 3000

Normal operation	Banking-up of condensate	Live steam leakage
		
The tip of the deflector is immersed in the condensate. Steam can be seen in the top section and condensate at the bottom.	Condensate covers the entire sight glass. No flow is visible.	The tip of the deflector is surrounded by steam. Condensate is visible at the bottom edge of the sight glass.
Condensate is fed continuously to the steam trap. The steam trap is working correctly.	Condensate is not being removed at a sufficient rate.	Steam reaches the downstream pipe.
No action necessary.	Drain the pipe.	Check that the steam trap is not leaking and is in perfect condition. Service the defective steam trap.

Material

VK 14

Component	EN	ASTM' / ASME
Body	5.1301	A 126 Class B
Union nut ²	1.1181	A 194-2H
Flange ³	1.0460	SA 105
Bolts for body ⁴	5.6	–
Sight glass	MAXOS® borosilicate glass, DIN 7080	
Sight glass gasket	Graphite/CrNi	

¹ ASTM material is comparable to the EN material. Pay attention to differences in chemical and physical properties. For more information, contact the manufacturer.

² For fastening the sight glass of the DN 15–25, to ISO 8434-1, type N, series S

³ For fastening the sight glass of the DN 40–50

⁴ Hexagon head bolt M16 x 40, EN 24017, for fastening the sight glass

VK 16

Component	EN	ASTM/ASME
Body	1.0460	SA 105
Application	1.0619	SA 216 WCB
Flange ¹	1.0460	SA 105
Bolts for body ²	5.6	–
Sight glass	MAXOS® borosilicate glass, DIN 7080	
Sight glass gasket	Graphite/CrNi	

¹ For fastening the sight glass of the DN 40–50

² Hexagon head bolt M16 x 40, EN 24017, for fastening the sight glass

Pressure and temperature ratings

VK 14 with flange PN16

p Pressure ¹	barg	16.0	16.0	14.4	12.8	11.2	9.6
T Temperature ¹	°C	–10 — 20	120	150	200	250	280 ²
pH value		≤ 9					

¹ Ratings for strength of body to EN 1092-2

² With retrofitted mica shields (optional), the temperature increases to 300°C.

VK 16, flange PN40, flange CL300, screwed socket G, screwed socket NPT, socket-weld end EN/ASME CL3000

p Pressure ¹	barg	40.0	37.1	35.2	33.3	30.4	27.6
T Temperature ¹	°C	–10 — 20	100	150	200	250	300
pH value		≤ 10					

¹ Ratings for strength of body to EN 1092-1

VK 16 with flange CL150

p Pressure ¹	barg	19.6	17.7	15.8	13.8	12.1	10.2
T Temperature ¹	°C	–29 — 38	100	150	200	250	300
pH value		≤ 10					

p Pressure ¹	psig	285	285	260	230	200	148
T Temperature ¹	°F	–20 — 100	100	200	300	400	572
pH value		≤ 10					

¹ Ratings for strength of body to ASME B16.5

Vaposcope® Sight glasses
VK 14, VK 16

VK 14, DN 15–25

No.	Designation
1	Body with name plate
2	Gasket
3	MAXOS® sight glass
4	Spherical washer
5	Union nut
6	Mica shield (optional)

Equipment parts
VK 14, DN 15–25

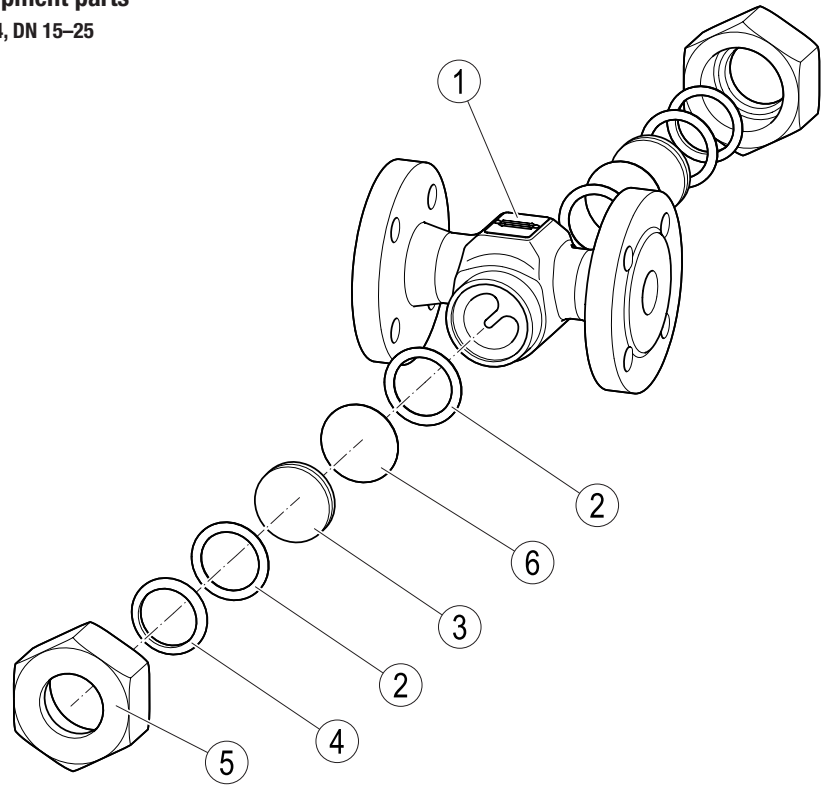

VK 14, DN 40–50 and VK 16, DN 15–50

No.	Designation
1	Body with name plate
2	Gasket
3	MAXOS® sight glass
6	Mica shield (optional VK 14)
7	Flange
8	Hexagon head bolt (8 x)

VK 14, DN 40–50 and VK 16, DN 15–50

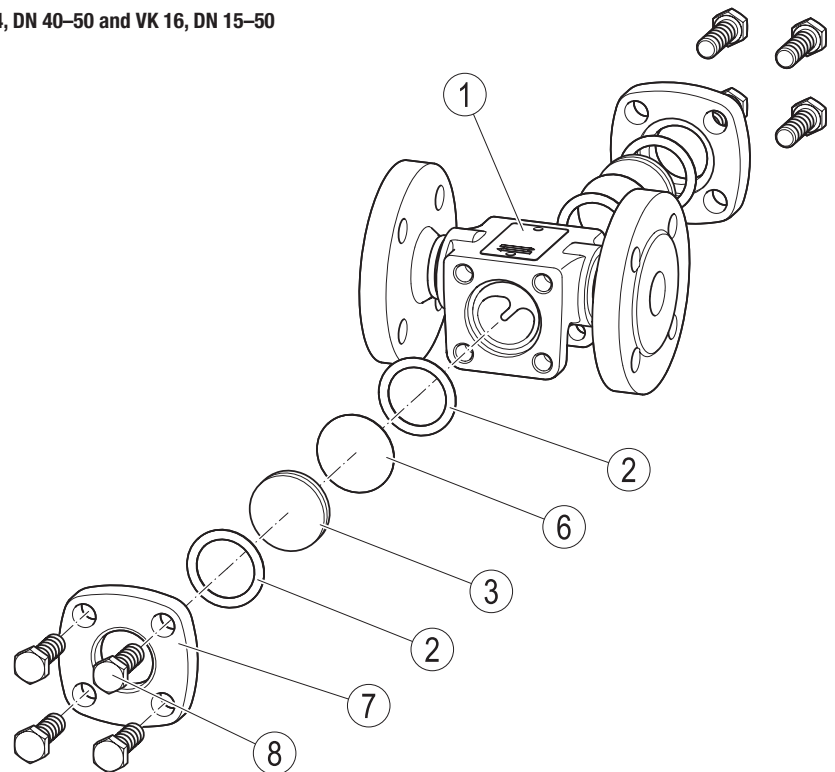

Installation

Upstream of the steam trap, with the tip of the deflector pointing downwards and in accordance with the direction indicated by the flow arrow. For installation in vertical and horizontal pipes without modification.

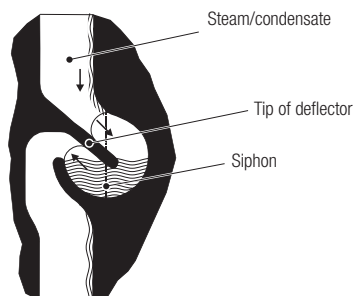
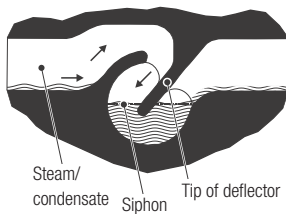

Vaposcope® Sight glasses VK 14, VK 16

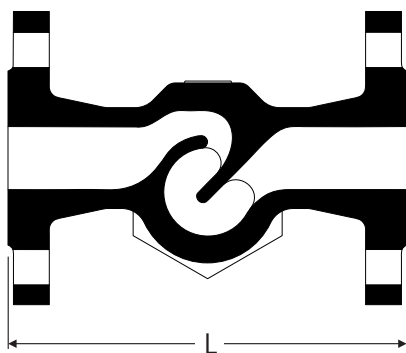

VK 14, DN 15-25

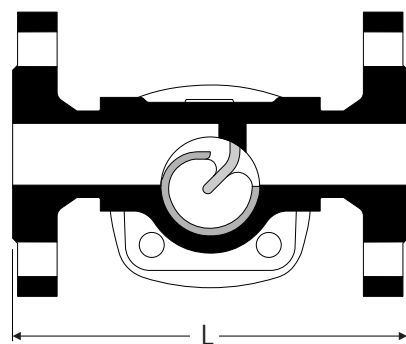

VK 14, DN 40-50
VK 16, DN 15-50

How to order

GESTRA Vaposcope® sight glass

Type: VK 14 (5.1301)
VK 16 (1.0460)

Connection: Flange / socket-weld end /
screwed socket G / screwed socket NPT

Nominal size: DN 15 – 25, 40, 50
NPS 1/2" – 1", 1 1/2", 2"

Pressure rating: VK 14 PN16
VK 16 PN40 / CL150

When ordering please state

Service pressure, service temperature, pH value of the fluid.

Acceptance inspections

An inspection certificate to EN 10204 can be provided as verification of material and construction tests. All inspection requirements must be included in the request for a quote or in the order. Once a product has been delivered, inspection certificates can no longer be issued. The standard test scope and costs of the above-mentioned test certificates can be found in our price list "Test and Inspection Charges for Standard Equipment". If you require a different inspection scope, please request a separate quote.

Directives and standards

You can find details on the conformity of the equipment and the relevant standards and directives, where applicable, in the Declaration of Conformity and associated certificates or approvals.

Please note our general terms of business.

Dimensions and weights

VK 14 with flange PN16

Nominal size	DN	15	20	25	40	50
	NPS	1/2"	3/4"	1"	1 1/2"	2"
L Length	mm	130	150	160	200	230
Weight	kg	3.4	4.0	4.5	14.6	16.2

VK 16, flange PN40, flange CL150, flange CL300

Nominal size	DN	15	20	25	40	50
	NPS	1/2"	3/4"	1"	1 1/2"	2"
L Length	mm	150	150	160	230	230
Weight	kg	4.0	5.0	5.5	13.0	15.5

VK 16, screwed socket G, screwed socket NPT, socket-weld end EN/ASME CL3000

Nominal size	DN	15	20	25	40	50
	NPS	1/2"	3/4"	1"	1 1/2"	2"
L Length	mm	95	95	95	130	230
Weight	kg	2.9	3.1	3.0	8.5	9.0

GESTRA AG

Münchener Straße 77, 28215 Bremen, Germany
Tel. +49 421 3503 0, Fax +49 421 3503 393
e-mail info@de.gestra.com, website www.gestra.com

