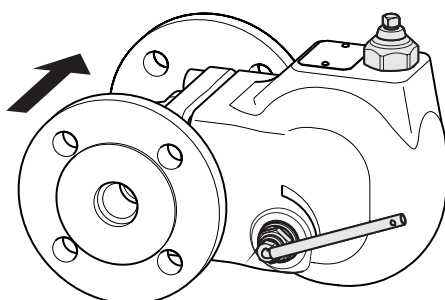
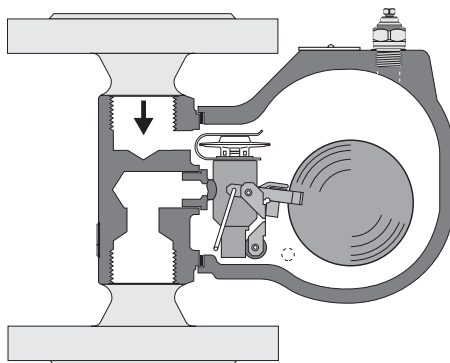

 UNA 14hl, UNA 16hl, UNA 16Ahl
Standard

 UNA 14hl, UNA 16hl, UNA 16Ahl
Including optional
manual vent valve and
float lifting lever

 UNA 14v, UNA 16v, UNA 16Av
DUPLIX control unit
Including manual vent valve

Connections

We reserve the right to design connections as welding neck flanges, socket-weld ends or butt-weld ends via transition pieces.

UNA 14

- Flange EN 1092-1 B1, PN 25
- Screwed socket ISO 228-1, G
- Screwed socket ASME B 16.11, NPT

UNA 16, UNA 16A

- Flange EN 1092-1 B1, PN 40
- Flange ASME B 16.5, Class 150 RF
- Screwed socket ISO 228-1, G
- Screwed socket ASME B 16.11, NPT
- Socket-weld end DIN EN 12760
- Socket-weld end ASME B16.11, Class 3000
- Butt-weld end EN 12627, welded joint geometry ISO 9692-1, code no. 1.3 (30° chamfer)

Ball Float Steam Trap

UNA 14, PN25

UNA 16, PN40 / CL150, Carbon Steel

UNA 16A, PN40 / CL150, Stainless Steel

DN 15, 20, 25, NPS ½", ¾", 1"

Description

Type UNA 14, UNA 16 and UNA 16A ball float steam traps are used to discharge condensate in steam and other gases or gaseous mixtures. UNA 14, UNA 16 and UNA 16A are steam traps with a ball float and sealing unit with rolling ball. As their operation is unaffected by backpressure, the equipment is suitable for universal use.

- Suitable for large condensate flowrates

Design

The equipment consists of a body with flange-mounted cover and a control unit.

The different equipment versions allow you to adjust the direction of flow of the equipment to suit your system. The equipment can also be subsequently converted to an "h/v" version by rotating the cover and the controller.

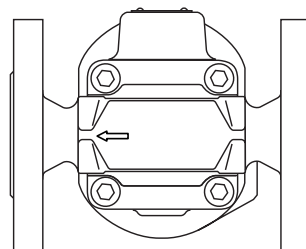
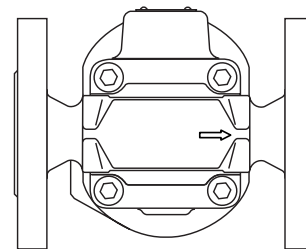
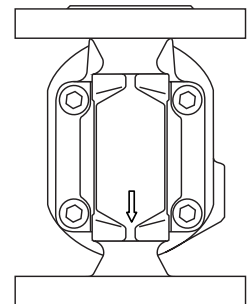
 Position "hl"
Direction of flow to the left
for a horizontal pipe

 Optional position "hr"
Direction of flow to the right
for a horizontal pipe

 Position "v"
Downward flow for vertical
pipes

Design

The control unit is available with different venting options and orifices.

- Duplex (level-dependent float control and automatic, temperature-dependent venting by the GESTRA "5N2" membrane regulator capsule): for saturated steam systems.
- Simplex (level-dependent float control): Float control especially suitable for cold condensate and distillate.
- Simplex R (level-dependent float control and continuous ventilation via internal bypass/"tube"): Suitable for draining rotating cylinders.

Orifices

The maximum differential pressure ΔPMX of the equipment depends on the orifice (O) used.

Orifice	ΔPMX bar	UNA 14	UNA 16	UNA 16A
4	4	X	X	X
13	13	X	X	X
22	22	—	X	X

Optional extras

- Float lifting lever and vent hole
- Manual vent valve and sealing plug
- Float lifting lever and manual vent valve
- Perbunan rolling ball

Fluids

The equipment is designed for the following fluids (in accordance with the EU Pressure Equipment Directive or Pressure Equipment (Safety) Regulations in the UK):

UNA 14

- Group 2 fluids

UNA 16, UNA 16A (stainless steel):

- Group 1 fluids
- Group 2 fluids

Chemical and corrosive influences must be taken into consideration.

Ball Float Steam Trap UNA 14, UNA 16, UNA 16A

Use in potentially explosive atmospheres

The equipment does not have its own potential source of ignition (as per ATEX Directive). Please note the following:

During operation, avoid excessive surface temperatures caused by the fluid. The equipment itself does not generate higher surface temperatures.

Once installed, static electricity may arise between the equipment and the connected system. If the equipment is used in potentially explosive atmospheres, the plant manufacturer or owner is responsible for discharging or preventing possible static charge.

If it is possible for fluid to escape, e.g. through actuating mechanisms or leaks in threaded joints, the plant manufacturer or owner must take this into consideration when dividing the area into zones.

Function

The control unit opens the orifice (O) based on the fill level. This regulates the drainage rate.

With the orifice opened to maximum, the drainage rate depends on the diameter of the orifice.

Materials

Component	EN	ASME / ASTM
Body of UNA 14, UNA 16	1.0460	SA105
Body of UNA 16A (stainless steel)	1.4404	SA182-F316L
Cover of UNA 14	5.3103	A536 60-40-18 ¹
Cover of UNA 16	1.0619	SA216-WCB
Cover of UNA 16A (stainless steel)	1.4408	SA351-CF8M
Body gasket	Graphite/CrNi	
Membrane regulator capsule 5N2	Hastelloy/stainless steel	
Other controller parts, sealing ring	Stainless steel	

¹ ASME/ASTM material is comparable to EN material. Pay attention to differences in chemical and physical properties.

Pressure and temperature ratings

UNA 14, flange PN25, screwed socket G, screwed socket NPT

p Pressure ¹	barg	25.0	21.4	19.4	17.7	16	15.1
T Temperature ¹	°C	-10 — 50	100	200	250	300	350
Δ PMX Max. admissible differential pressure at O 4	bar	4					
Δ PMX Max. admissible differential pressure at O 13	bar	13					

¹ Ratings for strength of body/cover to EN 1092-1

UNA 16, flange PN40, screwed socket G, screwed socket NPT, socket-weld end EN, butt-weld end

p Pressure ¹	barg	40.0	34.2	31.0	25.7	24.1	22.8
T Temperature ¹	°C	-10 — 50	100	200	300	350	400
Δ PMX O 4	bar	4					
Δ PMX O 13	bar	13					
Δ PMX O 22	bar	22					

¹ Ratings for strength of body/cover to EN 1092-1

Perbunan rolling ball, differential pressure 16 bar max. 40 °C (for O 22 and O 13 only)

Ball Float Steam Trap
UNA 14, UNA 16, UNA 16A

UNA 16, flange CL150

p Pressure ¹	barg	19.6	17.7	13.8	10.2	6.5	5.5
T Temperature ¹	°C	-29 — 38	100	200	300	400	425
Δ PMX O 4	bar	4					
Δ PMX O 13	bar	13					
p Pressure ¹	psig	285	260	230	200	170	140
T Temperature ¹	°F	-20 — 100	200	300	400	500	600
Δ PMX O 4	psi	58					
Δ PMX O 13	psi	188					

¹ Ratings for strength of body/cover to ASME B16.5

UNA 16A, flange PN40, screwed socket G, screwed socket NPT

p Pressure ¹	barg	40	37.9	34.4	31.8	29.9	27.6
T Temperature ¹	°C	-10 — 50	100	150	200	250	300
Δ PMX O 4	bar	4					
Δ PMX O 13	bar	13					
Δ PMX O 22	bar	22					

¹ Ratings for strength of body/cover to EN 1092-1

Perbunan rolling ball, differential pressure 16 bar max. 40 °C (for O 22 and O 13 only)

UNA 16A, flange CL150

p Pressure ¹	barg	15.9	13.3	12	11.2	10.5	10.0
T Temperature ¹	°C	-29 — 38	100	150	200	250	300
Δ PMX O 4	bar	4					
Δ PMX O 13	bar	13					
p Pressure ¹	psig	230	195	175	160	150	140
T Temperature ¹	°F	-20 — 100	200	300	400	500	600
Δ PMX O 4	psi	58					
Δ PMX O 13	psi	188					

¹ Ratings for strength of body/cover to ASME B16.5

Perbunan rolling ball, differential pressure 16 bar max. 40 °C (for O 22 and O 13 only)

Ball Float Steam Trap

UNA 14, UNA 16, UNA 16A

No.	Designation
1	Direction of flow arrow
2	Body
3	Body gasket
4	Control unit (here: SIMPLEX model)
5	Ball float
6	Name plate
7	Cover
8	Drain outlet in orifice (O)
9	4 hexagon socket head bolts

Control units

No.	Designation
4	SIMPLEX control unit
10	SIMPLEX R control unit
11	Continuous ventilation ("tube")
12	DUPLEX control unit
13	Clamp for membrane regulator capsule
14	Membrane regulator capsule 5N2

Optional extras

No.	Designation
15	Sealing plug
16	Manual vent valve
17	Sealing ring
18	Manual float lifting lever

Equipment parts

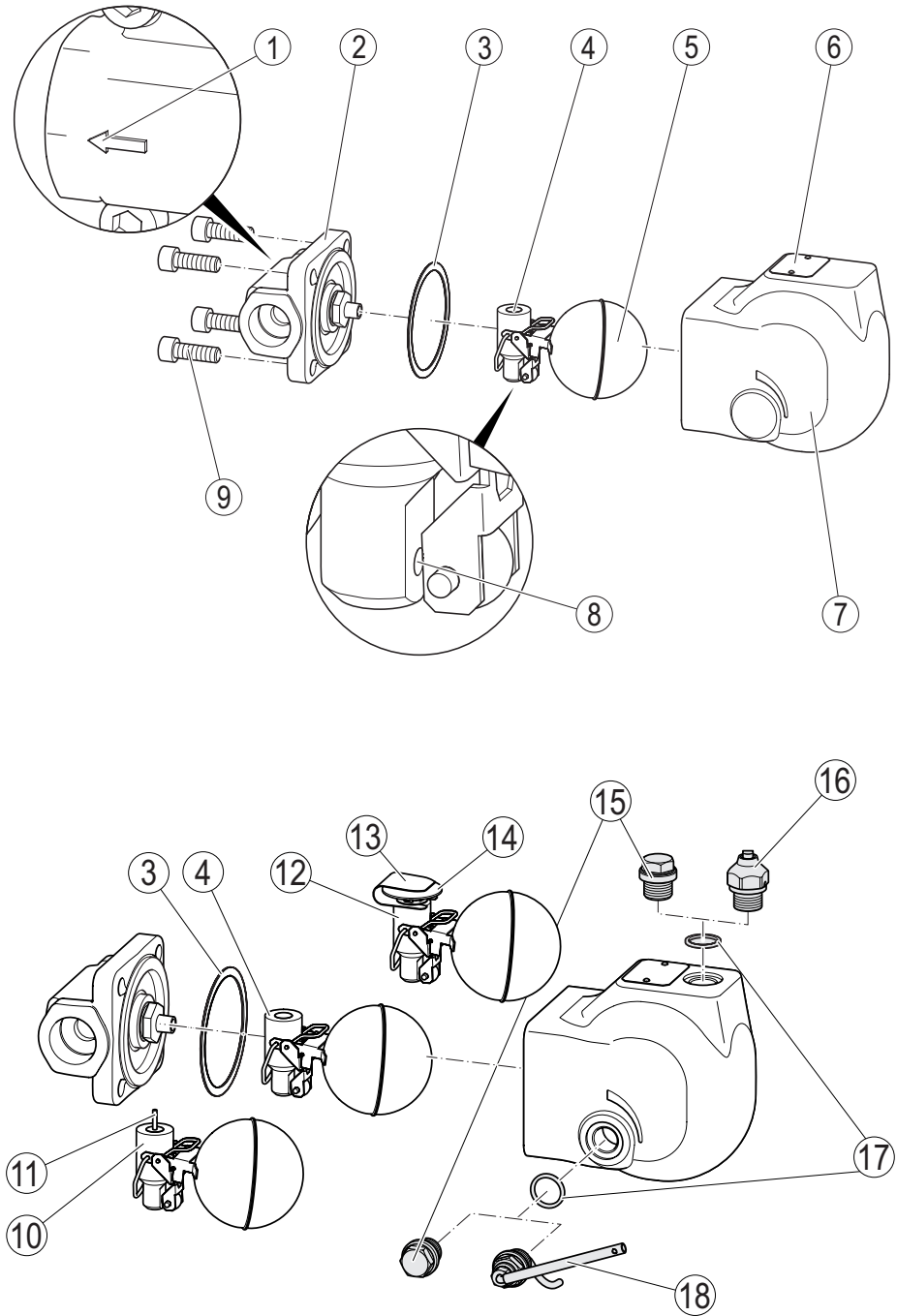

Ball Float Steam Trap UNA 14, UNA 16, UNA 16A

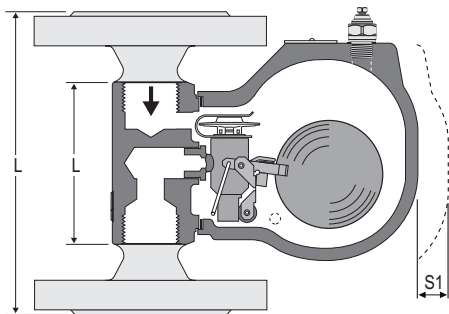

UNA 14v, UNA 16v, UNA 16Av
DN 15 — 25

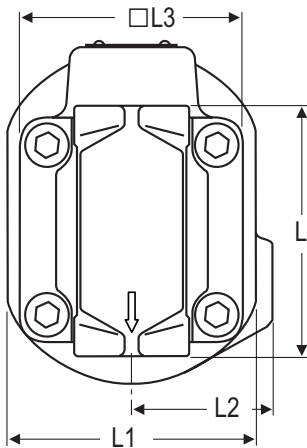
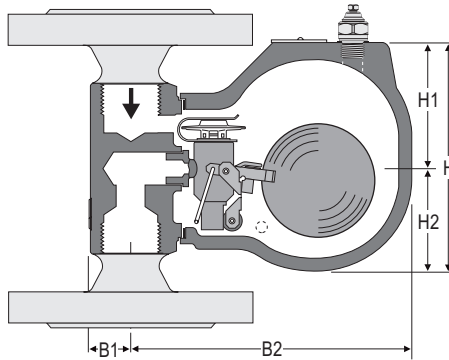

UNA 14v, UNA 16v, UNA 16Av
DN 15 — 25

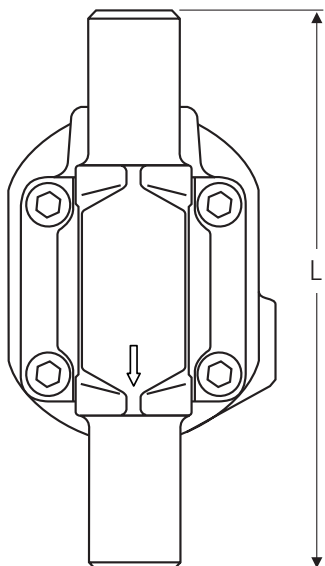

UNA 16v, UNA 16Av, butt-weld end via transition pieces

Dimensions and weights

All equipment

	mm	inches
H	127	5"
H1	70	2.8"
H2	57	2.2"
B1	22	0.9"
B2	156	6.1"
L1	94	3.7"
L2	53	2.1"
L3	84	3.3"
S1 Cover service dimensions	120	4.7"

Plus 25 mm (1") if fitted with manual vent valve.

Plus 35 mm (1.4") if fitted with manual float lifting lever.

Plus 13 mm (0.5") if fitted with sealing plug.

Equipment with attached socket wrench requires additional clearance of 100 mm (4").

UNA 14, flange PN 25, UNA 16, UNA 16A, flange PN 40, CL125

		PN			CL		
Nominal size	DN	15	20	25	15	20	25
	NPS	½"	¾"	1"	½"	¾"	1"
L Length	mm	150	150	160	150	150	160
	inches	5.9"	5.9"	6.3"	5.9"	5.9"	6.3"
D Flange Ø	mm	95	105	115	88.9	98.4	107.9
	inches	3.7"	4.1"	4.5"	3.5"	3.9"	4.2"
Weight of UNA 14	kg	6.5	7.2	7.6	—	—	—
	lb	14.3	15.9	16.8	—	—	—
Weight of UNA 16	kg	7	7.5	8.1	6.4	6.9	7.5
	lb	15.4	16.5	17.9	14.1	15.2	16.5
Weight of UNA 16A	kg	7	7.7	8.1	6.5	7.1	7.5
	lb	15.4	17	17.9	14.3	15.7	16.5

UNA 14, UNA 16, UNA 16A, screwed socket G, screwed socket NPT, socket-weld end EN/ASME

Nominal size	DN	15	20	25
	NPS	½"	¾"	1"
L Length	mm	95	95	95
	inches	3.7"	3.7"	3.7"
Weight of UNA 14	kg	5	5	4.8
	lb	11	11	10.6
Weight of UNA 16	kg	5.5	5.5	5.3
	lb	12.1	12.1	11.7
Weight of UNA 16A	kg	5.6	5.6	5.4
	lb	12.3	12.3	11.9

UNA 16, butt-weld end EN

Nominal size	DN	15	20	25
	NPS	½"	¾"	1"
For pipe	mm	21.3 × 2.0	26.9 × 2.3	33.7 × 2.6
L Length	mm	200	200	200
Weight of UNA 16	kg	6	6	6.1
	lb	13.2	13.2	13.4

Ball Float Steam Trap UNA 14, UNA 16, UNA 16A

Capacity chart

The chart shows the maximum capacities for hot condensate for the orifices (O).

To determine the cold water capacity, multiply the flowrate by factor F.

The capacities are dependent on the differential pressure (service pressure). The differential pressure is the difference between the inlet and outlet pressures and depends among other things on the run of the condensate line. If the condensate downstream of the trap is lifted, the differential pressure (working pressure) is reduced by approximately 1 bar for 7 m (or 2 psi for 3 feet) lift.

The maximum admissible differential pressure is dependent on the cross-sectional flow area of the orifice and the density of the liquid being discharged.

As standard, the traps for removing condensate from steam are available for the following maximum differential pressures:

UNA 14: up to 4 or 13 bar

UNA 16, UNA 16A: up to 4, 13 or 22 bar

Capacity chart

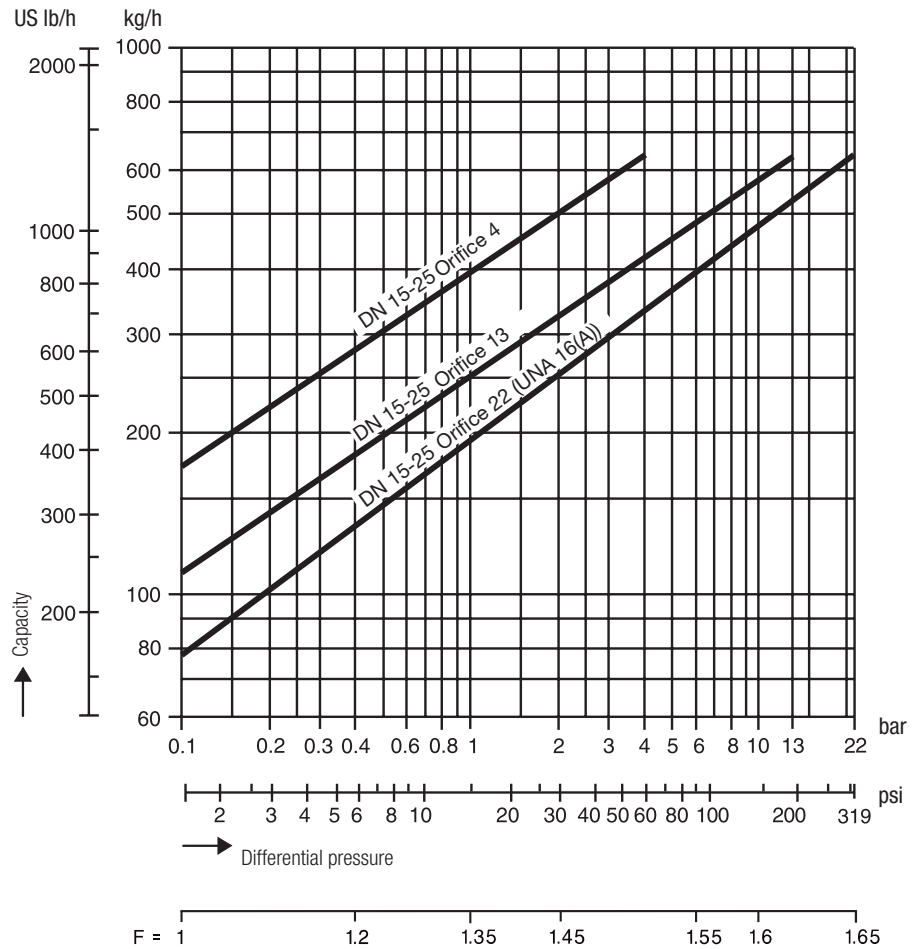

Additional cold-water start-up capacity due to membrane regulator capsule (Duplex version)

Δp	bar	1	2	3	4	6	8	10	13	18	22
Capacity	~ kg/h	180	230	330	410	480	540	600	680	760	840

Acceptance inspections

An inspection certificate to EN 10204 can be provided as verification of material and construction tests. All inspection requirements must be included in the request for a quote or in the order. Once a product has been delivered, inspection certificates can no longer be issued. The standard test scope and costs of the above-mentioned test certificates can be found in our price list "Test and Inspection Charges for Standard Equipment". If you require a different inspection scope, please request a separate quote.

Directives and standards

You can find details on the conformity of the equipment and the relevant standards and directives, where applicable, in the Declaration of Conformity and associated certificates or approvals.

Please note our general terms of business.

GESTRA AG

Münchener Straße 77, 28215 Bremen, Germany
Tel. +49 421 3503 0, Fax +49 421 3503 393
e-mail info@de.gestra.com, website www.gestra.com

