

LRG 16-4

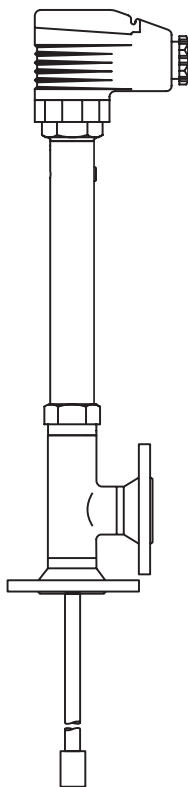

LRG 16-4 with T-type connector

Conductivity Electrode LRG 16-4

Description

The conductivity electrode LRG 16-4 together with the conductivity switch LRS 1-.. or conductivity controller LRR 1-.. is designed for measuring and monitoring electrical conductivity in conductive fluids.

If used as conductivity limiter or continuous blowdown controller in steam boilers, the conductivity electrode LRG 16-4 can be used with the following equipment:

Conductivity switch LRS 1-50
 Conductivity controller LRR 1-50
 Conductivity controller LRR 1-52

Function

The conductivity electrode LRG 16-4 is used in combination with the following equipment as conductivity limiter and continuous blowdown controller in steam boilers:

Conductivity switch LRS 1-50
Conductivity controller LRR 1-50
Conductivity controller LRR 1-52

In addition the equipment can monitor conductivity in condensate and feedwater systems and in cooling and cleaning water.

The conductivity electrode works according to the conductivity measurement principle and, in conjunction with conductivity switches or controllers, monitors the conductivity in conductive fluids.

A short circuit or wire breakage in the conductivity electrode will trigger an error message in the conductivity switch or controller.

Directives and standards

Pressure Equipment Directive 2014/68/EU

The conductivity control and monitoring equipment LRG 1-..., LRS 1-5-.., LRR 1-5-.. meets the safety requirements of the Pressure Equipment Directive (PED). The conductivity control & monitoring equipment is EC type approved according to EN 12952/EN 12953. These Directives state, among other things, the requirements made on limiting systems and equipment for steam boiler plants and (pressurised) hot-water installations.

VdTÜV Bulletin "Water Monitoring 100"

The conductivity electrode LRG 16-4 in conjunction with the following conductivity switches and controllers is type approved according to VdTÜV Bulletin "Wasserstand 100": LRS 1-50, LRR 1-50 and LRR 1-52.

Type approval no. TÜV . WÜL . 12-017, 12-018. The VdTÜV Bulletin "Water Monitoring 100" states the requirements made on water monitoring equipment.

ATEX (Atmosphère Explosible)

The equipment constitutes a simple item of electrical equipment as defined in DIN EN 50020 section 5.4. According to the European Directive 2014/34/EU the equipment must be equipped with approved Zener barriers if used in potentially explosive areas. Applicable in Ex zones 1, 2 (1999/92/EC). The equipment does not bear an Ex marking.

UL/cUL (CSA) Approval

The equipment meets the requirements of: UL 508 and CSA C22.2 No. 14-13, Standards for Industrial Control Equipment. File E243189.

Technical data

Service pressure

PN 40, max. 32 bar at 238 °C

Mechanical connection

Screwed G 3/8 ISO 228-1

Materials

Screw-in body: 1.4571, X6CrNiMoTi17-12-2
 Measuring electrode: 1.4571, X6CrNiMoTi17-12-2
 Electrode rod insulation: PTFE

Length of measurement & installation

100, 300, 400, 500, 600, 800, 1000 and 1200 mm

Cell constant

1 cm⁻¹

Electrical connection

Four-pole connector, cable glands M 16 (PG 11) with integral cable clamp

Protection

IP 65 to DIN EN 60529

Admissible ambient temperature

Max. 70 °C

Weight

Approx. 0.5 kg (without T-type connector)

Approvals

TÜV approval acc. to VdTÜV Bulletin "Water Monitoring 100": Requirements made on water monitoring equipment
 Type approval no. TÜV · WÜL · XX-017, XX-018.

UL/cUL (CSA) Approval: UL 508 and CSA C22.2 No. 14-13, Standards for Industrial Control Equipment. File E243189

Important Notes

Installation

The conductivity electrode is designed for horizontal or inclined installation. Observe the indicated distances between the lower end of the measuring electrode, the boiler wall, the smoke tubes and any other metal fittings as well as the low water level (LW). Note that the measuring surface must be constantly in contact with the water.

Electrical connection

To connect the conductivity electrode use screened multi-core control cable with a min. conductor size 0.5 mm², e.g. LiYCY 3 x 0.5 mm².

Max. cable length between conductivity electrode and switch or controller: 30 m, with conductivities from 1 to 10 µS/cm: max. 10 m.

Make sure that connecting cables leading to the equipment are segregated and run separately from power cables.

Order & Enquiry Specification

GESTRA Conductivity electrode type LRG 16-4
 PN 40, screwed G 3/8 A, ISO 228
 Measuring length and length of installationmm

Associated conductivity switch / controller

- Conductivity switch LRS 1-50
- Conductivity controller LRR 1-50, LRR 1-52

Accessories

GESTRA T-type connector, PN 40

Conductivity Electrode LRG 16-4

Dimensions

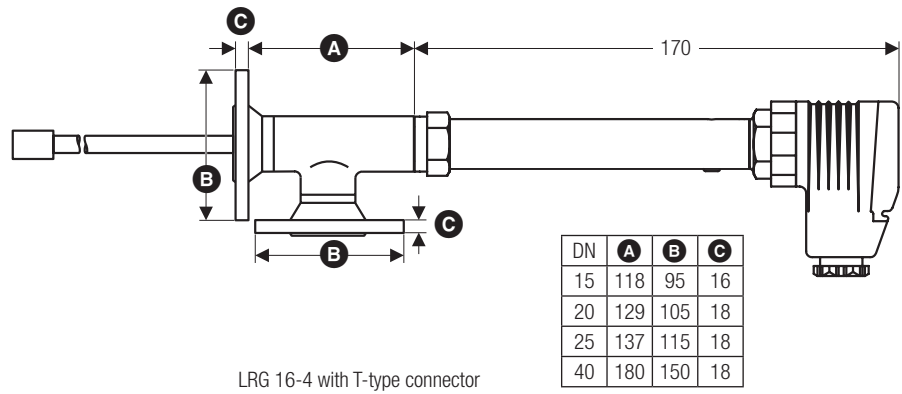
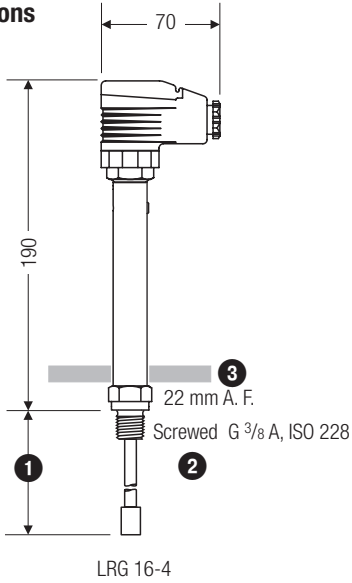

Wiring diagram for terminals in connecting plate

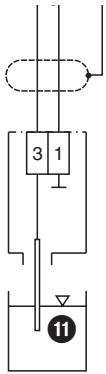

Key

- 1 Measuring length and length of installation
- 2 Electrode thread G 3/8 A, ISO 228
- 3 Thermal insulation, provided on site, d = 20 mm (outside of thermal insulation of steam boiler)
- 4 Joint ring 17 x 21, form D, DIN 7603, 2.4068, bright annealed
- 5 T-type connector
- 6 Shut-off valve GAV
- 7 Continuous blowdown valve BAE
- 8 Boiler drum
- 9 Level pot "3 MF 88.0"
- 10 Level pot "4 DB 372"
- 11 Measuring electrode

Supply in accordance with our general terms of business.

Examples of installation

Conductivity monitoring and continuous boiler blowdown, direct installation of conductivity electrode via T-type connector and connection of a continuous blowdown valve

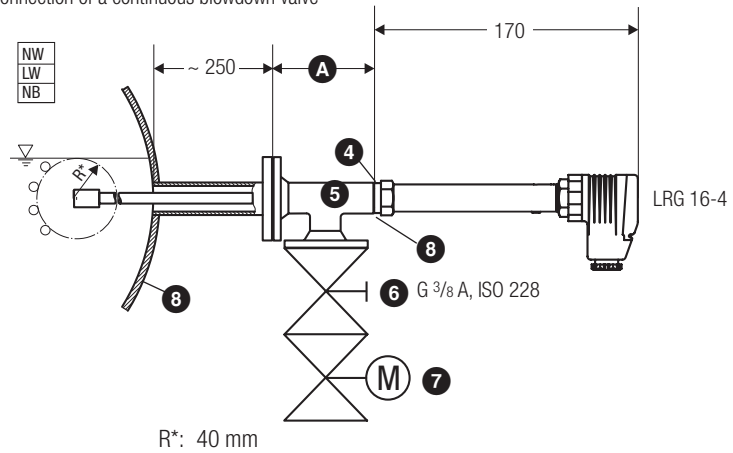

Conductivity monitoring, direct installation of conductivity electrode via flanged standpipe on the side of the boiler or installation of electrode in an external level pot

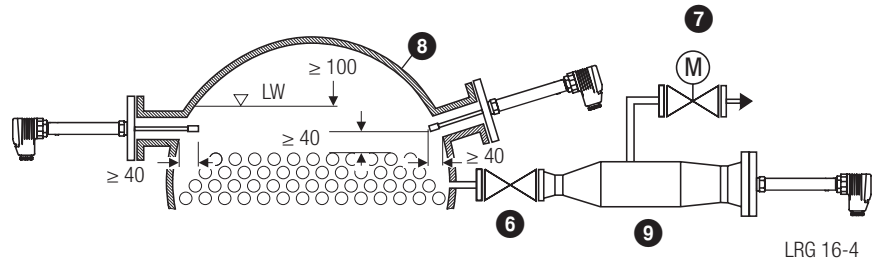

Conductivity monitoring and continuous boiler blowdown, installation of conductivity electrode in top blowdown line via separate level pot

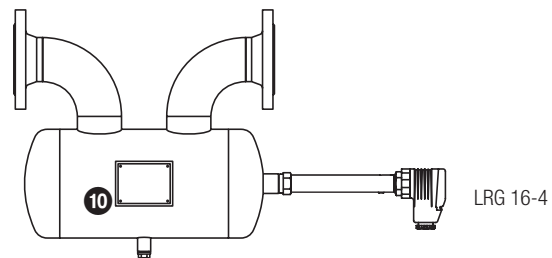

GESTRA AG

Münchener Straße 77, 28215 Bremen, Germany
 Telefon +49 421 3503-0, Telefax +49 421 3503-393
 E-mail info@de.gestra.com, Web www.gestra.de

