

ecoBolt Continuous Steam Trap Monitor

# MSB-1C, MSB-1.2C

EN  
English

Original Installation Instructions

**851089-00**

# Contents

<b>Foreword</b> .....	<b>3</b>
Availability.....	3
Formatting features in the document .....	3
<b>Safety</b> .....	<b>4</b>
Use for the intended purpose .....	4
Basic safety notes .....	4
Information on property damage or malfunctions .....	4
Qualification of personnel.....	4
Protective gear .....	5
Typographic features of warning notes.....	5
Formatting features for warnings of property damage .....	5
<b>Description</b> .....	<b>6</b>
Scope of supply and equipment specification .....	6
Task and function .....	7
<b>Storing and transporting the equipment</b> .....	<b>8</b>
Storing the equipment .....	8
Transporting the equipment .....	8
<b>Mounting and connecting the equipment</b> .....	<b>8</b>
Preparing installation .....	8
Mounting the equipment .....	9
Starting up the equipment.....	13
<b>Operation</b> .....	<b>13</b>
<b>After operation</b> .....	<b>13</b>
Switching the equipment off .....	13
Removing external dirt deposits .....	14
Maintaining the equipment.....	14
Checking the component parts for damage .....	14
Servicing the equipment and installing spare parts .....	14
<b>Troubleshooting</b> .....	<b>16</b>
<b>Putting the equipment out of operation</b> .....	<b>18</b>
Removing the equipment .....	18
Returning the equipment.....	18
Disposing of the equipment.....	19
<b>Technical data</b> .....	<b>20</b>
Dimensions and weights .....	20
Electrical data .....	21
Ambient conditions .....	21
Pressure & temperature ratings .....	21
<b>Declaration of Conformity – Standards and Directives</b> .....	<b>22</b>

## Foreword

This Installation & Operating Manual will help you ensure the correct, safe and cost-effective use of the following continuous steam trap monitoring equipment:

- ▶ MSB-1C
- ▶ MSB-1.2C

This continuous steam trap monitoring equipment is referred to below simply as 'equipment'.

The equipment consists of several assemblies:

- ▶ MSBS... sensor
- ▶ MSBA... pre-amplifier
- ▶ MSBN... LoRa node

This installation & operating manual is intended for anyone commissioning, using, operating, servicing, cleaning or disposing of this equipment and, in particular, for professional after-sales service technicians, qualified personnel and authorised and trained staff.

All of these persons must read and understand the content of this installation & operating manual.

Following the instructions given in this installation & operating manual helps avoiding danger and increases the reliability and service life of the equipment. Please note that in addition to the instructions given in this installation & operating manual you must also observe all locally applicable rules and regulations concerning the prevention of accidents as well as approved safety guidelines for good professional practice.

Please also read and follow the instructions, particularly the safety notes, in the MSBN-1C LoRa node Installation & Operating manual.

## Availability

Keep this installation & operating manual together with the plant documentation for future reference. Make sure that this installation & operating manual is available to the operator.

The installation & operating manual is part of the equipment. Please hand over this installation & operating manual when selling the equipment or passing it on.

## Formatting features in the document

Certain text elements of this installation & operating manual feature a specific typographic design. You can easily distinguish the following text elements:

Standard text

*Cross-reference*

- ▶ Listing
  - ▶ Sub-items in listings
- Steps for action.



Here you will find additional useful information and tips serving to assist you in using the equipment to its fullest potential.

# Safety

## Use for the intended purpose

The MSB-1C and MSB-1.2C continuous steam trap monitor is used to check steam traps for loss of steam and banking up of condensate outside potentially explosive atmospheres. It must not be used in potentially explosive atmospheres.

The MSB-1.2C continuous steam trap monitor is designed for use at higher noise levels than the MSB-1C.

This allows the MSB-1.2C to be used at higher pressures or condensate flowrates than the MSB-1C.

You can find the precise areas of application of the different versions together with their installation options in the data sheet.

Intended use also includes reading and adhering to all instructions in this manual and the MSBN-1C LoRa node Installation & Operating Manual. This applies in particular to the safety notes and requirements.

Use for the intended purpose also includes correct handling of the batteries used as described in the LoRa node Installation & Operating Manual. You can obtain information on correct handling from the manufacturer of the LoRa node.

Any other use of the equipment is considered to be improper.

The following use, in particular, is deemed improper use:

- Using equipment without Ex classification in a potentially explosive atmosphere
- Use of the equipment by untrained personnel

## Basic safety notes

### Explosion hazard

Do not use the equipment in potentially explosive atmospheres.

## Risk of severe injuries

- The steam traps being monitored are hot and under pressure. Only work on the steam traps if the following conditions are satisfied:
  - Avoid skin contact with the monitored steam trap and other plant components.
  - Wear suitable protective clothing.
  - Make sure there is no escaping fluid around the steam trap to be monitored.
- Risk of accident if pressure-bearing screws come loose.  
Make sure that pressure-bearing screws are not unscrewed during installation and connection.

## Risk of minor injuries

- There is a risk of cuts from sharp-edged parts of the equipment. Always wear protective gloves when working on the equipment.

## Information on property damage or malfunctions

- Incorrect installation, connection and handling can cause malfunctions and damage to electronic components.

## Qualification of personnel

A qualified person must be acquainted with and experienced in the following:

- The pertinent on-site rules and regulations for preventing fire and explosions as well as industrial safety regulations
- Working on pressure equipment
- Working with dangerous (hot or pressurized) fluids
- Observing all notes and instructions in this installation & operating manual and the applicable documents
- Working with portable instruments
- Working with personal computers (PCs)
- Working with menu-driven software
- Working with computer networks

## Protective gear

The operator must ensure that anyone working on the equipment must wear the required protective clothing and safety gear stipulated for the site of installation. The protective clothing must be suitable for the used media and must protect the wearer against safety and health hazards associated with a particular job to be carried out at the site of installation. Protective clothing & equipment must provide protection from potential hazards, in particular from injuries to:

- ▶ Head
- ▶ Eyes
- ▶ Body
- ▶ Hand
- ▶ Feet
- ▶ Hearing

Note that this list is not exhaustive. The operator must establish personal protective equipment guidelines and specify any additional protective gear that is required if the worker is exposed to a specific risk at the site of installation.

## Typographic features of warning notes

---



### **DANGER**

Notes with the heading DANGER warn against imminent dangerous situations that can lead to death or serious injuries.

---



### **WARNING**

Notes with the heading WARNING warn against possibly dangerous situations that could lead to death or serious injuries.

---



### **CAUTION**

Notes with the heading CAUTION warn against dangerous situations that could lead to minor or moderate injuries.

---

## Formatting features for warnings of property damage

---

### ***Attention!***

This information warns of a situation leading to property damage.

---

## Description

### Scope of supply and equipment specification

#### Scope of supply

The equipment assemblies are supplied individually and must be connected and installed before use.

For MSB-1C or MSB-1.2C equipment, delivery includes the following:

- ▶ MSBS-1 sensor
- ▶ MSBA-1C or MSBA-1.2C pre-amplifier with connecting cable
- ▶ MSBN-1C LoRa node type LSN50 v2 with connecting cable

#### Equipment specification

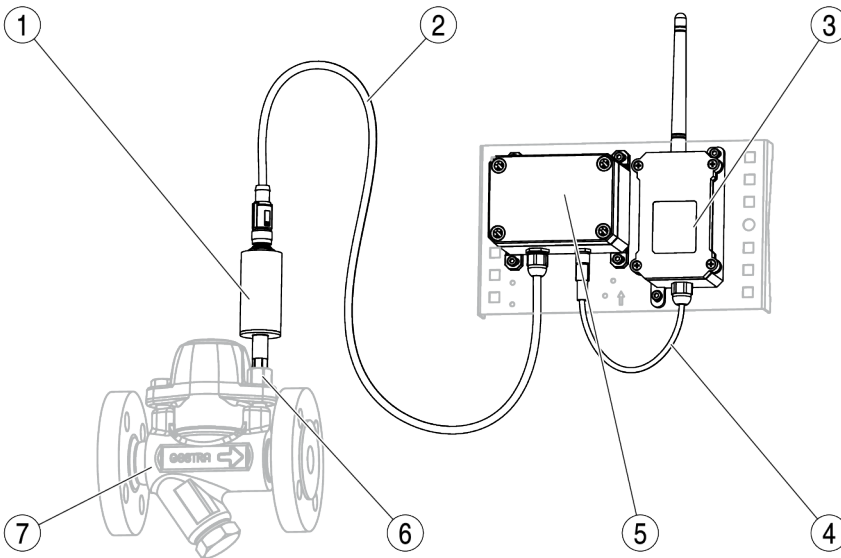

No.	Designation
1	MSBS-1 sensor
2	Sensor connecting cable
3	MSBN-1C LoRa node
4	Pre-amplifier connecting cable

No.	Designation
5	MSBA-1C, MSBA-1.2C pre-amplifier
6	Accessories (pressure-bearing screw PBS shown here as an example)
7	Steam trap (BK 45 shown here as an example)

## Optional extras

The following add-on equipment is available:

- ▶ Pressure-bearing screws (PBS) of steel or stainless steel
- ▶ 90° adapter (ADP)
- ▶ Clips (RFC) for mounting on pipes (including clip adapters)
- ▶ Mounting system for pre-amplifier and LoRa node
- ▶ LoRa gateway

Further accessories are available on request.

## Name plate

Name plates are affixed to the individual assemblies:

- ▶ MSBS-1 sensor: on the housing
- ▶ MSBA-1C, MSBA-1.2C pre-amplifier: on the side
- ▶ MSBN-1C LoRa node: on the front

The name plates contain the following indications:

- ▶ Manufacturer
- ▶ Type designation
- ▶ Serial number
- ▶ QR code
- ▶ Mark of conformity
- ▶ Disposal information
- ▶ Technical data, if applicable

## Use in potentially explosive atmospheres

Do not use the equipment in potentially explosive atmospheres.

## Task and function

### Purpose

The MSB-1C or MSB-1.2C equipment is used to monitor steam traps for loss of steam and banking up of condensate.

The MSB-1.2C equipment is intended for use at higher noise levels, e.g. at higher pressures or condensate flowrates. You can find precise information on the areas of application in the data sheet.

Monitoring enables the early detection of faulty steam traps and banking up of condensate.

The early detection of faulty steam traps increases the efficiency of the plant as a whole and reduces its energy consumption.

The detection of banked up condensate prevents damage and malfunctions in the plant as a whole.

To use the equipment, a LoRa gateway and LoRa network server are required for displaying readings.

### Function

The equipment monitors steam traps using ultrasonic and temperature measurements by a piezo element. These measurements are performed automatically at regular intervals.

The measured data is analysed in the MSBN... LoRa node and transferred to the LoRa gateway (accessory). The data is transferred by LoRa wireless technology via network protocol.

The measurement results are analysed on the basis of the sound and temperature values and parameters of the steam trap under test.

## Storing and transporting the equipment

### Storing the equipment

- Please observe the following items when storing the equipment:
- The equipment and all assemblies must be protected against jolts and impacts.
- Only store the equipment in enclosed spaces.
- Make sure the conditions in the Technical Data on page 21 ff. are complied with.
- Make sure that all these requirements are always met when storing the equipment.
- Please contact the manufacturer if you cannot comply with the recommended storage conditions.

### Transporting the equipment

- Meet the requirements for storage also when transporting the equipment.
- For transport, adhere to the conditions in the technical data on page 21.
- When transporting the equipment to the location of use, make sure it is secured against falling and impacts.



#### **DANGER**

Risk of fire due to the equipment's lithium metal batteries if the equipment is not transported correctly.

- When transporting the equipment, pay attention to the international rules on the transport of hazardous goods.
- When transporting the equipment, pay attention to the international rules on the transport of lithium metal batteries.

## Mounting and connecting the equipment

### Preparing installation

- Take the equipment out of the transport packaging.
- Check the equipment for transport damage.
- Contact the manufacturer if you detect any kind of shipping damage.



#### **DANGER**

Personnel working on pipes are exposed to safety risks and may suffer severe injuries, poisoning or even loss of life.

- Make sure that no hot or hazardous fluid is in the equipment or the pipes.
- Make sure that the pipes upstream and downstream of the equipment are depressurised.
- Make sure that the installation is switched off and protected against unauthorised or unintended activation.
- Make sure that the equipment and the pipes have cooled down to room temperatures.
- Wear protective clothing that is suitable for the fluid and, if necessary, wear protective gear.

For more information on suitable protective clothing and safety gear refer to the safety data sheet of the fluid in question.

- Make sure that there is no potentially explosive atmosphere at the installation site.



#### **WARNING**

Risk of electric shock when working on a pipe that is live.

- Before starting work, take suitable measures to ensure that no parts of the pipe are live.
- Only install the equipment on earthed pipes or steam traps.



- Drain pipes until they are empty.
- Switch the installation off and protect it against unauthorised or unintended re-activation.

You will need the following tools to install and connect the equipment:

- ◆ Combination spanner size 16
  - ◆ Combination spanner size 17
  - ◆ Torque wrench size 10 2.5–25 Nm
  - ◆ Torque wrench size 16 2.5–25 Nm
  - ◆ Torque wrench size 17 2.5–25 Nm
  - ◆ Phillips PH2 screwdriver
- Make sure the required tools are to hand.

## Mounting the equipment

---



### DANGER

Incorrectly connected equipment can cause fatal accidents or severe injuries.

- Make sure that only qualified skilled personnel connect the equipment to pipes.

---

Specialist personnel must be highly qualified and fully experienced in making pipe connections for the respective type of end connection.

---



### CAUTION

There is a risk of injury from sharp edges of fastening materials.

- Wear suitable protective clothing, especially sturdy gloves, during installation.

---

### ***Attention!***

The fastenings of vibrating plant parts may become detached if improperly fastened.

- Use threadlocker (e.g. Loctite) to secure the pre-amplifier and LoRa Node to vibrating plant parts.

- 
- Make sure that the pipe system of the plant is clean.

You can install the equipment sensor in the following locations (see accessories):

- ◆ In a pressure-bearing screw (PBS), in place of a cover screw of the steam trap
- ◆ Fastened to the pipe in the RFC clip

## Fitting the sensor to the steam trap



### DANGER

A loose pressure-bearing screw can lead to accidents resulting in very serious injury or death.

- Make sure that pressure-bearing screws do not come loose during installation and connection.

The sensor with pressure-bearing screw (PBS) is attached to the outlet side of the thermostatic steam trap in place of the cover screw.

- Undo both cover screws on the steam trap (7).
- Remove the cover screw (8) on the outlet side.
- Check that the gasket is in perfect condition.
- Coat the thread and contact surfaces with temperature-resistant lubricant.

The lubricant must have the same properties as OKS 217.

- Replace the gasket if necessary, as described in the steam trap Installation & Operating Manual.
- Insert the pressure-bearing screw (6) in the thread.
- Alternately tighten the cover screw and pressure-bearing screw to a torque of 25 Nm.
- With your hand, screw the MSBS... sensor (1) into the pressure-bearing screw (6).
- Tighten the MSBS... sensor to a torque of 2.5 Nm.

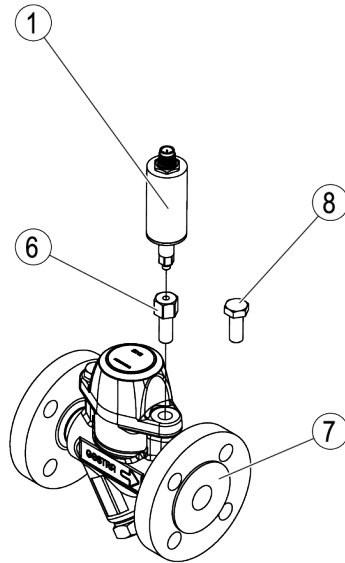

## Mounting the sensor in the RFC clip

Mount the MSBS... sensor (1) on the pipe using an RFC clip. Clips in various sizes are available as accessories. The adapter (12) is supplied with a clip for fastening it.

The location of the sensor on the pipe must meet the following conditions:

- ▶ The sensor must be upstream of the test object.
- ▶ The distance between the sensor and the test object must not exceed 200 mm.
- ▶ Do not fit the sensor to an insulated section of pipe.
- ▶ Push the screw (10) through the hole in the clip (11).
- ▶ Mount the clip (11) on the pipe in a suitable location.
- ▶ Tighten the screw (10) of the clip to a torque of 2.5 Nm.
- ▶ Screw the adapter (12) into the thread of the clip.
- ▶ Tighten the adapter (12) to a torque of 2.5 Nm.
- ▶ Screw the MSBS... sensor (1) into the thread of the adapter (12).
- ▶ Tighten the sensor to a torque of 2.5 Nm.

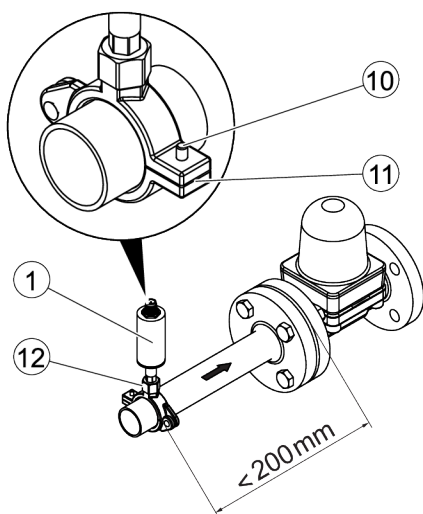

## Installing the MSBA... pre-amplifier and MSBN... LoRa Node

### Attention!

Incorrect installation can cause damage to cables or incorrect readings.

- Secure the MSBA... pre-amplifier (5) and MSBN... LoRa node (3) in a location with a maximum temperature of 50 °C.
  - Secure the MSBA... pre-amplifier (5) and MSBN... LoRa node (3) in such a way that the cable can be connected without strain.
- 
- Connect the connecting cable (4) of the MSBN... LoRa node (3) to the socket of the MSBA... pre-amplifier (5) without strain.

- Secure the MSBA... pre-amplifier (5) and MSBN... LoRa node (3) in a suitable location.

This could be a suitable insulated pipe, a wall, a mounting panel or a mounting system (accessory), for example, at a sufficient distance from the heat source.



We recommend installing the MSBA... pre-amplifier and MSBN... LoRa node on the mounting system (accessory) (see assembly drawing in Installation & Operating Manual BAN 809210).

- Connect the connecting cable (2) of the MSBA... pre-amplifier (5) to the MSBS... sensor (1) without strain.
- Tighten the threaded connection by hand (to approximately 0.6 Nm).

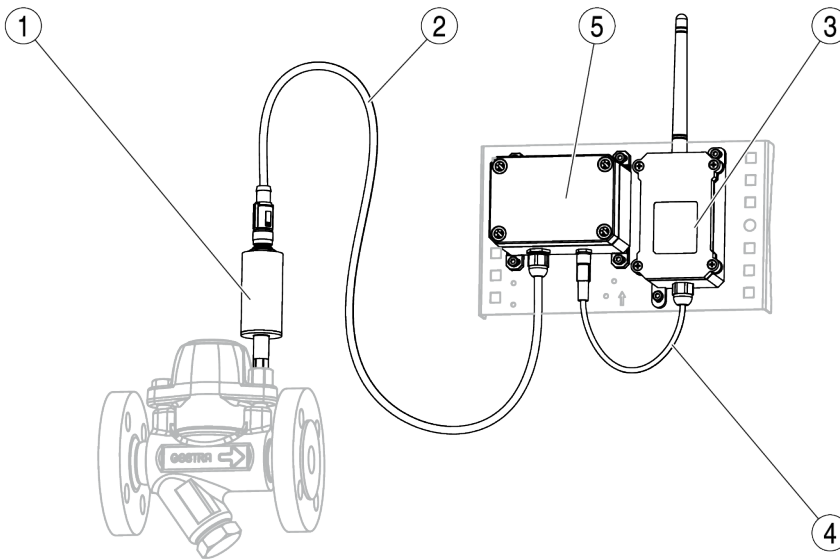

## Starting up the equipment

- Make sure that a configured LoRa gateway is available.

You can find information on the LoRa gateway (accessory) in the manufacturer's instruction manual supplied with the product.

### Registering the equipment with the LoRa network server

To register the LoRa node with a LoRa network server (LNS), you need the following LoRa keys:

- ▶ DevEUI: 16 hex digits (e.g. 0123456789ABCDEF)
- ▶ AppEUI: 16 hex digits (e.g. 0123456789ABCDEF)
- ▶ AppKEY: 32 hex digits (e.g. 0123456789ABCDEF0123456789ABCDEF).

These LoRa keys are provided with the equipment.

After you have successfully registered the MSBN-1C LoRa node with the LNS, the MSBN-1C LoRa node will be able to receive LoRa messages.

For this to happen, LoRa gateways must be near the MSBN-1C LoRa node and connected to the LNS.

### Switching on the equipment

Switch on the MSBN-1C LoRa node by setting the jumper on the PCB.

- Switch on the LoRa node as described in the manufacturer's Installation & Operating Manual.

Once it is switched on, the MSBN-1C LoRa node joins the LoRa network via the LoRa gateways and logs onto the LoRa network for the first time.

After successfully login to the LNS via over-the-air activation (OTAA), the LED of the pre-amplifier lights up.

## Operation

You cannot perform work on the equipment during operation.

The readings are taken automatically at regular intervals. During data acquisition, the LED on the pre-amplifier lights up.

- To evaluate readings, contact your local sales partner.

## After operation



### WARNING

Risk of electric shock when working on a pipe that is live.

- Before starting work, take suitable measures to ensure that no parts of the pipe are live.
- Only perform work on earthed pipes.

## Switching the equipment off



### WARNING

Risk of burns from hot system components.

- Wear insulated and temperature-resistant protective gloves.

The LoRa node only needs to be switched off for taking out of service or in the event of a malfunction. The procedure is the same as switching on.

- To switch off a LoRa node, open the housing.
- Remove the jumper as described in the manufacturer's Installation & Operating Manual supplied with the product.

## Removing external dirt deposits

---

### ***Attention!***

If fluids penetrate the equipment it may get damaged.

- Make sure that fluids cannot get into the equipment.
  - Use only a slightly moistened cloth to clean the equipment.
- 

- To remove dirt deposits rinse the equipment with fresh water and wipe it with a clean, lint-free cloth.
- To remove any persistent residues use a cleaning agent that is suitable for the material and carefully wipe the equipment with a clean, lint-free cloth.

## Maintaining the equipment

The equipment does not require any particular maintenance.

## Checking the component parts for damage

- Check that all equipment assemblies are in perfect condition before and after use.
- Do not bring damaged assemblies into service.
- Replace damaged assemblies.

## Servicing the equipment and installing spare parts

If an assembly is defective, it must be replaced.

- Register replaced assemblies with the network.
- Replace components only with genuine spare parts from the manufacturer.

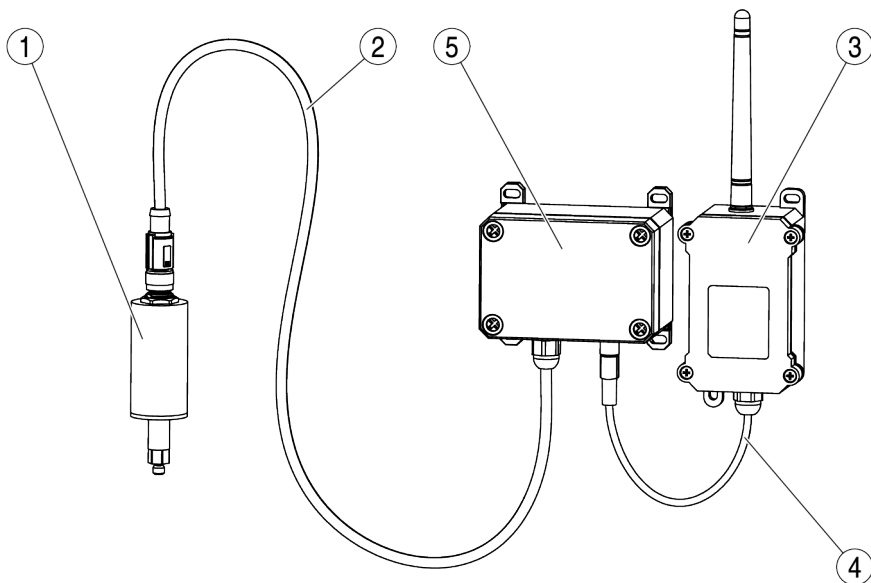

### Spare parts for the MSB-1C, MSB-1.2C

No.	Designation	Stock code	
		MSB-1C	MSB-1.2C
1	MSBS-1 sensor	442261	
2, 5	MSBA... pre-amplifier with connecting cable	442298	442299
3, 4	MSBN-1C EU/UK LoRa node with connecting cable	442335	

For further spare part stock codes of versions for specific countries, see Installation & Operating Manual BAN 851072.

## Troubleshooting

<b>Problem</b>	<b>Cause</b>	<b>Action</b>
Cannot log in to the LoRa network server.	Login credentials not available.	Contact your local sales partner.
	Wrong login credentials entered.	Check entered values: DevEUI: 16 hex digits AppEUI: 16 hex digits AppKEY: 32 hex digits
LoRa node cannot be switched on.	The battery is empty.	Contact your local sales partner.
	Repeat the switch-on sequence.	MSBN-1C: Check the jumper.
LoRa node does not send any data.	LoRa node is not registered.	Set up the LoRa node again and register it.
	The battery is empty.	Contact your local sales partner.
	Poor reception of transferred data.	Change the installation location of the LoRa node or the gateway. Make sure the supplied antenna is mounted correctly.
	Firewall prevents the gateway from communicating with the network server (only if using Ethernet/Wi-Fi).	Check your firewall settings.
	Gateway has no mobile phone coverage (only if using GSM/LTE).	Insert a SIM card and have it activated by the network operator. Make sure the gateway has mobile network coverage and is correctly positioned.
LoRa node only sends data sporadically (not hourly).	LoRa wireless coverage insufficient.	Check the spreading factor and change the installation position of the LoRa node or gateway if necessary. Make sure the supplied antenna is mounted correctly.  If just individual data packages are missing (e.g. one per week), this is not an error.  If necessary, enable and configure the "Confirmed Messaging" function. This will lead to increased battery usage, however.



<b>Problem</b>	<b>Cause</b>	<b>Action</b>
LoRa node sends implausible data.	Pre-amplifier or sensor is not connected.	Compare data with a reference measurement using a VKP.  Make sure the LoRa node, pre-amplifier, sensor and measuring point are correctly connected.  Contact the manufacturer.  Replace equipment assemblies if necessary.
LoRa node issues an ambient temperature warning or ambient temperature error.	Ambient temperature is too high or too low.	Check the ambient temperature.  If necessary, choose a different position for the LoRa node.
LoRa node issues a temperature warning or temperature error.	Pre-amplifier or sensor is not connected.	Ensure the LoRa node, pre-amplifier and sensor are correctly connected.
	Sensor open circuit or short circuit.	Check the wiring between the LoRa node, pre-amplifier and sensor.
LoRa node issues a battery warning or battery error.	The battery is empty.	Contact your local sales partner.
LoRa node issues a piezo warning or piezo error.	Pre-amplifier or sensor is not connected.	Ensure the LoRa node, pre-amplifier and sensor are correctly connected.
QR codes cannot be read.	Wrong distance or poor lighting.	Adjust the lighting or distance or use a magnifying glass.
"Live steam leakage" is shown continuously, even though the steam trap is intact.	Wrong equipment version (MSB-1C or MSB-1.2C) selected.	Use a different equipment version.
"Steam trap OK" is displayed even though the steam trap is faulty.	Wrong equipment version (MSB-1C or MSB-1.2C) selected.	Use a different equipment version.

- If you are unable to remedy the problem with the help of these instructions, please contact the manufacturer, GESTRA.

## Putting the equipment out of operation

The LoRa node only needs to be switched off for taking out of service or in the event of a malfunction. The procedure is the same as switching on.

- To switch off a LoRa node, open the housing.
- Remove the jumper as described in the manufacturer's Installation & Operating Manual supplied with the product.



### WARNING

Risk of electric shock when working on a pipe that is live.

- Before starting work, take suitable measures to ensure that no parts of the pipe are live.
- Only perform work on earthed pipes.

## Removing the equipment



### DANGER

Personnel working on pipes are exposed to safety risks and may suffer severe injuries, poisoning or even loss of life.

- Make sure that no hot or hazardous fluid is in the equipment or the pipes.
- Make sure that the pipes upstream and downstream of the equipment are depressurised.
- Make sure that the installation is switched off and protected against unauthorised or unintended activation.
- Make sure that the equipment and the pipes have cooled down to room temperatures.
- Wear protective clothing that is suitable for the fluid and, if necessary, wear protective gear.

For more information on suitable protective clothing and safety gear refer to the safety data sheet of the fluid in question.

- Remove the sensor in reverse order to steam trap installation.
- If necessary, fit the screw to the cover of the steam trap, as described in the steam trap Installation & Operating Manual.
- Install the LoRa node in reverse order to installation.
- Detach the connecting cable from the sensor and the LoRa node.
- Store the equipment as described on page 8.

## Returning the equipment

You can return the equipment to your contractual partner.

- Make sure that all harmful substances are removed from the equipment.
- Pay attention to the instructions in section "Transporting the equipment" from page 8.
- Pack the equipment in its original packaging or in suitable transport packaging.

The transport packaging must protect the equipment from damage in the same way as the original packaging.

- Send the completed and signed declaration of decontamination with the equipment. The declaration of decontamination must be attached to the packaging so that it is accessible from the outside.
- Register the return delivery with your contractual partner before returning the equipment.

## Disposing of the equipment

---



### CAUTION

Environmental damage may be caused by poisonous fluid residues.

- Before disposing of the equipment make sure that it is clean and free of fluid residues.
  - For the disposal of all materials observe the pertinent legal regulations concerning waste disposal.
- 

The equipment is made from the following materials:

<b>Component</b>	<b>Material</b>
Housing of MSBS-1 sensor	1.4305
Housing of MSBA-1C, MSBA-1.2C pre-amplifier	Polycarbonate GF10
MSBN-1C LoRa node	See LoRa node documentation
Battery	Lithium metal battery (Li-SOCl <sub>2</sub> )



You can find information on the materials of the assemblies in the supplied manufacturer's documentation.

The equipment and its assemblies contain electronic parts.

## Technical data

### Dimensions and weights

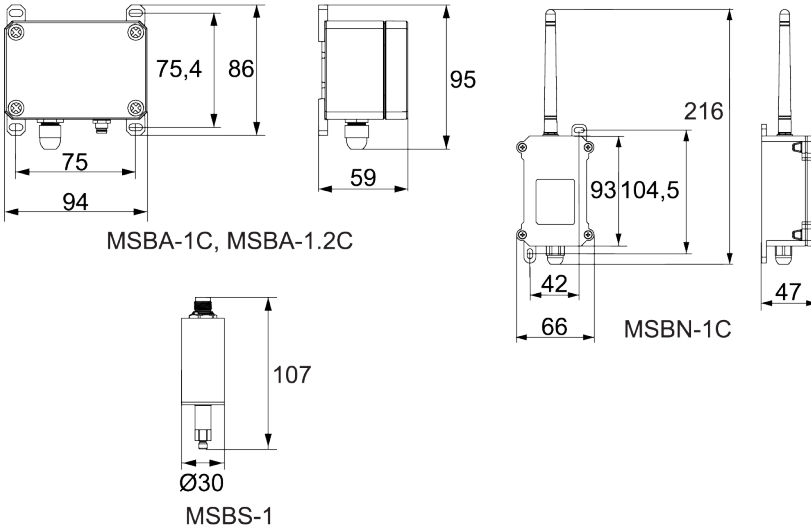

Dimensions mm

Assembly	Dimensions mm			Weight g
	Length/height t	Width/ diameter	Depth	
MSBS-1 sensor	107	30	–	160
MSBA-1C, MSBA-1.2C pre-amplifier	86	94	59	210 <sup>1</sup>
Sensor connecting cable	1,000	–	–	–
Pre-amplifier connecting cable	200	–	–	–
MSBN-1C LoRa node	216	66	47	200 <sup>1</sup>

1 With connecting cable

## Electrical data

Assembly	Supply voltage	Protection class	Overtoltage category
MSBS-1 sensor	–	III (SELV)	I
MSBN-1C LoRa node	3.6 V		
MSBA-1C or MSBA-1.2C pre-amplifier	5.0 V / 5 mA		

Battery life with one measurement per hour: approx. 10 years in ideal conditions (SF7, constant ambient temperature of 20 °C)

Assembly	Wireless device class	Maximum output power	Frequency range	Detection range
MSBN-1C EU/UK	LoRaWAN Class A	+14 dBm / 25 mW	LoRaWAN network protocol 863–870 MHz	Depending on installation location and gateway position. (Up to 3 km in urban areas, up to 10 km in rural areas)

For further versions for specific countries, see Installation & Operating Manual BAN 851072.

## Ambient conditions

Area of application	Indoors and outdoors
Maximum altitude	2,000 m
Protection against ingress of foreign bodies	Suitable for industrial use
Pollution degree	4
Admissible ambient temperature	–20 — 50 °C

## Pressure & temperature ratings

### MSB-1C, MSB-1.2C

Assembly	Storage/ operating temperature °C	IP rating
MSBS-1 sensor	–20 — 50	IP64
MSBA-1C, MSBA-1.2C pre-amplifier		IP66
MSBN-1C LoRa node		IP68

- The temperature of the fluid in the steam trap must not exceed 240 °C.

## Declaration of Conformity – Standards and Directives

You can find details on the conformity of the equipment and the applicable standards and directives in the Declaration of Conformity and the relevant certificates.

You can download the latest Declaration of Conformity at [www.gestra.com](http://www.gestra.com). You can request the relevant certificates by writing to the following address:

### **GESTRA AG**

Münchener Straße 77

28215 Bremen

Germany

Phone +49 421 3503-0

Fax +49 421 3503-393

e-mail [info@de.gestra.com](mailto:info@de.gestra.com)

Web [www.gestra.com](http://www.gestra.com)

Modifications to the equipment not approved by us will invalidate the Declaration of Conformity and the certificates.





You can find our authorized agents around the world at: [www.gestra.com](http://www.gestra.com)

**GESTRA AG**

Münchener Strasse 77  
28215 Bremen  
Germany

Phone +49 421 3503-0  
Fax +49 421 3503-393  
e-mail [info@de.gestra.com](mailto:info@de.gestra.com)  
Web [www.gestra.com](http://www.gestra.com)

**UK Importer**

GESTRA UK Ltd

Unit 1 Sopwith Park, Royce Close,  
West Portway Business Park, Andover,  
Hampshire SP10 3TS  
United Kingdom

851089-00/09-2024 kx\_mm (809240-00) © GESTRA AG Bremen Printed in Germany