



Level Electrode

NRG 26-61

EN
English

Installation & Operating Manual
819874-01

Contents

Content of this Manual	4
Scope of delivery/Product package	4
How to use this Manual	5
Illustrations and symbols used	5
Hazard symbols in this Manual	5
Types of warning	6
Specialist terms/Abbreviations	7
Usage for the intended purpose	8
Admissible system components, dependent on the required safety integrity level	9
Improper use	9
Basic safety notes	10
Required personnel qualifications	11
Notes on product liability	11
Functional safety, safety integrity level (SIL)	12
Check the safety function regularly	12
Reliability data to IEC 61508	13
Function	14
Technical data	17
Example name plate/Identification	19
Factory settings	20
Overall view of the NRG 26-61	21
Dimensions of the NRG 26-61	22
Preparing for installation	23
Installation	24
Sealing surface dimensions for NRG 26-61	25
Example	25
Installing two level electrodes in a flange by detaching a terminal box	26
Installation examples with dimensions	29
Aligning the terminal box	34
Functional elements	35
Connecting the CAN bus system	36
Bus line, cable length and cross-section	36
Example	36
Important notes on connecting the CAN bus system.....	37
Pin assignment of the CAN bus connector and coupling for non pre-wired control cables.....	37

Contents

Bringing into service	38
Changing the factory settings if necessary	38
Changing parameters with password protection enabled	38
Notes on changing communication parameters “bd.rt, Id.Lo; Id.Hi or GrP”	41
Changing the “Id.Lo / Id.Hi” limiter ID	41
Changing the controller group “GrP”	42
Changing the baud rate “bd.rt”	42
Setting the “AL.Lo” (low-level alarm = LW) limit	43
Setting the “AL.Hi” (high-level alarm = HW) limit	43
Calibrate the lower limit of the active measuring range “CAL.L” (0% calibration value)	44
Perform independent rapid calibration at a water level of > 25% of the active measuring range “CAL.P”	44
Calibrate the upper limit of the active measuring range “CAL.H” (100% calibration value)	45
Setting the filter constant “Filt”	45
Manually initiating a display test	45
Activating URB 2 compatibility “ConP”	46
Viewing the software version and equipment type “InFo”	46
Enabling/disabling password protection	47
Checking the LW and HW limiter switchpoints by raising or reducing the level	48
Checking the limiter switchpoints by initiating a test function	48
Lockout function	48
Starting, operation and testing	49
System malfunctions	53
Causes	53
Indication of system malfunctions using error codes	54
Common application and usage errors	56
Checking installation and function	58
Taking out of service/Disassembly	59
Cleaning the level electrode	60
Cleaning interval	60
Disposal	60
Returning decontaminated equipment	60
Declaration of Conformity; Standards and Directives	61

Content of this Manual

Product:

Level Electrode NRG 26-61

First edition:

BAN 819874-00/08-2019cm

© Copyright

All rights reserved. Any misuse, particularly reproduction and dissemination to third parties, is not permitted. The General Terms & Conditions of GESTRA AG apply.

Scope of delivery/Product package

- 1 x level electrode NRG 26-61
- 1 x sealing ring D 27 x 32, form D, DIN 7603-2.4068, bright annealed
- 1 x Installation & Operating Manual

Accessories

- 1 x M12 CAN bus connector, 5-pole, A-coded, with 120 Ω terminating resistor

How to use this Manual

This Installation & Operating Manual describes the correct use of the NRG 26-61 level electrode. It applies to all persons who integrate this equipment into control systems, install, bring into service, operate, maintain and dispose of this equipment. Anyone carrying out the above-mentioned activities must have read this Installation & Operating Manual and understood its contents.

- Read this Manual in full and follow all instructions given.
- Please also read the instructions for use of any accessories.
- The Installation & Operating Manual is part of the product package. Keep it in an easily accessible location.

Availability of this Installation & Operating Manual

- Make sure that the Installation & Operating Manual is always available to the operator.
- If you pass on or sell the equipment to a third party, please also hand over the Installation & Operating Manual.

Illustrations and symbols used

1. Action to be taken
- 2.

- Lists
 - ◆ Bullet points in lists

A Keys to illustrations



Additional information



Read the relevant Installation & Operating Manual



Press the rotary knob

Hazard symbols in this Manual



Danger zone / Dangerous situation



Danger of death from electric shock

Types of warning

DANGER

Warning of a dangerous situation that will result in death or serious injury.

WARNING

Warning of a dangerous situation that may possibly result in death or serious injury.

CAUTION

Warning of a situation that may result in minor or moderate injury.

ATTENTION

Warning of a situation that will result in damage to property or the environment.

Specialist terms/Abbreviations

Here, we explain some abbreviations, specialist terms, etc., which are used in this Manual.

IEC 61508

International standard IEC 61508 describes both the type of risk assessment and actions taken to provide appropriate safety functions.

SIL (safety integrity level)

Safety integrity levels SIL 1 to 4 are used to quantify risk reduction. SIL 4 is the highest level of risk reduction. International standard IEC 61508 forms the basis for establishing, testing and operating technical safety systems.

CAN (Controller Area Network) bus

Data transmission standard and interface for connecting electronic equipment, sensors and control systems. Data can be sent and received.

NRG .. / URS .. / URB .. / SRL .. / etc.

Equipment and type designations of GESTRA AG, see page 9.

SELV

Safety Extra Low Voltage

Operating point (of the plant)

The operating point describes the operating parameters within which a plant or boiler is operated in its nominal range. In a steam boiler, for example, these parameters would be pressure and temperature.

The pressure at the operating point does not have to match the design pressure, but is the same or lower.

Usage for the intended purpose

Use as a safety high-level (HW) limiter and low-level (LW) limiter

The NRG 26-61 level electrode is used in conjunction with the URS 60/URS 61 safety control unit as a safety high-level limiter and low-level limiter for steam boilers and hot water installations.

- Safety high-level limiters prevent the defined maximum high water (HW) level from being exceeded, e.g. by switching off the feedwater supply.
- Low-level limiters switch off the heating when the water drops below the set minimum level (LW).



Safety notes for use as an LW limiter

- Since the electrode works on the principle of continuous capacitive measurement, the low-level limiter function of the NRG 26-61 may only be used in combination with a conductive NRG 16-60 level electrode.
 - Always use the NRG 16-60 level electrode as the first low-level electrode.
-

Additional use as a level control system

The NRG 26-61 level electrode can also be used in combination with an NRR 2-60/NRR 2-61 level controller to continuously measure the water level in steam boiler and hot water installations or in condensate and feedwater tanks.

- In combination with the NRR 2-60/NRR 2-61 level controller, the electrode can be used as a level control system with MIN/MAX alarm, for example.
- The limiter functions can be disabled independently from one another and from the infinitely variable measurement signal.

Influence of the fluid to be monitored

- The NRG 26-61 level electrode can be used in fluids with different conductivity. However, a conductivity of less than 100 $\mu\text{S}/\text{cm}$ has a major influence on the measured capacitance, which is why it is extremely important to recalibrate the measuring range at the operating point* when bringing into service.

* *Operating point of the plant, see page 7.*

- To achieve the best possible reproducibility and maintain high-quality measurements (see “Technical data” on page 17), the sensor must be installed in a protective tube (see “Installation examples with dimensions” on page 29 ff.).
- This is the only way to ensure safe use as a level limiter with a SIL 2 rating at the stated values.
- The dielectric constant of the monitored fluid may require an adjustment to the measurement frequency if it deviates significantly from the usual water ($\epsilon_r = 80$). For this, please contact the GESTRA AG Service department.

Visual display and operation

- Viewing and operation take place using the URB 60 or SPECTORcontrol operating terminal.

Usage for the intended purpose

Admissible system components, dependent on the required safety integrity level

The level electrode can be operated with the following system components:

	Level control and limiter electrode	Safety control unit for limiters	Control unit as level controller and limit indicator	Operating unit
SIL 2 to IEC 61508	NRG 26-61	URS 60 URS 61	–	URB 60, SPECTOR <i>control</i>
Without SIL as per IEC 61508	NRG 26-61	–	NRR 2-60 NRR 2-61	URB 60, SPECTOR <i>control</i>

Fig. 1

Key to Fig. 1:

NRG = level electrode

URS = SPECTOR*connect* safety control unit

URB = visual display and operating unit

SRL = monitoring unit

NRR = level controller, continuous



To ensure the proper use of equipment during all types of use, please also read the Installation & Operating Manuals for the system components used.

- You will find the latest Installation & Operating Manuals for the system components named in Fig. 1 on our website:
www.gestra.com

Improper use



There is a danger of death due to explosion if the equipment is used in potentially explosive atmospheres.

Do not use the equipment in potentially explosive atmospheres.



Do not bring any equipment into service that does not have its own specific name plate.

The name plate indicates the technical features of the equipment.

Basic safety notes



Danger to life from scalding if the level electrode is removed under pressure. Steam or hot water can spurt forcefully out of the equipment.

- Only remove the level electrode at a **boiler pressure of 0 bar**.



Risk of severe burns if work is performed on a level electrode that has not been allowed to cool. The level electrode becomes very hot during operation.

- Always allow the level electrode to cool.
- Perform all installation and maintenance work only when the level electrode has been allowed to cool.



There is a risk of electric shock during work on electrical systems.

- Always switch off the voltage to the plant before performing connection work.
- Check that the plant is not carrying live voltage before commencing work.



Danger to life from a faulty NRG 26-61 level electrode due to the sudden escape of hot steam or hot water.

Shocks and impacts during transport or installation can result in damage to or leaks in the NRG 26-61 level electrode, causing pressurised hot steam or hot water to escape through the pressure relief hole.

- To prevent damage during transport and installation, do not expose the electrode rod to major jolts or impacts.
- Before and after installation, check that the level electrode is completely undamaged.
- Check that the level electrode is not leaking when bringing into service.



Attempts to repair the equipment will cause the plant to become unsafe.

- The NRG 26-61 level electrode may only be repaired by the manufacturer, GESTRA AG.
- Only replace faulty equipment with identical equipment from GESTRA AG.

Required personnel qualifications

Activity	Personnel	
Integration in control system	Specialist staff	Plant designer
Installation/electrical connection/ bringing into service	Specialist staff	The unit is an item of equipment with a safety function (EU Pressure Equipment Directive) and may only be installed, electrically connected and brought into service by suitable, trained staff.
Company	Boiler service technician	Staff trained by the plant operator.
Maintenance work	Specialist staff	Maintenance and refits may only be performed by authorised staff who have undergone specific training.
Refits	Specialist staff	Persons trained by the plant operator to work with pressure and temperature.

Fig. 2

Notes on product liability

We the manufacturer cannot accept any liability for damages resulting from improper use of the equipment.

Functional safety, safety integrity level (SIL)

In combination with the URS 60/URS 61 safety control unit, the NRG 26-61 level electrode is suitable for safety functions up to SIL 2.

It is an element of a safety circuit up to SIL 2 as per IEC 61508 in the SPECTOR*connect* system, and can transmit alarm notifications.

When combined with the accessories, you will have a type B subsystem. The technical and safety characteristics in Fig. 4 are based solely on the NRG 26-61 level electrode.

Breakdown of safety function failure rates (safety shutdown)

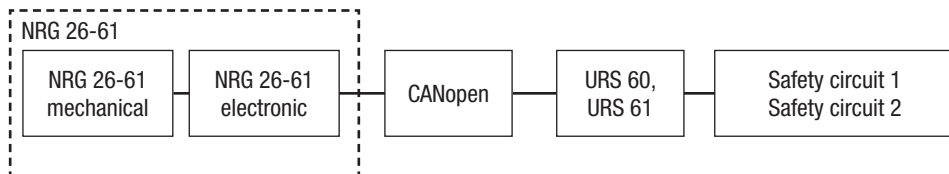

Fig. 3

The CANopen interface is a “black channel” type, and can be ignored during calculation due to the low failure rate of < 1FIT.

Check the safety function regularly

Check the limiter function of the level electrode at least once a year by bringing the water to the minimum and/or maximum level ($T_1 = 1$ year), see page 48.

The test function is initiated on site using the rotary knob integrated in the terminal box, see page 52.

In addition, the test function can be initiated remotely on the URS 60/URS 61 or the external URB 60 or SPECTOR*control* operating units.

Reliability data to IEC 61508

Description	Characteristic values
Safety integrity level	SIL 2
Architecture	1oo1
Type of equipment	Type B
Hardware fault tolerance	HFT = 0
Overall failure rate for dangerous undetected failures	$\lambda_{DU} = < 20 * 10^{-9} \text{ 1/h}$
Overall failure rate for dangerous detected failures	$\lambda_{DD} = < 2000 * 10^{-9} \text{ 1/h}$
Safe failure fraction	SFF > 99.0%
Test interval	T1 = 1 year
Probability of dangerous failure on demand	PFDD < $100 * 10^{-6}$
Diagnostic coverage. Percentage of dangerous failures detected by a test.	DC > 98.0%
Mean time to dangerous failure	MTTF _D > 30 a
Mean time to failure	MTTF > 10 a
Diagnostic interval	T2 = 1 hour
Performance level (to ISO 13849)	PL = d
Probability of dangerous failure on demand per hour	PFH < $20 * 10^{-9} \text{ 1/h}$
Ambient temperature as a basis for calculation	T _u = 60 °C
Mean time to repair	MTTR = 0 (no repair)
Fraction of undetected dangerous failures that have a common cause	beta = 2%
Fraction of detected dangerous failures that have a common cause	beta d = 1%

Fig. 4

Function

The NRG 26-61 level electrode works using the capacitance measurement principle and converts the water level information into a data telegram. The 0-100% measuring range can be scaled by modifying the effective length of the electrode rod.

Automatic self-test

An automatic self-test cyclically monitors the safety and function of the level electrode and measured value acquisition.

The data are transferred to the URS 60/URS 61 safety control unit in the form of a black channel data telegram in the CANopen protocol via an ISO 11898 CAN bus.

These data telegrams contain the following information:

- Level reading as raw data
- Level reading scaled between 0-100% as a 16-bit data word in high resolution
- Level reading scaled in 1% increments without decimal places
- Limiter LW/HW alarm limits
- Status or error information
 - ◆ Fault indications on the occurrence of faults in electronic or mechanical parts
 - ◆ Temperature in the level electrode terminal box
- LW/HW limiter test command

Limiter functions

If the water exceeds the set high-level point, the URS 60 or URS 61 safety control unit initiates a safety shutdown. This “High Water (HW)” switchpoint is adjusted solely using the rotary knob on the NRG 26-61 level electrode.

If the water falls below the set low-level point, the URS 60 or URS 61 safety control unit initiates a safety shutdown. This “Low Water (LW)” switchpoint can be adjusted solely using the rotary knob on the NRG 26-61 level electrode.

The level electrode works using the capacitance measurement principle and is equipped with numerous self-monitoring mechanisms. Faults in the electrical connection or electronic measuring equipment trigger fault indications and safety shutdowns.

The level electrode is installed on the inside of steam boilers, tanks and feed lines in hot water installations. A protective tube provided on site keeps it functioning reliably (see page 29 “Installation examples”).

A capacitance NRG 26-61 level electrode and a conductive NRG 1x-60 or NRG 1x-61 level electrode can be installed in the same protective tube or level pot.



Safety notes for use as an LW limiter

- Since the electrode works on the principle of continuous capacitive measurement, the low-level limiter function of the NRG 26-61 may only be used in combination with a conductive NRG 16-60 level electrode.
 - Always use the NRG 16-60 level electrode as the first low-level electrode.
-

Function

Use as a limiter in externally mounted level pots

If a level electrode is installed outside the boiler in a level pot that can be shut off, the connecting pipes must be flushed regularly. An SRL 6-60 monitoring unit is additionally required to monitor the flushing times and flushing process.

If the steam pipe is ≥ 40 mm and the water pipe is ≥ 100 mm, installation is regarded as internal. In this case, upstream monitoring of flushing processes is not required.

Indications and signals, see page 49 / 53 *

The NRG 26-61 level electrode has a green 4-digit, 7-segment display for showing readings, status information and error codes. The operating status is indicated by a red and green LED.

Behaviour when switched on *

“**LO.LE**” and “**HI.LE**” (low and high-level alarm, LW and HW) are shown alternately on the display.



These are at the factory-set alarm limits “AL.Lo” and “AL.Hi”.

When bringing into service for the first time, you will therefore be asked to change the alarm limits to suitable values for your specific plant.

To set the “**AL.Lo**” and “**AL.Hi**” alarm limits, see page 43.

Behaviour in normal operation (no alarm, no faults) *

The display shows the scaled level reading (3 digits + 1 decimal place), e.g. 050.3



The scale of the 0-100% measuring range is factory-set to maximum for the electrode length used.

Adjusting the measuring range when bringing into service (CAL.L, CAL.P or CAL.H)

Adjust the measuring range in line with the sight glass when bringing into service, using the parameters CAL.L, CAL.P or CAL.H, see page 44 - 45. This is the only way to gain all the benefits of high-resolution readings in the sight glass range.



When the equipment is brought into service for the first time, the “**AL.Lo**” and “**AL.Hi**” alarm limits are set to Max/Min values, which is why the warning messages “**LO.LE**” and “**HI.LE**” are shown alternately on the display.

First, set the “**AL.Lo**” and “**AL.Hi**” alarm limits to suitable values for your specific plant, see page 43.

Function

Behaviour in the event of alarms (level is above or below the limit) *

“**LO.LE**” (for LW) or “**HI.LE**” (for HW) are shown on the display, alternating with the actual level value.

The alarm state is transferred to the URS 60 or URS 61 safety control unit via CAN data telegram. There, once the time delay has elapsed, the alarm signal triggers the safety shutdown in the safety control unit. The URS 60/URS 61 safety control unit does **not** automatically lock the safety contacts.

Behaviour in the event of malfunctions *

An error code, e.g. E.005, is shown continuously on the display. Error codes, see page 54.

The error state is transferred to the URS 60 or URS 61 safety control unit via CAN data telegram. The fault indication triggers an immediate safety shutdown there. The URS 60/URS 61 safety control unit does **not** automatically lock the safety contacts.



Electrode alarms and fault indications cannot be acknowledged.

When the alarm or fault indication is cancelled the display also goes blank, and the URS 60/URS 61 safety control unit closes the safety contacts once more.

Simulating the alarm state *

The triggering of an alarm can be simulated by pressing the rotary knob of the NRG 26-61, pressing the appropriate button on the URS 60/URS 61, or using the URB 60 operating unit. The equipment will then behave as if a normal alarm had been triggered.



* The tables on pages 50 - 52 clearly show the relationship between the equipment status, the display and the alarm LEDs.

Setting parameters and changing factory settings

If necessary, you can adapt the electrode parameters to suit conditions at the plant. You can set parameters and change factory settings using a rotary knob on the terminal box, see page 38 ff.

Controller functions

In addition, the NRG 26-61 level electrode can be used in conjunction with an NRR 2-60/NRR 2-61 level controller to form a level control system. The controller parameters are set solely on the URB 60 visual display and operating unit.

Technical data

Model and mechanical connection

- Thread G $\frac{3}{4}$ A, EN ISO 228-1, see Fig. 8

Nominal pressure rating, admissible service pressure and temperature

- PN 40 32 bar (abs) at 238 °C

Materials

- Terminal box: 3.2581 G AISi12, powder-coated
- Sheath: 1.4301 X5 CrNi 18-10
- Electrode rod insulation: PTFE
- Screw-in body: 1.4571, X6CrNiMoTi17-12-2

pH value

- Maximum admissible = 10

Max. installed length at 238 °C, all measurements in mm

Max. installed length:	373	477	583	688	794	899	1004
Measuring range:	300	400	500	600	700	800	900
Max. installed length:	1110	1214	1319	1423	1528	1636	2156
Measuring range:	1000	1100	1200	1300	1400	1500	2000



Do not shorten the electrode rod.

Measurement quality

The information below applies to a compensated fluid conductivity range from 0.5-10000 $\mu\text{S}/\text{cm}$ based on 25 °C.

- Reading error: +/- 1% from the set measuring range at the operating point
- Limit error: + 1% from MAX (AL.Hi)
- 1% from MIN (AL.Lo)
- MAX hysteresis: - 3% from limit value
- MIN hysteresis: + 3% from limit value
- Resolution of reading on display: 0.1%
- Resolution for internal processing: 15 bit
- Sensitivity (minimum conductivity)
 - ◆ Water $\geq 0.5 \mu\text{S}/\text{cm}$ (see page 8 "Influence of the fluid to be monitored")

Supply voltage

- 24 V DC +/-20%

Technical data

Power consumption

- Max. 7 W

Current input

- Max. 0.3 A

Internal fuse

- T2A

Safety cutout at excessive temperature

- Cutout occurs when an excessive temperature of 75 °C is measured in the electrode tip

Input/output

- Interface for CAN bus to ISO 11898, CANopen, isolated
- M12 CAN bus connector, 5-pole, A-coded
- M12 CAN bus socket, 5-pole, A-coded

Indicators and controls

- 1 x green 4-digit, 7-segment display for showing status information
- 1 x red LED for indicating an alarm
- 1 x green LED for indicating OK
- 1 x rotary knob IP65 with button for menu navigation and test function

Protection class

- III Safety Extra Low Voltage (SELV)

IP rating to EN 60529

- IP 65

Admissible ambient conditions

- Service temperature: 0 °C – 70 °C
- Storage temperature: -40 °C – 80 °C
- Transport temperature: -40 °C – 80 °C
- Air humidity: 10% – 95% non-condensing







Weight

- Approx. 2.1 kg

Admissible installation positions

- Vertical
- Oblique to a maximum inclination of 45°. In this case, the length of the electrode rod is limited to 688 mm maximum.

Example name plate/Identification

 Betriebsanleitung beachten! See installation instruction!	
 Vor dem Öffnen des Deckels Gerät freischalten! Before removing cover isolate from power supplies!	
1	
2	
3	
4	5 6 7
	bar (psi) 8 °C (°F) Tamb = T °C (°F)
9	10
L/H= 11	
ppm	µS/cm
12	
13	
14	
15 UK CA	EAC CE  16
17 GESTRA AG Münchener Str.77 28215 Bremen Made in Germany	 18
19  12345678-12345678	

- 1 Safety note
- 2 Equipment designation
- 3 Equipment function
- 4 Nominal pressure rating
- 5 Connection thread
- 6 Material of screw-in body
- 7 IP rating
- 8 Operating data (maximum pressure and temperature)
- 9 Supply voltage
- 10 Power consumption
- 11 Measuring range
- 12 Actual value output
- 13 Safety integrity level
- 14 Type-approval number
- 15 Conformity marking
- 16 Disposal information
- 17 Manufacturer
- 18 Protection class
- 19 Material number-serial number

Fig. 5



The date of production (quarter and year) is stamped on the screw-in body of each level electrode.

Factory settings

The NRG 26-61 level electrode is delivered ex-works with the following settings:

Parameter	Display in menu	Parameter values	Unit	
		NRG 26-61		
Limiter ID	Id.Lo	0002	---	
Limiter ID	Id.Hi	0005	---	
Controller group	GrP	0001	---	
Baud rate	bd.rt	0050	kbit/s	
Alarm limit	AL.Lo	100	%	
Alarm limit	AL.Hi	0	%	
Calibrate start of measuring range	CAL.L	variable	0%	Raw value (hex) approx. 50 mV on ADC
Calibrate measuring range section	CAL.P	variable	25%	Raw value (hex)
Calibrate end of measuring range	CAL.H	variable	100%	Raw value (hex) approx. 2.0 V on ADC
Filter constant	FiLt	0005	seconds	
Compatibility mode	ConP	oFF	---	
Password	PW	oFF	---	

Fig. 6

Overall view of the NRG 26-61

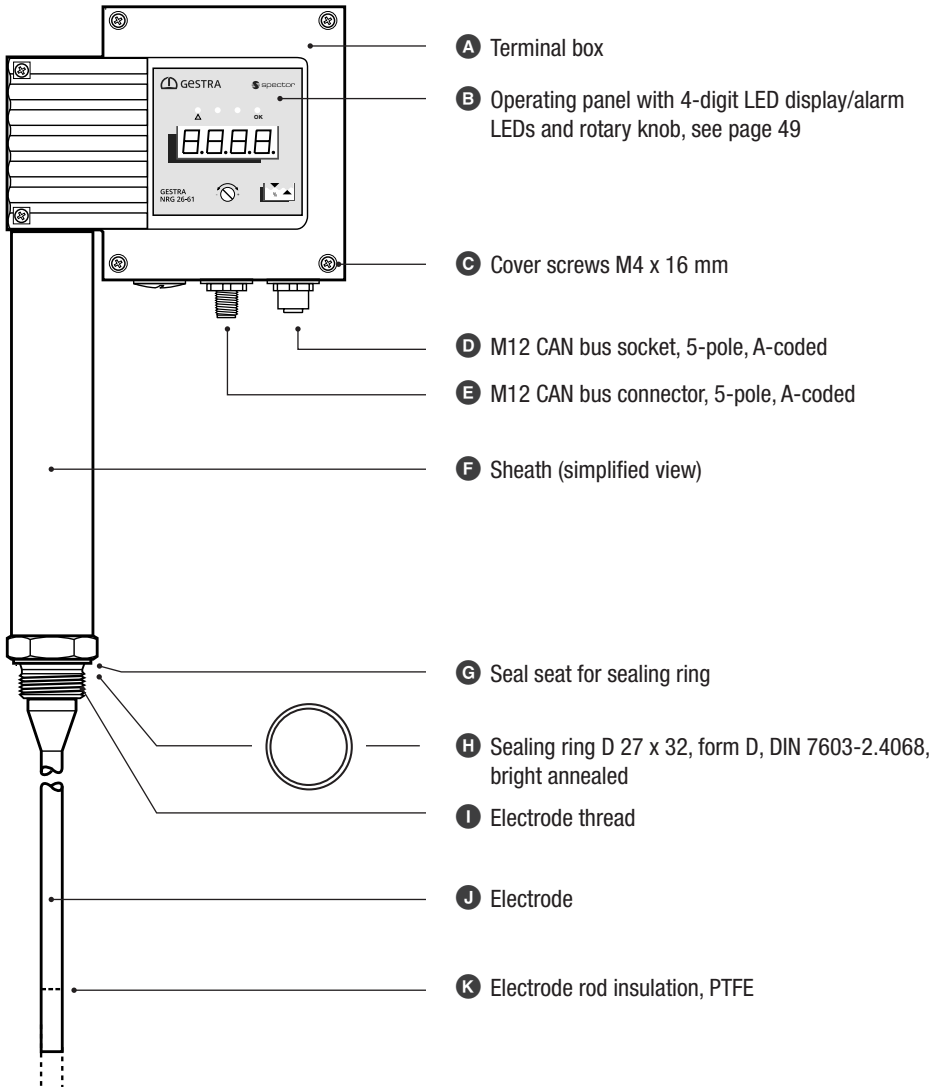
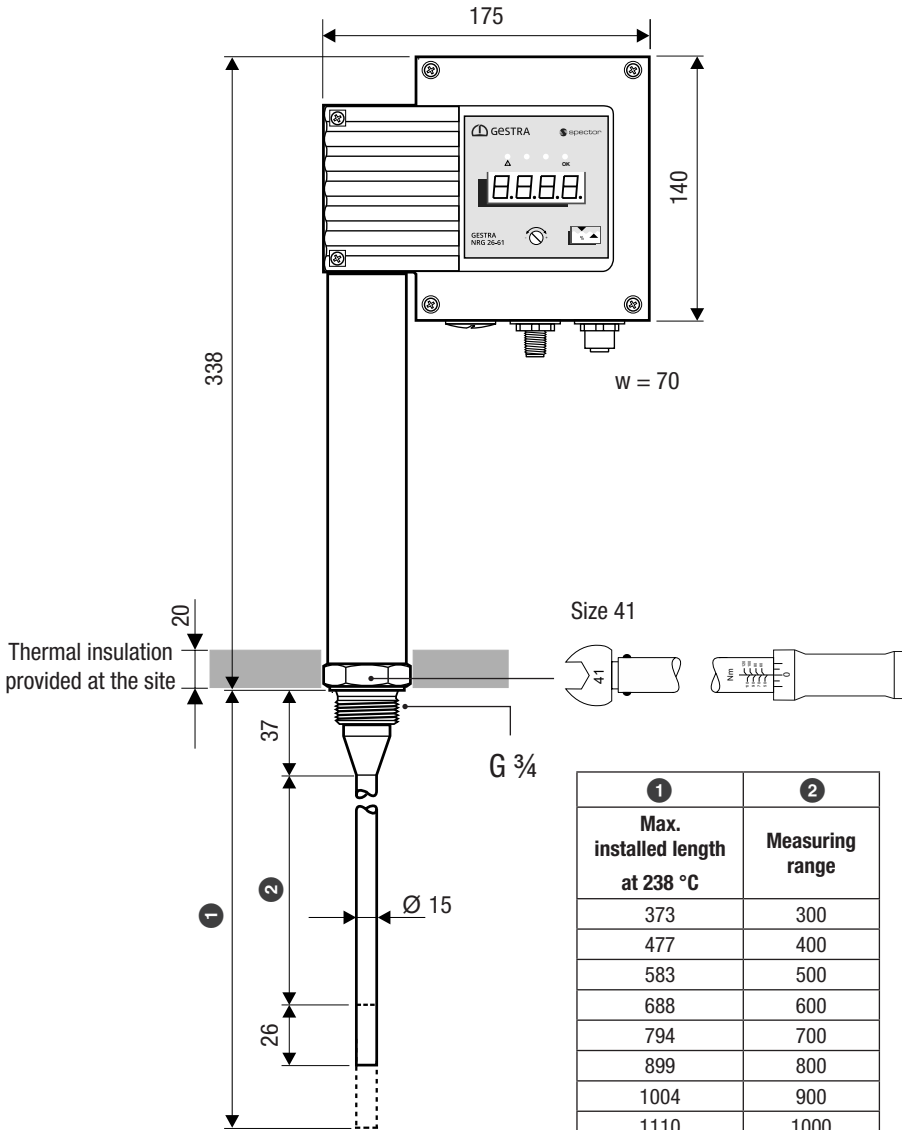

Fig. 7

Dimensions of the NRG 26-61



1	2
Max. installed length at 238 °C	Measuring range
373	300
477	400
583	500
688	600
794	700
899	800
1004	900
1110	1000
1214	1100
1319	1200
1423	1300
1528	1400
1636	1500
2156	2000

Fig. 8

All lengths and diameters in mm

Preparing for installation



If the equipment is to be installed outdoors, outside the protection of a building, environmental influences may adversely affect function.

- Pay attention to the admissible ambient conditions in the technical data, see page 18.
 - Do not operate the equipment if the temperature is below freezing.
 - ◆ At temperatures below freezing, use a suitable heat source (e.g. control cabinet heater, etc.).
 - Connect all plant parts to a central earthing point to prevent equalisation currents.
 - Use a cover to protect the equipment from direct sunlight, condensation and heavy rain.
 - Use UV-resistant cable ducts for routing the connecting cable.
 - Take further measures to protect the equipment from harmful environmental influences such as lightning, insects and animals, and salty air.
-

You will need the following tools:

- Torque wrench (with size 41 open-ended spanner attachment), see page 22:

Installation

DANGER



Danger to life from scalding caused by escaping hot steam.

Hot steam or water can escape suddenly if level electrodes are unscrewed under pressure.

- Reduce the boiler pressure to 0 bar and check the boiler pressure before you unscrew the level electrode.
- Only remove the level electrode at a boiler pressure of 0 bar.

WARNING



The hot level electrode can cause severe burns.



The level electrode becomes very hot during operation.

- Always let the level electrode cool down before performing installation and maintenance work.
- Only remove level electrodes that have cooled down.

ATTENTION



Incorrect installation can lead to malfunctions in the plant or the level electrode.

- Inspect the sealing surfaces of the tank standpipe or flange cover to ensure they are perfectly machined, see Fig. 9.
- Take care not to bend the level electrode during installation!
- Do not expose the electrode rod to hard knocks.
- The angle of inclination of the level electrode may be 45° only if it is being used in a two-hole flange, with the length of the electrode rod limited to 688 mm maximum, see Fig. 16.
- Do **not** install the body  or upper part of the sheath  of the level electrode in the boiler thermal insulation!
- Do not install in the screwed socket.
- Pay attention to the minimum clearances when installing the level electrode, see installation examples Fig. 12 to Fig. 16.
- To prevent current leaks, maintain a minimum distance of 14 mm between the electrode and earth (flange or tank wall).
- Check the boiler standpipe and flange during the preliminary boiler inspection.

Installation

1. Inspect the sealing surfaces of the tank stand-pipe or flange cover.

Sealing surfaces must be perfectly machined, as shown in Fig. 9.

Sealing surface dimensions for NRG 26-61

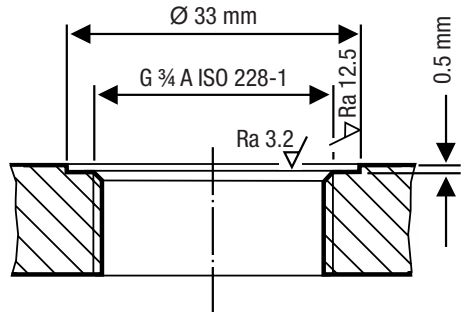

Fig. 9

2. Push the supplied sealing ring **H** onto the seal seat **G** of the electrode, or lay it on the sealing surface of the flange.

! DANGER



Danger to life from escaping hot steam if incorrect or defective seals are used.

- Only use the supplied sealing ring for sealing the electrode thread **I**.
- ◆ **Sealing ring D 27 x 32**
DIN 7603-2.4068, bright annealed

Prohibited seal materials:

- Hemp, PTFE tape
- Conductive paste or grease

Example

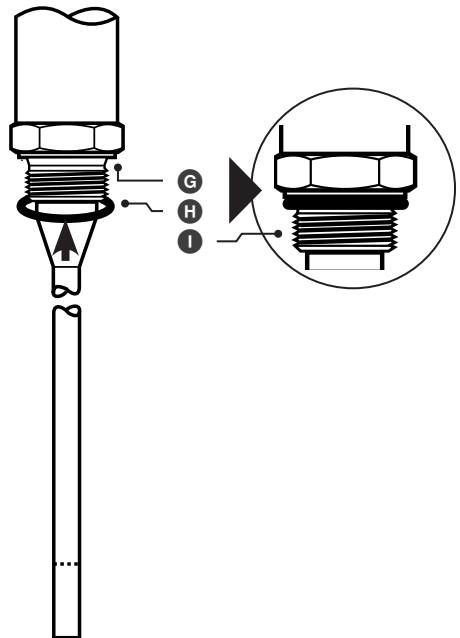

Fig. 10

Installation

3. If necessary, apply a small quantity of silicone grease (e.g. Molykote® P40) to the electrode thread **!**.
4. Screw the level electrode into the tank standpipe or flange cover, and tighten securely using a torque wrench (with size 41 open-ended spanner attachment).
Tighten to the torques stated below.

Tightening torque when cold:

- NRG 26-61 = 160 Nm

Installation example with dimensions, see Fig. 12, page 29

Installing two level electrodes in a flange by detaching a terminal box

When installing or removing the level electrode (e.g. when installing for the first time, during annual cleaning/maintenance or when taking out of service), you may need to completely detach the terminal box from the electrode because of space issues.



A self-locking nut connects the terminal box to the electrode. Therefore, before establishing the electrical connection, you can rotate the terminal box max. $\pm 180^\circ$ (a half turn) in the desired direction. This is often sufficient for alignment.

If, and only if, this option is not sufficient, completely detach the terminal box from the electrode and fit it again later on (see steps below).

ATTENTION



Incorrect installation can lead to malfunctions in the plant or the level electrode.

The steps below must be carried out exclusively by the manufacturer's service personnel or a specialist expressly authorised by the manufacturer to perform this work.



Avoid open circuits, damaging terminals and subsequent short circuits

- When screwing the level electrode into or out of the standpipe, take care not to twist or trap the connecting cables from the electrode to the terminal box!
- Therefore, detach all connecting cables from the electrode to the terminal box before unscrewing the level electrode from the standpipe.

Installation

Installing two level electrodes in a flange by detaching a terminal box

1. Fit the **first** electrode as described above.
2. Slacken and remove the rear body panel of the **second electrode** opposite the operating unit.

Interior view of terminal box:

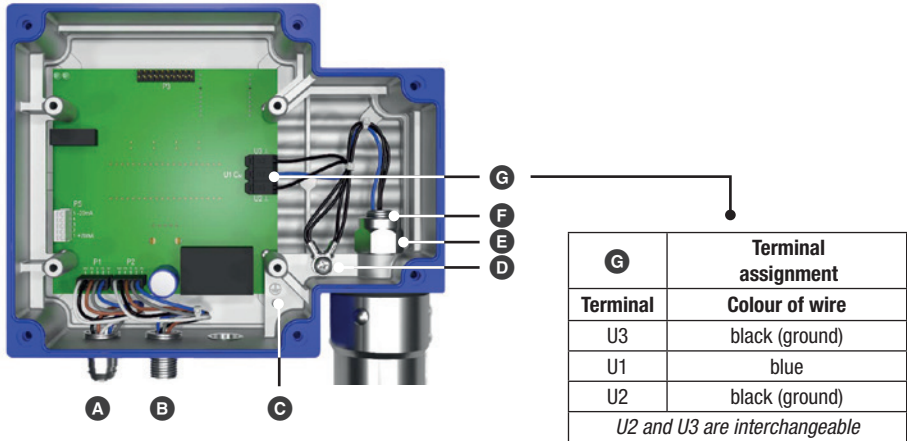

Fig. 11

Key:

- Ⓐ M12 socket
- Ⓑ M12 connector
- Ⓒ Ring cable lug no. 2
- Ⓓ Ring cable lug no. 1
- Ⓔ Self-locking nut (size 19)
- Ⓕ Cable gland for the connecting cable to the electrode
- Ⓖ Terminals
U1 (middle) / U2 (bottom) / U3 (top)

3. Detach the electrode connecting cables from the PCB:
 - Detach the ring cable lug Ⓓ from the terminal box
 - Detach the connecting cables from the terminals Ⓖ
4. Slacken the nut Ⓔ in the terminal box of the **second electrode** using a size 19 open-ended spanner.
5. You can now remove the terminal box or screw it onto the electrode.
When fully removing the terminal box, feed all detached connecting cables through the slackened nut and the hole in the terminal box.
6. Install the **second electrode** in the flange.

Installation

Installing two level electrodes in a flange by detaching a terminal box

7. Next, route all connecting cables through the hole in the terminal box and the nut once again.
8. Place the terminal box back on the electrode with the required orientation.



Ensure the terminal box is correctly orientated/aligned – position it correctly in advance.

9. Tighten the nut in the terminal box to a torque of 25 Nm.
10. Reconnect the electrode wiring to the PCB, see table in **Fig. 11**.
If necessary, use cable ties to tie the connecting cables together in the terminal box.
11. Screw the ring cable lug **D** (earth connection) back onto the terminal box.
12. Finally, check the wiring one more time.
13. Close the rear panel of the second electrode terminal box and screw back on.

Installation example with dimensions, see Fig. 14, page 31

Installation examples with dimensions

Protective tube (provided at the site) for internal installation.

Illustration not to scale.

Key, see page 34

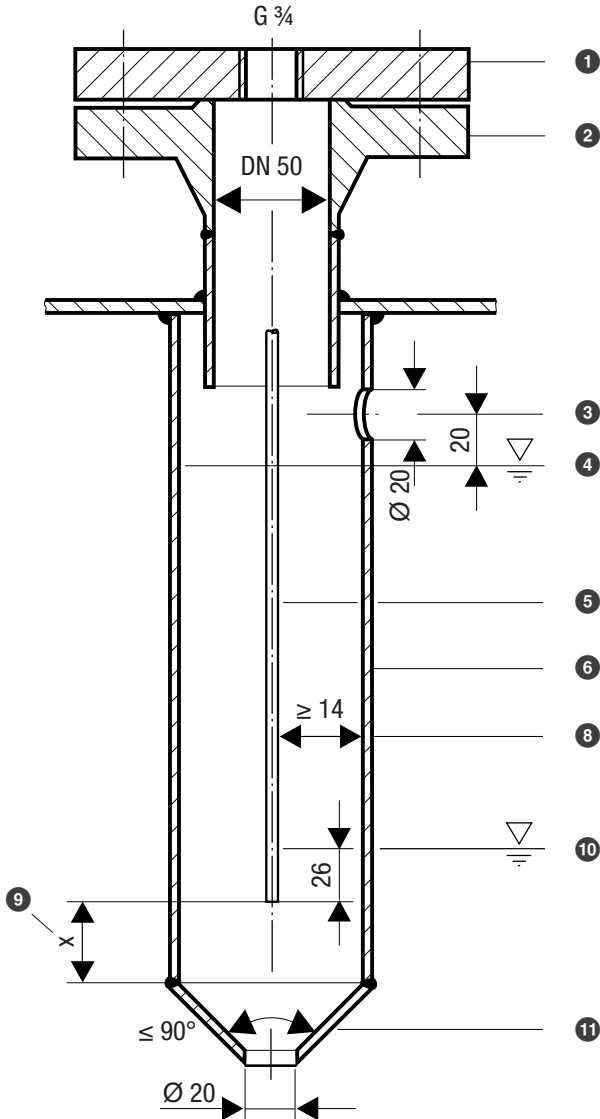

Fig. 12

All lengths and diameters in mm

Installation examples with dimensions

Protective tube (provided at the site) for internal installation.

Illustration not to scale.

Key, see page 34

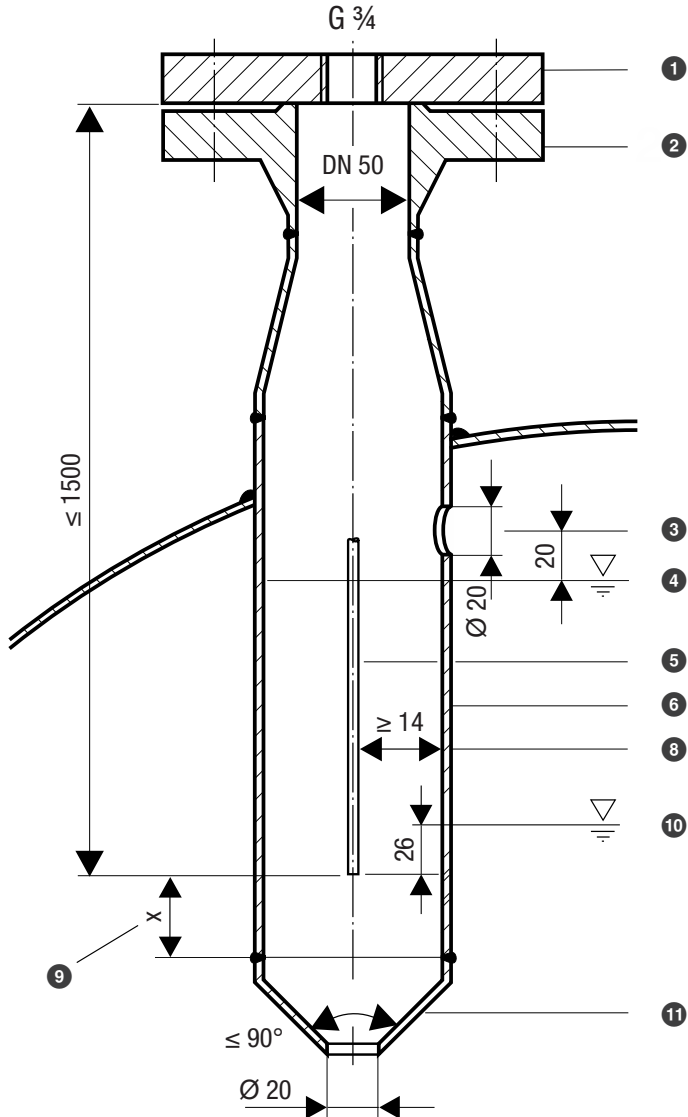

Fig. 13

All lengths and diameters in mm

Installation examples with dimensions

Level pot (\geq DN 80) for mounting externally.

Illustration not to scale.

Key, see page 34

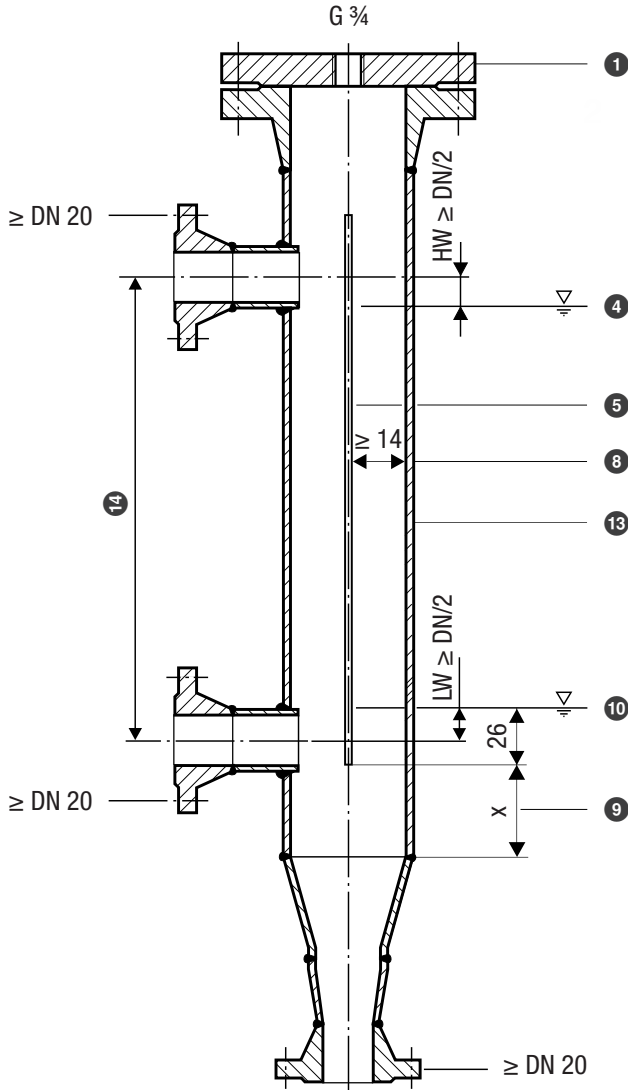

Fig. 15

All lengths and diameters in mm

Installation examples with dimensions

Oblique installation, e.g. in steam boilers.

The angle of inclination of the level electrode must not exceed 45° , and the length of the electrode rod is limited to 688 mm maximum.

Illustration not to scale.

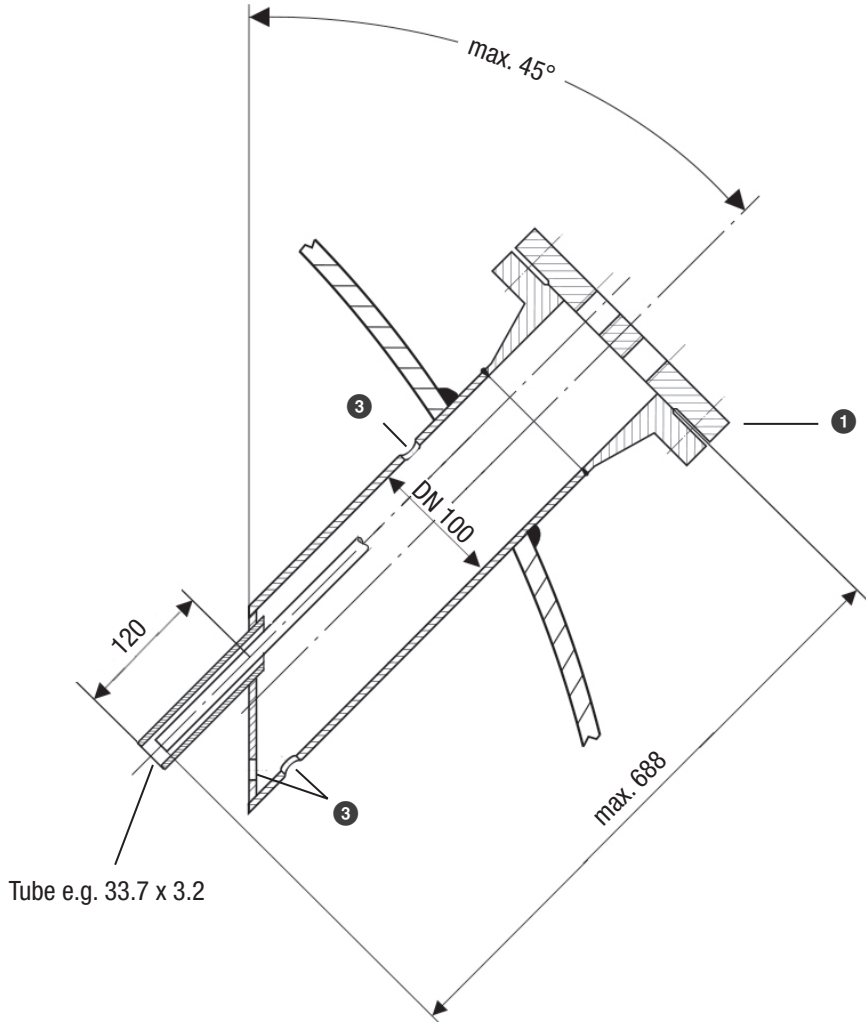

Fig. 16

All lengths and diameters in mm

Installation examples with dimensions

Key Fig. 12 to Fig. 16

- ① Fig. 11, 12: Flange (PN 40, DN 50) EN 1092-1 (single electrode)
Fig. 14: Flange (PN 40, \geq DN 80) EN 1092-1 (single electrode)
Fig. 13, 15: Flange (PN 40, DN 100) EN 1092-1 (two electrodes installed in one flange)
- ② Standpipe for connecting flange (perform preliminary inspection of standpipe during the boiler inspection)
- ③ Pressure relief hole \varnothing 20 mm
- ④ Highest possible HW mark
- ⑤ Electrode rod
- ⑥ Protective tube DN 80 (\geq DN 100 in France as per AFAQ)
- ⑦ Protective tube DN 100
- ⑧ Distance between electrode rod and protective tube \geq 14 mm
- ⑨ Minimum dimension (x) = 10 mm below the electrode length (electrode length, see page 17)
- ⑩ Lowest possible LW mark (end of measuring range)
- ⑪ Reducer EN 10253-2, K-88.9 x 3.2 - 42.4 x 2.6 W
- ⑫ Reducer EN 10253-2, K-114.3 x 3.6 - 48.3 x 2.9 W
- ⑬ Level pot \geq DN 80
- ⑭ Centre distance of standpipe
- ⑮ Additional electrode

Aligning the terminal box

If necessary, you can orientate the display in the desired direction by rotating the terminal box.

ATTENTION



Rotating the terminal box $\geq 180^\circ$ will damage the level electrode's internal wiring.

- Never rotate the terminal box more than 180 degrees in either direction.



If the terminal box needs to be rotated by $>180^\circ$ or fully removed, proceed as described on pages 26 to 28.

Functional elements

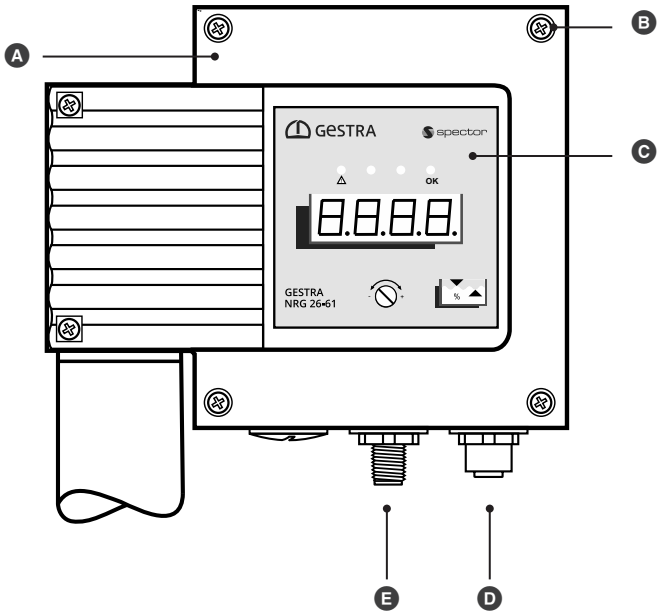

Fig. 17

- A** Terminal box
- B** Cover screws M4 x 16 mm
- C** Operating panel with 4-digit LED display/alarm and status LEDs and rotary knob, see page 49
- D** M12 CAN bus socket, 5-pole, A-coded
- E** M12 CAN bus connector, 5-pole, A-coded

Connecting the CAN bus system

Bus line, cable length and cross-section

- Use a shielded, multi-core, twisted-pair control cable, e.g. UNITRONIC® BUS CAN 2 x 2 x .. mm² or RE-2CYV-f1 2 x 2 x .. mm² as the bus line.
- Pre-wired control cables (with connector and coupling) are available as accessories in various lengths.
- The baud rate is determined by the line length (transfer rate) between the bus terminal devices, and the conductor size is determined by the overall current input of the measuring sensors.
- 0.2 A at 24 V is required per sensor. With five sensors, there is therefore a voltage drop of approx. 8 V per 100 m when using cables of 0.5 mm². In this case, the system is operating at its limits.
- With five or more sensors and a cable length of ≥ 100 m, the conductor size needs to be doubled to 1.0 mm².
- At larger distances of > 100 m, the 24 V DC supply can also be provided on site.

Example

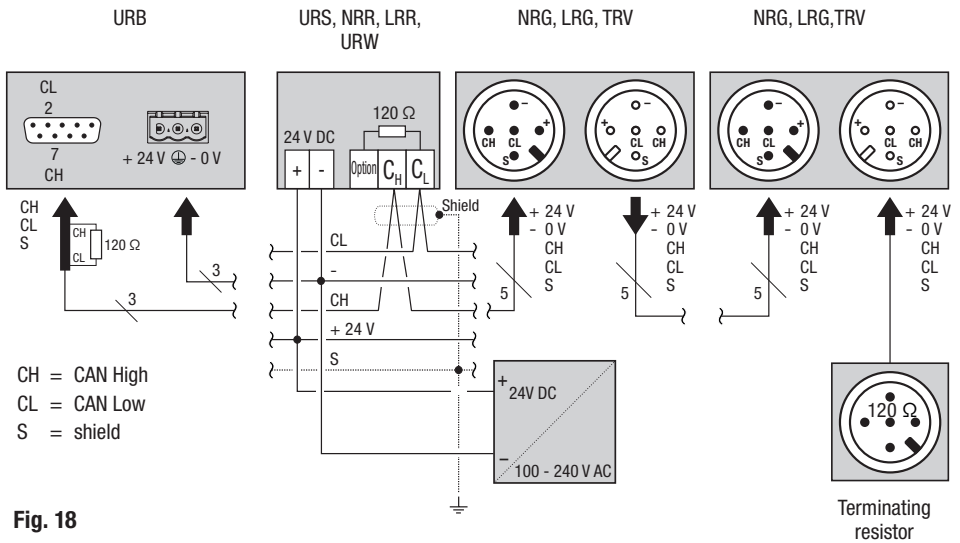

Fig. 18

Connecting the CAN bus system

Important notes on connecting the CAN bus system

- A dedicated 24 V DC SELV power supply unit that is isolated from connected loads must be used to supply the SPECTORconnect system.
- Make sure wiring is in line, not in a star!
- Use a central earth to prevent differences in potential between plant parts.
 - ◆ Connect the bus line shields to one another all the way along, and connect them to the central earthing point (CEP).
- If two or more system components are connected in a CAN bus network, a 120 Ω terminating resistor must be connected to the **first** and **last** devices between terminals C_L/C_H.
- Use the CAN bus connector with terminating resistor if you are using the level electrode as the first or last device.
- Only **one** URS 60 and **one** URS 61 safety control unit may be used in the CAN bus network.
- The CAN bus network must not be interrupted during operation!
If it is, an alarm is triggered.

Pin assignment of the CAN bus connector and coupling for non pre-wired control cables

If non pre-wired control cables are used, you must wire the CAN bus connectors and couplings as shown in the wiring diagram **Fig. 19**.

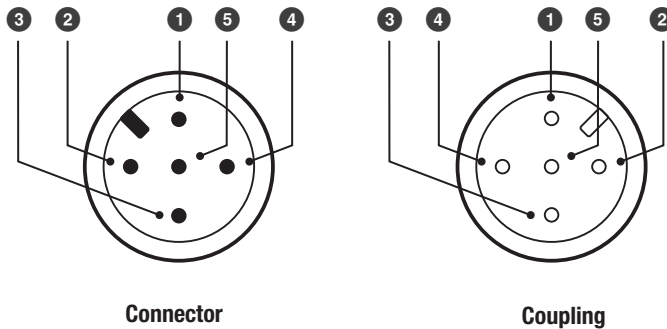

Fig. 19

- | | | |
|---|--------|--------------------|
| 1 | S | Shield |
| 2 | + 24 V | Power supply |
| 3 | 0 V | Power supply |
| 4 | CH | CAN High data line |
| 5 | CL | CAN Low data line |

Bringing into service

Before bringing into service, check that all equipment is correctly connected:

- Is the polarity of the CAN bus control line correct throughout?
- Is a 120 Ω terminating resistor connected to the terminal devices of the CAN bus line?

Next, switch on the supply voltage.

Changing the factory settings if necessary

You will need the following tools

- Size 2.5 slotted screwdriver

Notes on bringing into service for the first time



When the equipment is brought into service for the first time, the “**AL.Lo**” and “**AL.Hi**” alarm limits are set to Max/Min values, which is why the warning messages “**LO.LE**” and “**HI.LE**” are shown alternately on the display.

First, set the “**AL.Lo**” and “**AL.Hi**” alarm limits to suitable values for your specific plant, see page 43.



Calibration of the measuring range and setting alarm limits are mutually independent processes.

Changing parameters with password protection enabled



When password protection is enabled, you must enter the password before changing parameters, see page 39. Password protection applies only to the menu items with parameters that the user can actually change.



Menu items that can only display values (i.e. not parameters) are not covered by password protection. You can retrieve information about this at any time.

Password protection after restarting the equipment



Parameters are also password-protected when the equipment has been restarted, if password protection was previously enabled, see page 47.

Default ex-works password

The default password is “**1902**” and cannot be changed. Password protection is available from software version S-16 onwards.

Bringing into service

Selecting and setting a parameter:



Using the screwdriver, turn the rotary knob clockwise or anti-clockwise until the desired parameter appears on the display. The set value is displayed after approx. 3 seconds.

The display alternates between the set parameter and its actual value, e.g. bd.rt → “value” → bd.rt.

When you turn the rotary knob clockwise, the following parameters are shown in turn:

“Actual value” → Id.Lo → Id.Hi → GrP → bd.rt → °C.in → AL.Lo → AL.Hi → CAL.L → CAL.P → CAL.H → Filt → diSP → ConP → InFo → PW → “Actual value”

Key to parameters, see page 40.



If you do not enter anything for 30 seconds, the display automatically returns to the actual value.



Once you have selected a parameter, press and hold the rotary knob until:

- “PASS” appears on the display and password entry is therefore extended; move on to step 3.

or (password protection disabled)

- the current parameter value flashes on the display; move on to step 8.

With password entry:

3.

Release the rotary knob.



Next, press and hold the rotary knob until “0000” appears on the display and the right-hand digit flashes.



Enter the password “1902”. You can skip to the next flashing digit by briefly pressing the rotary knob.

- / + reduce/increase the value.



After the final digit, press and hold the rotary knob until “done” is displayed.

The display then alternates between the selected parameter and its current value.



Press and hold the rotary knob until the current parameter value flashes on the display. Move on to step 8.

Bringing into service

Without password entry:

8.  Set the desired value.
- / + reduce/increase the value

Each parameter has an individual, admissible value range.

By pressing the knob briefly, you can skip to the next digit. This is a more convenient way of making large changes to values.



If you do not set a parameter within 10 seconds, the process is aborted (“quit”) and the old parameter value is retained.

9.  Save your settings by pressing the rotary knob for approx. 1 second.
The message “done” is shown and the parameter appears on the display once more.

Pay attention to the time limit for password entry



Disabled password protection is re-enabled after 30 minutes without any activity (rotary knob), and the password must then be entered again.

Key to parameters:

- 099.9 = actual value display, the current level reading based on the 0-100% calibration
- Id.Lo = limiter ID; for the LW limiter function *
- Id.Hi = limiter ID; for the HW limiter function *
* Effect on the URS 6x safety control unit
- GrP = controller group (effect on URB 60/SPECTOR*control*)
- bd.rt = baud rate
- °C.in = display ambient temperature of terminal box
- AL.Lo = set the LW alarm limit for the limiter function
- AL.Hi = set the HW alarm limit for the limiter function
- CAL.L = calibrate start of measuring range to 0%
- CAL.P = calibrate measuring range to an intermediate value above 25% (alternative to CAL.H)
- CAL.H = calibrate end of measuring range to 100%
- Filt = filter constant
- diSP = initiate a display test
- ConP = activate compatibility mode; do not change this setting when operating with the SPECTORconnect (ConP = oFF)
- InFo = view software version and equipment type
- PW = enable/disable password protection

Bringing into service

Notes on changing communication parameters “bd.rt, Id.Lo; Id.Hi or GrP”



All CAN bus equipment from GESTRA AG has default ex-works parameter settings, which enable a standard system to be brought into operation without making any changes.

Please follow the steps below if you need to make changes to communication parameters:

- Set the same baud rate for all bus nodes.
- To apply changed communication parameters, perform the steps below on the URB 60 visual display and operating unit or the SPECTOR*control*.
 - ◆ **Reimport the list of equipment**



To do this, please read the instructions in the Installation & Operating Manual of the URB 60 visual display and operating unit or SPECTOR*control*.

Changing the “Id.Lo / Id.Hi” limiter ID



To set the limiter ID, please also read the instructions in the Installation & Operating Manual of the URS 60/URS 61 safety control unit.

The limiter ID defines the channel on the relevant safety control unit

ID = 1	>	URS 60, channel 1
ID = 2	>	URS 60, channel 2
ID = 3	>	URS 60, channel 3
ID = 4	>	URS 60, channel 4

ID = 5	>	URS 61, channel 1
ID = 6	>	URS 61, channel 2
ID = 7	>	URS 61, channel 3
ID = 8	>	URS 61, channel 4

Pay attention to the setting instructions on page 39 and proceed as follows:

1. Select the parameter “**Id.Lo or Id.Hi**”.
 - Id.Lo = limiter ID for low-level electrode 2
 - Id.Hi = limiter ID for low-level electrode 1
2. Press and hold the rotary knob until the current limiter ID flashes on the display.
3. Set the desired ID (off/0001 to 0008).
 - off = the NRG 26-61 level electrode has no effect on the URS 60/URS 61 safety control unit.
4. Save your setting by pressing the rotary knob for approx. 1 second.

Bringing into service

Changing the controller group “GrP”



For setting the controller group, please also pay attention to the information in the Installation & Operating Manual of the NRR 2-60 or NRR 2-61 level controller.

Pay attention to the setting instructions on page 39 and proceed as follows:

1. Select the parameter “**GrP**”.
2. Press and hold the rotary knob until the current controller group ID flashes on the display.
3. Set the desired controller group (1 to 4). The controller groups correspond to the following CAN bus node IDs:
Controller group 1 = node ID 40
Controller group 2 = node ID 45
Controller group 3 = node ID 60
Controller group 4 = node ID 65
4. Save your setting by pressing the rotary knob for approx. 1 second.

Changing the baud rate “bd.rt”



Set the same baud rate for all bus nodes.

Pay attention to the setting instructions on page 39 and proceed as follows:

1. Select the parameter “**bd.rt**”.
2. Press and hold the rotary knob until the current baud rate flashes on the display.
3. Set the desired baud rate (50 kbit/s or 250 kbit/s).
4. Save your setting by pressing the rotary knob for approx. 1 second.

Bringing into service

Notes for setting the “AL.Lo” and “AL.Hi” alarm limits



This setting only applies to the limit for safety shutdown by the URS 60/URS 61 safety control unit.

It does not affect the limit signal contacts of the NRR 2-60 or NRR 2-61 level controller.



Please also see the information in the relevant Installation & Operating Manual.

Always set the alarm limits with the plant at its operating point.

If the alarm limits were previously set in a cold state, you must enter the settings again at the operating point.

Setting the “AL.Lo” (low-level alarm = LW) limit

Pay attention to the setting instructions on page 39 and proceed as follows:

1. Select the parameter “AL.Lo”.
2. Bring the boiler water to the desired low water level.
3. Save your setting by pressing the rotary knob for approx. 1 second.

Checking the set “AL.Lo” limit or switchpoint



You need to check the switchpoint by letting the fluid fall below the set “AL.Lo” limit. In this case, the equipment must behave as if there were an alarm.

Always check the switchpoint when bringing into service, after changing a limit, and each time the NRG 26-61 level electrode is replaced, and do this at the plant’s operating point.

Setting the “AL.Hi” (high-level alarm = HW) limit

Pay attention to the setting instructions on page 39 and proceed as follows:

1. Select the parameter “AL.Hi”.
2. Bring the boiler water to the desired high water level.
3. Save your setting by pressing the rotary knob for approx. 1 second.

Checking the set “AL.Hi” limit or switchpoint



You need to check the switchpoint by letting the fluid rise above the set “AL.Hi” limit. In this case, the equipment must behave as if there were an alarm.

Always check the switchpoint when bringing into service, after changing a limit, and each time the NRG 26-61 level electrode is replaced, and do this at the plant’s operating point.

Bringing into service

Notes on calibration



Always perform calibration with the boiler fluid at the operating point

If you set the measuring range while the fluid is cold, the settings will change on exposure to heat and the set measuring range then need to be corrected at the operating point.

Calibrate the lower limit of the active measuring range “CAL.L” (0% calibration value)



Bring the level to 0% and perform calibration.

Pay attention to the setting instructions on page 39 and proceed as follows:

1. Reduce the level of water in the boiler to the 0% limit of the desired measuring range.
2. Select the parameter “**CAL.L**”. After approx. 3 seconds, the old value is shown in hexadecimals.
3. Press and hold the rotary knob until the new value is displayed.
4. Save your setting by pressing the rotary knob for approx. 1 second.
5. Continue with calibration “**CAL.P**” or “**CAL.H**”.

Perform independent rapid calibration at a water level of > 25% of the active measuring range “CAL.P”



This parameter enables partial filling of the boiler, as an alternative to complete filling. The value set for partial filling is extrapolated to 100% of the boiler level.

Pay attention to the setting instructions on page 39 and proceed as follows:

1. Increase the level of water in the boiler to > 25% of the desired measuring range.
2. Select the parameter “**CAL.P**”. After approx. 3 seconds, the old value is shown in hexadecimals.
3. Press and hold the rotary knob until the value (e.g. 0025) appears. The last digit flashes.
4. Set the desired reading to > 25% to match the set level.
5. Save your setting by pressing the rotary knob for approx. 1 second.

Bringing into service

Calibrate the upper limit of the active measuring range "CAL.H" (100% calibration value)



Calibration with "CAL.H" ensures the best possible accuracy for setting the measuring range.

Pay attention to the setting instructions on page 39 and proceed as follows:

1. Increase the level of water in the boiler to the 100% limit of the desired measuring range.
2. Select the parameter "**CAL.H**". After approx. 3 seconds, the old value is shown in hexadecimals.
3. Press and hold the rotary knob until the new value is displayed.
4. Save your setting by pressing the rotary knob for approx. 1 second.

Setting the filter constant "Filt"



Here, you can set a damping time constant to smooth the output signal for the level controller and the display. The filter constant only affects the display and control, and is set at a fixed value for the limiter.

Pay attention to the setting instructions on page 39 and proceed as follows:

1. Select the parameter "**Filt**".
2. Press and hold the rotary knob until the current time constant flashes on the display.
3. Set the desired time constant (1 to 30 seconds).
4. Save your setting by pressing the rotary knob for approx. 1 second.

Manually initiating a display test

Pay attention to the setting instructions on page 39 and proceed as follows:

1. Select the parameter "**diSP**".
2. Press and hold the rotary knob until the display test starts and shows "....".
3. The following numbers and decimal points run across the display from right to left: "**...., 1, 2, 3, 4, 5, 6, 7, 8, 9,**"
4. Check that all numbers and decimal points are displayed correctly.
The display test runs automatically until it has finished, and cannot be interrupted.
5. The display test ends with "**donE**".

Replacing faulty equipment



Faulty equipment jeopardises plant safety.

- If numbers or decimal points are displayed incorrectly or not at all, you must replace the level electrode with an identical one from GESTRA AG.

Bringing into service

Activating URB 2 compatibility “ConP”



For operation with SPECTORconnect, do not change this setting (ConP = oFF).

1. Select the parameter “**ConP**”.
2. Press and hold the rotary knob until the current status flashes on the display.
3. Set the required status (off/on).
ConP = on: This enables the higher-resolution NRG 26-61 readings to be displayed on the URB 2 operating terminal (by conversion from 16 bit to 10 bit).
ConP = oFF: 16-bit resolution of the NRG 26-61 readings.
4. Save your setting by pressing the rotary knob for approx. 1 second.

Viewing the software version and equipment type “InFo”

Pay attention to the setting instructions on page 39 and proceed as follows:

1. Select the parameter “**InFo**”.
2. The display shows the software version “**S-xx**” alternating with “**InFo**”.

Then view the equipment type (see 3. and 4.) or quit the menu (see 5.):

3. Press and hold the rotary knob until the software version is continuously displayed.
4. Turn the rotary knob clockwise or anti-clockwise to view the equipment type.
5. You can quit the menu by pressing and holding (message “**donE**”) or by waiting (message “**quit**”).

Bringing into service

Enabling/disabling password protection

The default ex-works password cannot be changed

- The default password is “**1902**”.
- Password protection is available from software version S-16 onwards.

Pay attention to the setting instructions on page 39 and proceed as follows:

1. Select the parameter “**PW**”.
“**PW**” alternates with the current status, e.g. “**oFF** or **on**”, on the display.
2. Press and hold the rotary knob until “**PASS**” is displayed.
3. Release the rotary knob.
4. Next, press the rotary knob until “**0000**” appears and the right-hand digit flashes.
5. Enter the password “**1902**”. You can skip to the next flashing digit by briefly pressing the rotary knob.
6. After the final digit, press and hold the rotary knob until “**donE**” is displayed.

The following may appear on the display:

- **donE** The correct password was entered
 - **FAiL** The wrong password was entered
 - **quit** Timeout. Password entry has been aborted.
7. Release the rotary knob.
“**PW**” alternates with the current status, e.g. “**oFF** or **on**”, on the display.
 8. Press the rotary knob again until “**oFF** or **on**” flashes on the display.
 9. Turn the rotary knob and set the desired status.
 - **on** = password protection is enabled
 - **oFF** = password protection is disabled
 10. Press and hold the rotary knob until “**donE**” is displayed.
 11. Release the rotary knob.
“**PW**” alternates with the set status, e.g. “**oFF** or **on**”, on the display.
 12. You can quit the menu by waiting (message “**quit**”) or by turning the rotary knob to the actual value.

Bringing into service

Checking the LW and HW limiter switchpoints by raising or reducing the level



Incorrectly installed or bent level electrodes result in a loss of function that can jeopardise plant safety.

Therefore, proceed as follows when bringing into service and when replacing the NRG 26-61 level electrode:

- Check the LW and HW limiter switchpoints by allowing the level to fall below the lower limit and rise above the upper limit at the plant's operating point.
- Never start up any plant that has not passed the above switchpoint check.
- The NRG 26-61 level electrode may only be repaired by the manufacturer, GESTRA AG.
- Only replace faulty equipment with identical equipment from GESTRA AG.

Checking the limiter switchpoints by initiating a test function

Check the AL.Lo and AL.Hi alarm limits of the limiter function by initiating the test function with the rotary knob, see page 52, Test table.

In this case, the equipment must behave as if there were an alarm.

Lockout function



If the installation requires a lockout function, this must be implemented in the downstream (safety) circuit. This circuit must conform to the requirements of EN 50156.

Starting, operation and testing

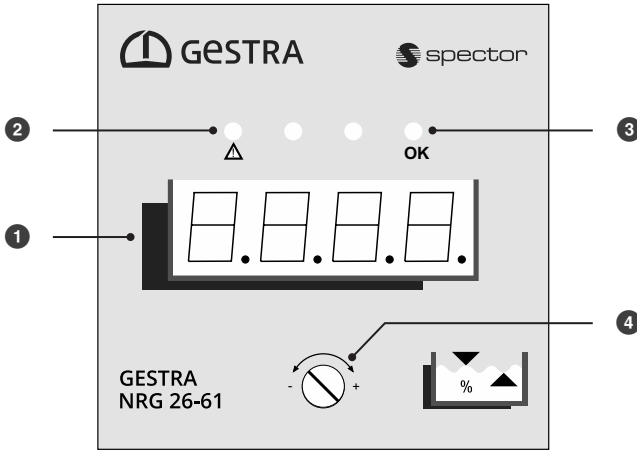

Fig. 20

The operating panel:

- 1 Actual value display/error code/limit value, green, 4 digits
- 2 LED 1, alarm/fault, red
- 3 LED 2, function OK, green
- 4 Rotary knob/pushbutton for operation and settings

Notes on the priority of the various indications



Fault indications and alarms are displayed based on their priority. Indications with higher priority are shown continuously before those with low priority. If several indications need attention, the display does not alternate between them.

Priority 1 = fault indications as per error code table, see page 54 ff.

Priority 2 = low-level (LW) alarm

Priority 3 = high-level (HW) alarm

Priority of error code display

Higher priority error codes overwrite lower ones on the display!

Starting, operation and testing

Relationship between display and LEDs and the operating state of the level electrode:

Starting		
Switch on supply voltage	<p>All LEDs light up - Test</p> <p>Indication: S-xx = software version t-07 = equipment type NRG 26-61</p>	<p>The system is started and tested.</p> <p>The LEDs and display are tested.</p>

Bringing into service for the first time		
Switch on supply voltage	<p>Indication: LO.LE + HI.LE alternating</p> <p>LED 1: Alarm LED lights up red</p> <p>LED 2: Operating LED is off</p>	<p>Low and high-level alarm (LW and HW) based on factory-set alarm limits “AL.Lo” and “AL.Hi”.</p>
		<p>First, set the alarm limits to suitable values for your specific plant, see page 43.</p>

Normal operation		
The level electrode is immersed within the set measuring range	<p>Indication: e.g. 047.3</p> <p>LED 2: Operating LED lights up green</p>	<p>The current level is shown as a % of the calibrated measuring range.</p>

See the following pages for more information and tables.

Starting, operation and testing

Behaviour in the event of a low-level alarm (LW)		
The level electrode is only immersed to below the low-level mark (LW) The level is below the AL.Lo alarm limit	Indication: LO.LE and e.g. 009.5 alternating	The alarm message (Low Level) and the current reading are shown alternately on the display
	LED 1: Alarm LED lights up red	The MIN alarm is active
	LED 2: Operating LED is OFF	Alarm is triggered
Behaviour in the event of a high-level alarm (HW)		
The level electrode is immersed to above the high-level mark (HW) The level is above the AL.Hi alarm limit	Indication: HI.LE and e.g. 092.5 alternating	The alarm notification (High Level) and the current reading are shown alternately on the display
	LED 1: Alarm LED lights up red	The MAX alarm is active
	LED 2: Operating LED is OFF	Alarm is triggered
<ul style="list-style-type: none"> ■ The alarm state is transferred to the URS 60/URS 61 safety control unit via CAN data telegram. ■ There, once the time delay has elapsed, the alarm notification triggers a safety shutdown. ■ The affected signal output is activated. ■ The URS 60/URS 61 safety control unit does not automatically lock the safety contacts. 		

Behaviour in the event of a malfunction (error code display)		
On the occurrence of a fault	Indication: e.g. E.005	An error code is continuously displayed, error codes see page 54
	LED 1: Alarm LED lights up red	A fault indication is active
	LED 2: Operating LED is OFF	A fault is present
<ul style="list-style-type: none"> ■ The fault or error state is transferred to the URS 60/URS 61 safety control unit via CAN data telegram. ■ The fault triggers an immediate safety shutdown there. ■ The affected signal output is activated. ■ The URS 60/URS 61 safety control unit does not automatically lock the safety contacts. 		



Electrode alarms and fault indications cannot be acknowledged.

When the alarm or fault indication is cancelled the display also goes blank, and the URS 60/URS 61 safety control unit closes the safety contacts and deactivates the relevant signal outputs once more.

Starting, operation and testing



When password protection is enabled, you must enter the password before running the test function.

Testing		
Checking the safety function by simulating the alarm state		
<p>In operating mode: Press the rotary knob on the NRG 26-61 and hold until the end of the test: 1 x press and hold = low-level (LW) alarm 2 x press and hold = high-level (HW) alarm or press button 1, 2, 3 or 4 of the URS 60/URS 61 safety control unit and hold until the end of the test or initiate the limiter test for the NRG 26-61 level electrode on the URB 60.</p>	<p>Indication: e.g. LO.LE and 000.0 alternating</p>	The test simulates water falling below the LW mark or rising above the HW mark.
	<p>e.g. HI.LE and 100.0 alternating</p>	The alarm notification and simulated reading are shown alternately on the display
	<p>LED 1: Alarm LED lights up red</p>	MIN or MAX alarm
	<p>LED 2: Operating LED is OFF</p>	Alarm is triggered
	<ul style="list-style-type: none"> ■ The URS 60/URS 61 safety control unit or equipment behaves as if there were a real alarm. ■ Once the delay time has elapsed, the output contacts of the URS 60/URS 61 are opened and the corresponding signal outputs are activated. ■ The test has now finished 	



Faulty equipment jeopardises plant safety.

- If the level electrode does not behave as described above, it may be faulty.
- Perform failure analysis.
- The NRG 26-61 level electrode may only be repaired by the manufacturer, GESTRA AG.
- Only replace faulty equipment with identical equipment from GESTRA AG.

System malfunctions

Causes

System malfunctions occur if CAN bus components have been incorrectly installed or configured, if the equipment has overheated, if there is interference in the supply network or if electronic components are faulty.

Check the installation and configuration before beginning systematic troubleshooting!

Installation:

- Check that the installation location complies with the admissible ambient conditions in terms of temperature, vibration, interference sources, minimum distances, etc.

Wiring:

- Does the wiring conform to the wiring diagrams?
- Is the bus line polarity correct throughout?
- Is a 120 Ω terminating resistor connected to the terminal devices of the CAN bus line?

Configuration of the level electrode:

- Is the level electrode set to the correct limiter ID 1,2,3,4,5,6,7,8?
- Limiter IDs cannot be assigned more than once.
- Is the level electrode set to the correct controller group GrP = 1, 2, 3 or 4?

Baud rate:

- Is the cable length suitable for the set baud rate?
- Is the baud rate identical for all devices?

ATTENTION



Interrupting the CAN bus causes a plant shutdown and triggers an alarm.

- Bring the plant into a safe operating state before commencing work on the installation.
 - Switch off the voltage to the plant and secure so that it cannot be switched back on.
 - Check that the plant is not carrying live voltage before commencing work.
-

System malfunctions

Indication of system malfunctions using error codes

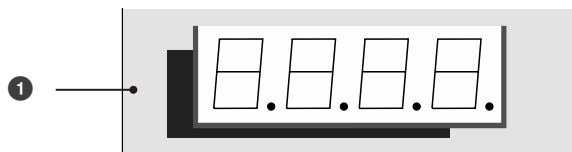

Fig. 21 ① Actual value display/error code/limit value, green, 4 digits

Error code display			
Error code	Internal designation	Possible errors	Remedy
E.001	MinCh1Err	Channel 1 reading below minimum, possible internal open circuit	Is the level electrode no longer immersed? Check the installation location. Broken electrode rod? If necessary, replace the level electrode
E.002	MinCh2Err	Channel 2 reading below minimum, possible internal open circuit	Is the level electrode no longer immersed? Check the installation location. Broken electrode rod? If necessary, replace the level electrode
E.003	MaxCh2Err	Channel 2 reading above maximum, possible internal open circuit	Damage to electrode rod PTFE (e.g. crack)? Replace the level electrode
E.004	Ch1Ch2DiffErr	Difference between channels 1 and 2 exceeds 10% fault tolerance, internal short circuit	Damage to electrode rod PTFE (e.g. crack)? Replace the level electrode
E.005	MaxCh1Err	Channel 1 reading above maximum, possible internal open circuit	Damage to electrode rod PTFE (e.g. crack)? Replace the level electrode
E.006	MinTSTCh1Err	Channel 1 reading internal capacitance (47pF)	Replace the level electrode
E.007	MaxTSTCh1Err	Channel 1 reading reference capacitance (1nF 47pF)	Replace the level electrode
E.008	MinTSTCh2Err	Channel 2 reading internal capacitance (47pF)	Replace the level electrode
E.009	MaxTSTCh2Err	Channel 2 reading reference capacitance (1nF 47pF)	Replace the level electrode
E.010	PWMTSTCh1Err	Channel 1 reading with disabled measurement signal	Replace the level electrode
E.011	PWMTSTCh2Err	Channel 2 reading with disabled measurement signal	Replace the level electrode

System malfunctions

Error code display			
Error code	Internal designation	Possible errors	Remedy
E.012	FreqErr	Measurement signal frequency	Replace the level electrode
E.014	ADSReadErr	16-bit AD converter is not responding	Replace the level electrode
E.015	UnCalibErr	Factory calibration invalid (not measuring range calibration)	Replace the level electrode
E.016	PlausErr	Measuring range plausibility error	Check measuring range calibration, repeat if necessary
E.019	V6Err	System voltage 6 V outside limits	Replace the level electrode
E.020	V5Err	System voltage 5 V outside limits	Replace the level electrode
E.021	V3Err	System voltage 3 V outside limits	Replace the level electrode
E.022	V1Err	System voltage 1 V outside limits	Replace the level electrode
E.023	V12Err	System voltage 12 V outside limits	Replace the level electrode
E.024	CANErr	Communication failure	Check the baud rate, wiring and terminating resistors
E.025	ESMG1Err	µC error	Replace the level electrode
E.026	BISTErr	µC periphery self-test error	Replace the level electrode
E.027	OvertempErr	PCB temperature, ambient temperature > 75 °C	Check the installation location. Lower the ambient temperature of the terminal box (cool if necessary)

All E.013, E.017 and E.018 error codes not listed here are available as reserves



Virtually all of the aforementioned error codes can be caused by EMC interference. This is less likely to be the case for permanent errors, but should be considered for sporadic error codes.

System malfunctions

Common application and usage errors

The 0% and 100% measuring range limits are obviously outside the sight glass level.

Possible causes if no error codes are shown	Remedy
The measuring range is incorrectly set.	<ul style="list-style-type: none"> ■ Check the measuring range calibration. ■ Repeat calibration if necessary.

The characteristic of the measurement signal in the measuring range is reproducible, but not linear.

Possible causes if no error codes are shown	Remedy
The level electrode was installed without a protective tube. The protective tube is required as a counter electrode.	<ul style="list-style-type: none"> ■ Install a protective tube.

The characteristic of the displayed reading appears implausible compared with the trend of the level in the sight glass.

Possible causes if no error codes are shown	Remedy
The pressure relief hole is clogged or flooded, or may even be missing completely.	<ul style="list-style-type: none"> ■ Check the protective tube ■ If necessary, add a pressure relief hole.
The stop valves of an externally mounted measuring cylinder (option) are closed.	<ul style="list-style-type: none"> ■ Inspect stop valves, open if necessary.

A correctly set electrode that has been in operation for a long period delivers increasingly imprecise readings.

Possible causes if no error codes are shown	Remedy
Increasing soiling due to build-up of deposits on the electrode rod.	<ul style="list-style-type: none"> ■ Remove the level electrode and clean the electrode rod with a damp cloth.

A control unit, e.g. NRR2-60, indicates a MIN or MAX alarm even though the level visible in the sight glass remains within the admissible measuring range limits.

Possible causes if no error codes are shown	Remedy
<ul style="list-style-type: none"> ■ The measuring range is incorrectly set. ■ The electrode or protective tube is soiled. 	<ul style="list-style-type: none"> ■ Calibrate the measuring range at the operating point. ■ Inspect the electrode and protective tube for soiling and clean if necessary.

System malfunctions

The display or control unit reacts to changes of level too slowly or too quickly.

Possible causes if no error codes are shown	Remedy
The damping coefficient "Filt" is not set to an optimum level.	Correct the damping coefficient "Filt".

The equipment fails to work. No display and the LEDs do not light up.

Possible causes if no error codes are shown	Remedy
Supply voltage failure.	<ul style="list-style-type: none"> ■ Switch on the supply voltage. ■ Check all electrical connections.

The equipment fails to work. The display is on and the LEDs light up.

Possible causes if no error codes are shown	Remedy
The earth connection to the tank is interrupted.	<ul style="list-style-type: none"> ■ Clean the sealing surfaces and ■ screw in the level electrode with a metal sealing ring, see page 25.

Flashing values from t-71 to t-75 appear on the display

Possible causes	Remedy
<p>The ambient temperature of the electrode terminal box is high, between 71 °C and 75 °C.</p> <p>If the temperature rises above 75 °C, the error code E.027 (Overtemp Err) appears and the plant shuts down.</p>	<ul style="list-style-type: none"> ■ Reduce the ambient temperature around the terminal box, e.g. by cooling.

System malfunctions

Checking installation and function

When you have remedied system malfunctions, perform a function test as follows.

- Check the limiter functions by allowing the fluid to fall below the set low-level limit (LW) and rise above the set high-level limit (HW). Then, the equipment must behave as if there were an alarm.
- Check the switchpoint when bringing into service and every time the NRG 26-61 level electrode is replaced.



System malfunctions of the NRG 26-61 level electrode also trigger a system malfunction on the URS 60/URS 61 safety control unit. The output contacts open without a delay and the relevant signal output is activated.

If you require assistance, please tell us the indicated error code.



In the event of malfunctions or faults that cannot be remedied with the aid of this Installation & Operating Manual, please contact our service centre or authorised agent in your country.

Taking out of service/Disassembly

DANGER



Danger to life from scalding caused by escaping hot steam.

Hot steam or water can escape suddenly if level electrodes are unscrewed under pressure.

- Reduce the boiler pressure to 0 bar and check the boiler pressure before unscrewing the level electrode.
- Only remove the level electrode at a boiler pressure of 0 bar.

WARNING



The hot level electrode can cause severe burns.

The level electrode is very hot during operation.

- Always let the level electrode cool down before performing installation and maintenance work.
- Only remove level electrodes that have cooled down.

Proceed as follows:

1. Reduce the boiler pressure to 0 bar.
2. Allow the level electrode to cool to room temperature.
3. Switch off the supply voltage.
4. Unplug the connections of the CAN bus control lines and plug them into one another.
5. Next, remove the level electrode.



An alarm is triggered when the CAN bus cable is interrupted.



If the terminal box needs to be rotated by **>180°** in relation to the electrode or needs to be fully removed, proceed as described on pages 26 to 28.

Cleaning the level electrode

Cleaning interval

We recommend cleaning the electrode once a year or more, depending on the operating conditions, e.g. during maintenance work.



Before cleaning the electrode rod, take the level electrode out of service and remove it, see page 59.

Cleaning

- Clean the PTFE protective sleeve by wiping it with a clean, damp cloth.
- When cleaning the electrode rod, take care not to bend it and avoid hard knocks.

Disposal

Dispose of level electrodes in accordance with statutory waste disposal provisions.

Returning decontaminated equipment



If products have come into contact with media that are hazardous to health, they must be drained and decontaminated before being returned to GESTRA AG.

Such media include solid, liquid or gaseous substances, mixtures of these, or radiation.

GESTRA AG can accept returned products only if accompanied by a completed and signed return note and also a completed and signed declaration of decontamination.



The return confirmation and declaration of decontamination must be attached to the returned goods and be accessible from the outside. Otherwise, the goods cannot be dealt with and will be returned, carriage unpaid.

Please proceed as follows:

1. Let GESTRA AG know about the return beforehand by e-mail or phone.
2. Wait until you have received the return confirmation from GESTRA.
3. Fill out the return confirmation (and declaration of decontamination) and send it with the products to GESTRA AG.

Declaration of Conformity; Standards and Directives

You can find details on the conformity of the equipment and the applicable standards and directives in the Declaration of Conformity and associated certificates.

You can download the Declaration of Conformity from www.gestra.com and request relevant certificates by writing to the following address:

GESTRA AG

Münchener Straße 77

28215 Bremen

Germany

Tel. +49 421 3503 0

Fax +49 421 3503 393

e-mail info@de.gestra.com

Website www.gestra.com

Modifications to the equipment not approved by us will invalidate the Declarations of Conformity and certificates.



You can find our authorised agents around the world at:

www.gestra.com

GESTRA AG

Münchener Straße 77
28215 Bremen
Germany

Tel. +49 421 3503 0
Fax +49 421 3503 393
e-mail info@de.gestra.com
Website www.gestra.com

UK Importer: GESTRA UK Ltd

Unit 1 Sopwith Park, Royce Close,
West Portway Business Park, Andover,
Hampshire SP10 3TS
United Kingdom