



Level Switch

NRGS 15-1

EN
English

Original Installation Instructions
818479-06

Contents

Page

Usage for the intended purpose

Function.....	4
Safety note.....	4

Improper use

Application in potentially explosive areas.....	5
---	---

Technical Data

Level switch NRGS 15-1	6
Scope of supply	7

Example name plate / marking	8
------------------------------------	---

Dimensions.....	9
-----------------	---

Establishing Functions

Selecting function	10
Level switch NRGS 15-1	11
Establishing functions	12
Changing the time delay.....	12
Key	12
Adjusting sensitivity range.....	13

Installation

Tools	14
NRGS 15-1.....	15
NRGS 15-1, step 1	16
NRGS 15-1, step 2	16
Table "Functions".....	16
Key	16
Examples of installation	17
Key	17

Electrical connection

Level switch NRGs 15-1	18
Connecting level switch NRGs 15-1	18
Wiring diagram	19
Tools	19

Commissioning procedure

Checking electrical connection	20
Applying supply voltage	20
Checking switchpoints and functions	20
Checking switchpoints and functions	21
Checking switchpoints and functions	22

Troubleshooting

Indication, diagnosis and remedy	23
Indication, diagnosis and remedy	24
Replacing electronic module	24

Removing and disposing of the level switch

Removing and disposing of the level switch	25
--	----

Annex

Adjust other functions	26
Installation in non-metallic vessel	26

Declaration of Conformity; standards and directives.....27

Usage for the intended purpose

The level switch NRGs 15-1 is designed for detecting and signalling four different liquid levels and works for instance in condensate and feedwater tanks, steam boilers and (pressurised) hot-water installations as water level and switching controller with MIN and MAX alarm.

Function

The level switch NRGs 15-1 is a complete package consisting of a four-tipped level electrode and an integrated level switching controller. The equipment works only with water having a min. electrical conductivity of $> 0.5 \mu\text{S}/\text{cm}$ at 25°C .

A switching channel with time delay, an output relay and a signal LED are assigned to each electrode tip.

The functions of the switching channels 1 and 4 are fixed, the switching channels 2 and 3 can be adjusted via code switch to suit individual requirements. The tips of the electrode are cut to length on site in order to establish the desired switchpoints of the associated switching channels.

The following functions are possible:

- Electrode rod 1 exposed / switching channel 1 energizes relay 1 = low level 1 with optional performance test and lock-out function
- Electrode rod 2 exposed / switching channel 2 energizes relay 2 = low level 2
- Electrode rod 3 exposed or submerged / switching channel 3 energizes relay 3 in a time-controlled way = timed pump control (fill/discharge control)
- Electrode rods 2 and 3 exposed or submerged / switching channel 3 energizes relay 3 = on/off pump control (fill/discharge control)
- Electrode rod 4 submerged / switching channel 4 energizes relay 4 = high level

Safety note

The equipment must only be installed and commissioned by qualified and competent staff.

Retrofitting and maintenance work must only be performed by qualified staff who - through adequate training - have achieved a recognised level of competence.

Usage for the intended purpose - continued -



Danger

When loosening the level electrode steam or hot water might escape. This presents the danger of severe scalds to the whole body.

Do NOT remove the level switch unless the boiler pressure is verified to be 0 bar.

The level switch becomes hot during operation.

Risk of severe burns to hands and arms.

Before carrying out installation and maintenance work make sure that the equipment is cold.

The terminal strip of the level switch is live during operation.

This presents the danger of electric shock!

Always **cut off power supply** to the equipment before mounting, removing or connecting the equipment and the terminal strips!



Attention

The name plate specifies the technical features of the equipment. Do not commission or operate any item of equipment that does not bear its specific name plate.

Improper use

Application in potentially explosive areas

The equipment must **not** be used in explosion-risk areas.

Technical Data

Level switch NRGS 15-1

Service pressure

PN 25, 25 bar at 224°C

Mechanical connection

Screwed G 1A, EN ISO 228-1

Materials

Screw-in body: 1.4571, CrNiMoTi17-12-2 or 1.4404, A 470 316L for NPT thread

Electrode rods: 1.4571, CrNiMoTi17-12-2

Insulation of electrode rod: PTFE

Spacer disc: PTFE

Terminal box: Polycarbonate

Electrode rods

Length supplied: 1000 mm

Diameter: 5 mm

Supply voltage

220 – 240 V +10/–15 %, 50/60 Hz

110 – 120 V +10/–15 %, 50/60 Hz (optional)

24 V +10/–15 %, 50/60 Hz (optional)

Power consumption

3 VA

Fuse

external 63 mA, slow blow, at 230 V,

external 125 mA, slow blow, at 115 V,

external 1 A, slow blow, at 24 V.

Response sensitivity (Electrical conductivity of water at 25°C)

> 0.5 ... < 1000 µS/cm or > 10 ... < 10000 µS/cm (switch-selectable)

Electrode voltage

20 V_{ss}

Output

4 volt-free change-over contacts,

8 A 250 V AC / 30 V DC cos φ = 1 (IEC 61810)

Ensure interference suppression by providing contactor with an arc suppressor RC combination

Energizing /de-energizing delay

Relay 1 and 2: 1s, factory set

Relay 3: 0-30s, adjustable via potentiometer

Relay 4: 3s, factory set

Indicators and adjustors

3 red LEDs to indicate "Low level alarm 1 + 2 / High level".

1 yellow LED to indicate "Pump ON".

1 green LED to indicate "Power ON".

1 ten-pole code switch to select the sensitivity range and to establish the functions.

1 potentiometer for setting the time delay (0 to 30 s)

1 test button in the terminal box to check the function of switching channel 1 (connected to terminals).

1 reset button in the terminal box to reset the lock-out function (connected to terminals).

Technical Data - continued -

Level switch NRGs 15-1 - continued -

Cable entry / electrical connection

3 cable glands with integral cable clamps (M 16)

1 two-pole terminal strip for power supply.

1 twelve-pole terminal strip for connecting the control cables.

1 four-pole terminal strip for test and reset button.

Screw-type terminal strips, conductor size $\leq 1,5 \text{ mm}^2$.

Protection

IP 65 to DIN EN 60529

Protection class

2 (completely insulated)

Ambient temperature

when system is switched on: $0^\circ \dots 70^\circ\text{C}$, during operation: $-10^\circ \text{C} \dots 70^\circ\text{C}$

Transport temperature

$-20^\circ \dots +80^\circ\text{C}$ (< 100 hours), defrosting time of the de-energized equipment before it can be put into operation: 24 hours.

Storage temperature

$-20^\circ \dots +70^\circ\text{C}$, defrosting time of the de-energized equipment before it can be put into operation: 24 hours.

Relative humidity

max. 95%, no moisture condensation

Weight

approx. 1.4 kg

Scope of supply

NRGS 15-1

1 Level electrode with four tips

1 Terminal box with integrated level switch

1 Joint ring 33 x 39, form D, DIN 7603, made from 1.4301, bright annealed

1 Installation manual

or

NRGS 15-1







1 Level electrode with four tips

1 Terminal box with integrated level switch and built-in Test and Reset pushbutton

1 Joint ring 33 x 39, form D, DIN 7603, made from 1.4301, bright annealed

1 Installation manual

Example name plate / marking

 Betriebsanleitung beachten! See installation instruction!	
 Vor dem Öffnen des Deckels Gerät freischalten! Before removing cover isolate from power supplies!	
1	
2	
3	
4	5 6 7
	bar (psi) 8 °C (°F) Tamb = T °C (°F)
9	10 11
L/H= 12	19
ppm 20	µS/cm 21
22	23
24	25
26	
13	
14 UK CA	15 
16 GESTAMP Münchener Str.77 28215 Bremen Made in Germany	17 
18  12345678-12345678	

- 1** Safety note
- 2** Equipment designation
- 3** Equipment function
- 4** Nominal pressure rating
- 5** Connection thread
- 6** Material of screw-in thread
- 7** IP rating
- 8** Maximum pressure and temperature ratings
- 9** Power supply
- 10** Frequency in case of AC devices
- 11** Power consumption
- 12** Measuring range, length/height in mm
- 13** Component identification
- 14** Mark of conformity
- 15** Disposal information
- 16** Manufacturer
- 17** Protection class
- 18** Material number-serial number

Optional information

- 19** Cell constant in 1/cm
- 20** Measuring range in ppm
- 21** Measuring range in µS/cm
- 22** Hardware interface
- 23** Delay time
- 24** Additional data
- 25** Set limit with TRV (Tmax)
- 26** Cutout relay/specification of functional safety

Fig. 1



The date of production is stamped on the screw-in body of the level transmitter.

Dimensions

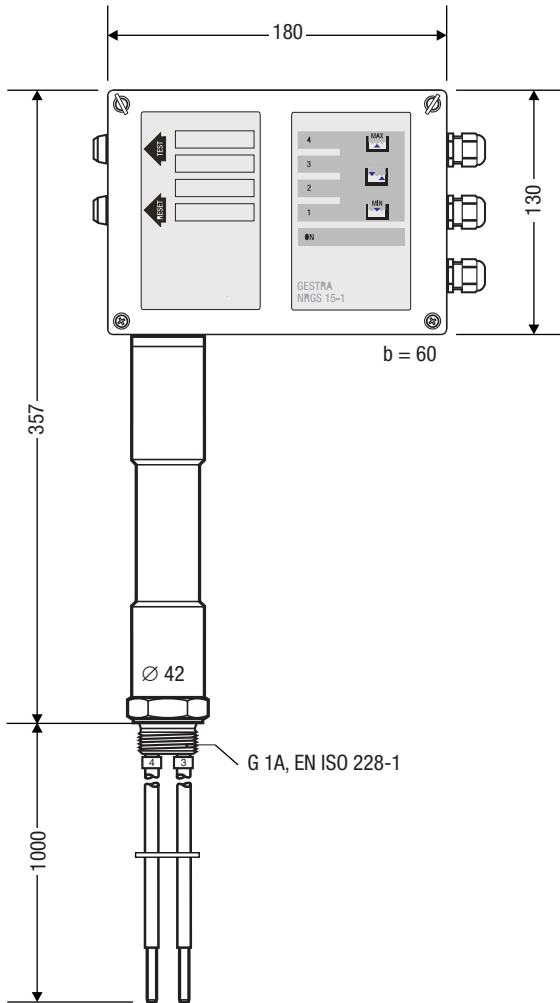

Fig. 2

Establishing Functions

Selecting function

Before installing and commissioning the NRGs 15-1 ascertain the settings for the required functions. Five functions are available:

Function 1 Default factory setting for equipment without pushbutton		Code switch Toggle switch white
Electrode rod 1	Low level 1 / burner off	
Electrode rod 2	Low level 2	
Electrode rod 3	Timed pump control (fill control) tv = 0 – 30 s	
Electrode rod 4	High water	
Function 2 Default factory setting for equipment with pushbutton		
Electrode rod 1	Low level 1 / burner off with test and reset button	
Electrode rod 2	Low level 2	
Electrode rod 3	Timed pump control (fill control) tv = 0 – 30 s	
Electrode rod 4	High water	
Function 3		
Electrode rod 1	Low level alarm 1 / burner off	
Electrode rod 2	Feed pump on (fill control)	
Electrode rod 3	Feedwater pump off (tv = 0 s)	
Electrode rod 4	High water	
Function 4		
Electrode rod 1	Low level alarm 1 / burner off with test and reset button	
Electrode rod 2	Feed pump on (fill control)	
Electrode rod 3	Feedwater pump off (tv = 0 s)	
Electrode rod 4	High water	
Function 5		
Electrode rod 1	Low level alarm 1	
Electrode rod 2	Pump off	
Electrode rod 3	Pump on (discharge control) tv = 0 s	
Electrode rod 4	High water	

Level switch NRG5 15-1

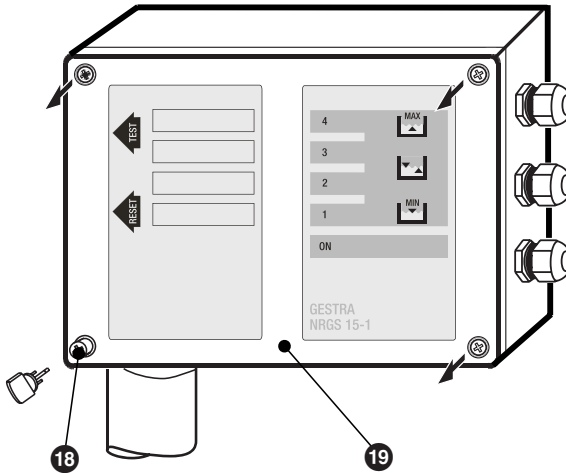

Fig. 3

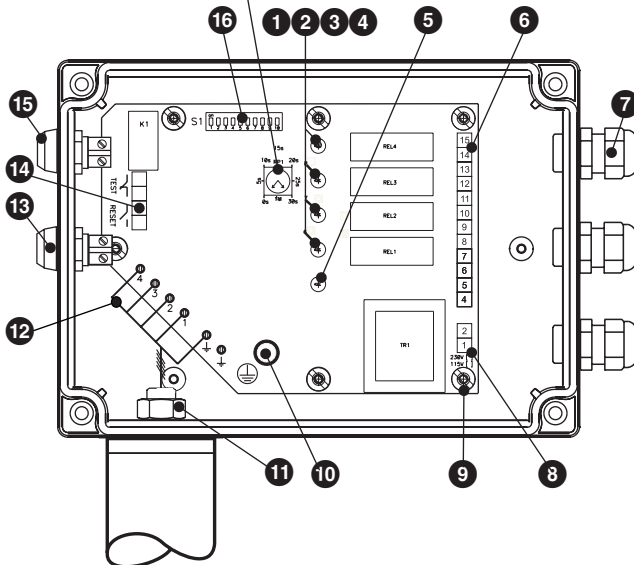
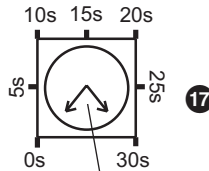

Fig. 4



Note

To set the **functions**, the **time delay** and the **response sensitivity** open the terminal box. To do so unscrew the cover screws **18** and remove the housing cover **19**. After changing the settings replace the housing cover **19** and fasten the cover screws **18**.

Establishing functions

1. Set the code switch **16** to the desired function. For this purpose you can use a screwdriver with a thin blade.
2. Use a waterproof marker to enter the established function for each electrode tip in the labelling boxes on the lid (see **Fig. 3**).

Changing the time delay

The default time delay for the pump control is 5 seconds.

1. Turn the potentiometer knob **17** to the left or right to set a time delay between 0 and 30 seconds.

Key

- | | |
|--|---|
| 1 LED 1 red | 11 Fixing nut for terminal box |
| 2 LED 2 red | 12 Terminal lugs for electrode wires, functional earth |
| 3 LED 3 amber | 13 RESET button |
| 4 LED 4 red | 14 Terminal strip for pushbuttons |
| 5 LED green for Power ON | 15 TEST button |
| 6 Terminal strip for control lines | 16 Code switch |
| 7 Cable gland 3 x M16 x 1,5 | 17 Potentiometer for time delay |
| 8 Terminal strip for supply voltage | 18 Cover screws (cross recess head screws M4) |
| 9 Fixing screws for electronic module | 19 Housing cover |
| 10 PE connection | |

Adjusting sensitivity range

The default factory setting for the response sensitivity is $\geq 10 \mu\text{S/cm}$.

If the electrical conductivity of the boiler water is below $10 \mu\text{S/cm}$ at 25°C use the code switch 16 to change the response sensitivity. To change the setting of the code switch 16 located on the electronic module (see Fig. 4) use a screwdriver with a thin blade.

The following sensitivity ranges are possible:

Code switch Toggle switch white	Sensitivity of response
<p>ON 1 2 3 4 5 6 7 8 9 10</p>	Response sensitivity $\geq 0.5 \mu\text{S/cm}$ at 25°C
<p>ON 1 2 3 4 5 6 7 8 9 10</p>	Response sensitivity $\geq 10 \mu\text{S/cm}$ at 25°C (Factory setting)

Installation



Note

- For the approval of the boiler standpipe the relevant regulations must be considered.
- Refer to page 18 for typical installation examples.



Attention

- Install the level switch only in a vertical position.
- The seating surfaces of the standpipe or the flange provided on the vessel must be accurately machined, **Fig. 6!**
- Do not bend electrode tips when mounting!
- Do not subject electrode tips to physical shocks.
- At least 30 mm of the insulating tube must remain on the electrode tips.
- Use only the supplied joint ring!
33 x 39, form D, DIN 7603, 1.4301, bright annealed
- Do not lag electrode body above the hexagonal section!
- Do not lag the electrode body above the hexagonal part!
- Note that the max. thermal insulation of the boiler is 40 mm (see **Fig. 5**).
- Do not insulate electrode thread with hemp or PTFE tape!
- Do not apply conductive paste or grease to the electrode thread!
- Make sure that the air distance between the electrode tips and earth (flange, vessel wall) is not less than 14 mm! **Fig. 7, 8**
- Observe the minimum distances for the installation of the electrode!
- The specified torques must be strictly observed.

Tools

- Open-end spanner A.F. 41, DIN 3110, ISO 3318
- Scriber
- Bolt cutter
- Flat file, medium cut 2, DIN 7261, form A
- Screwdriver, size 2
- Screwdriver, size 2.5, completely insulated according to EN IEC 60900

NRGS 15-1

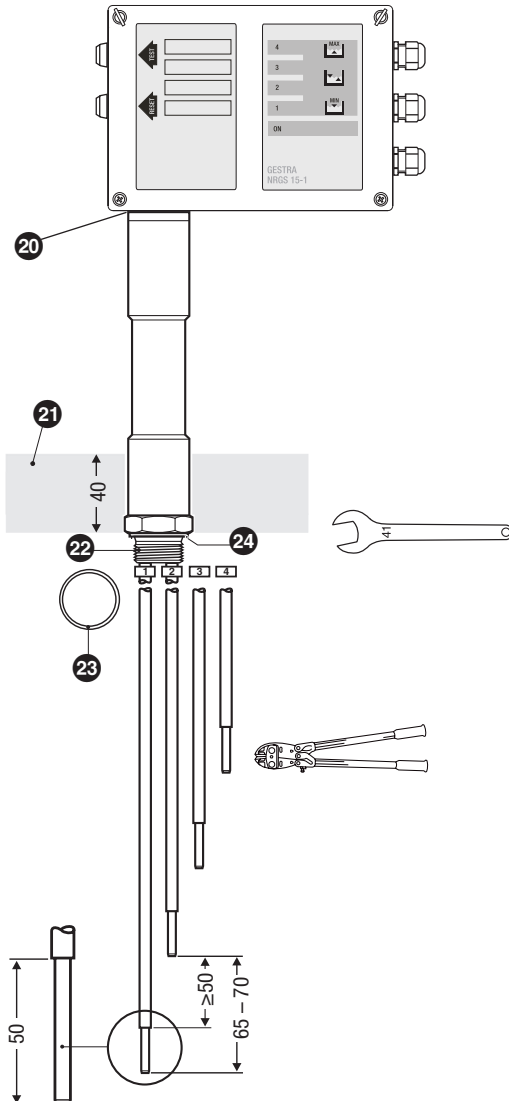

Fig. 5

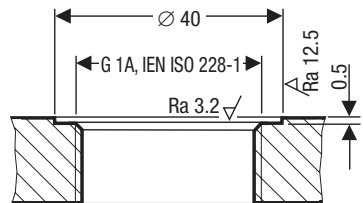

Fig. 6

NRGS 15-1, step 1

1. Determine the measuring lengths of the electrode tips and enter the lengths in the **table "Functions"**.
2. Cut the electrode tips **1** **2** **3** **4** to lengths with a bolt cutter.
3. Deburr the end faces of the electrode tips.
4. Strip off 50 mm of PTFE insulation from the ends of the electrode tips. Make sure that the remaining insulation is at least 30 mm long, measured from the lower edge of the screwed connection.
5. Position the PTFE spacer discs evenly to support the tips.

NRGS 15-1, step 2

6. Check the sealing surfaces. **Fig. 6**
7. Place supplied joint ring **20** onto seating surface of the threaded standpipe or flange. **Fig. 6**
8. Apply a light smear of heat resistant silicone grease (e.g. WINIX® 2150) to electrode thread **22**.
9. Screw the level switch into the threads or flange and tighten with a 41 mm open-end spanner. The torque required **when cold is 160 Nm**.
10. Insulate the boiler at the area where the level switch is installed, making sure that the thickness of insulation does not exceed 40 mm (see **Fig. 5**).

Table "Functions"

Electrode tip	Function	Wire/ connector	Length [mm]
1		1	
2		2	
3		3	
4		4	

Key

- 20** Gasket
- 21** Thermal insulation, provided on site, d = 40 mm (outside of thermal insulation of steam boiler)
- 22** Screwed G 1A, EN ISO 228-1
- 23** Joint ring 33 x 39, form D, DIN 7603, 1.4301, bright annealed
- 24** Seating surface

Examples of installation

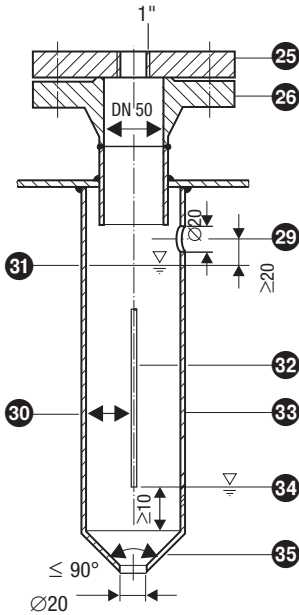

Fig. 7

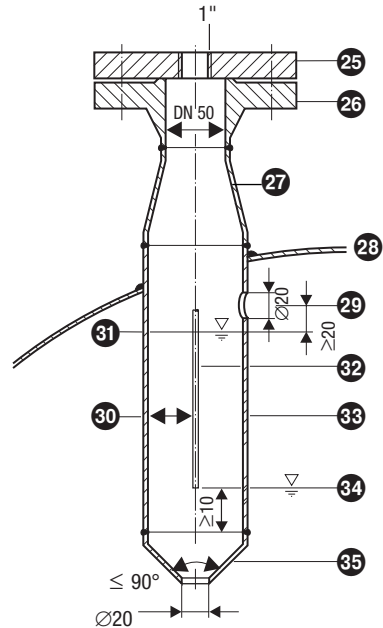

Fig. 8

Key

- 25 Flange PN 40, DN 50, DIN EN 1092-01 or flange PN 40, DN 100, DIN EN 1092-01
- 26 For the approval of the boiler standpipe with connecting flange the relevant regulations must be considered.
- 27 e. g. reducer DIN 2616-2, K-88.9 x 60.3 x 3.2 DIN 2616
- 28 Boiler wall
- 29 Vent hole
Provide vent hole as close to the boiler wall as possible!
- 30 Electrode distance ≤ 14 mm (air gap and creepage distance)
- 31 High water HW
- 32 Electrode rods
- 33 Protection tube DN 80
- 34 Low water LW
- 35 Reducer DIN 2616-2, K-88.9 x 3.2-42.4 x 2.6 W
- 18 Cover screws (cross recess head screws M4)
- 19 Housing cover
- 6 Terminal strip for control lines
- 7 Cable gland 3 x M16 x 1,5
- 8 Terminal strip for supply voltage
- 9 Fixing screws for electronic module
- 10 PE connection
- 11 Fixing nut for terminal box

Electrical connection

Level switch NRG5 15-1

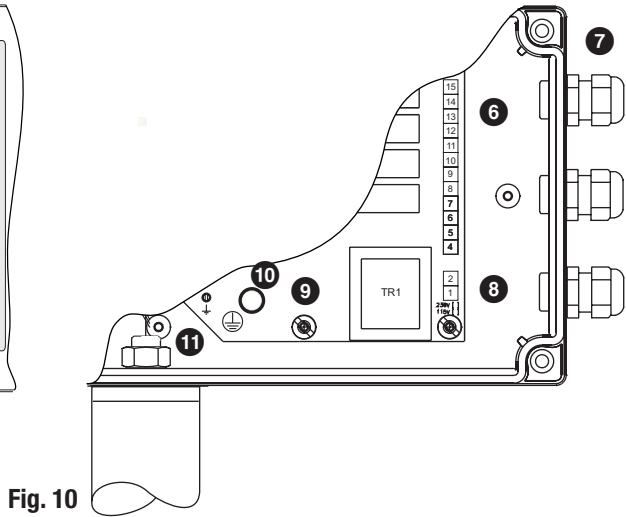
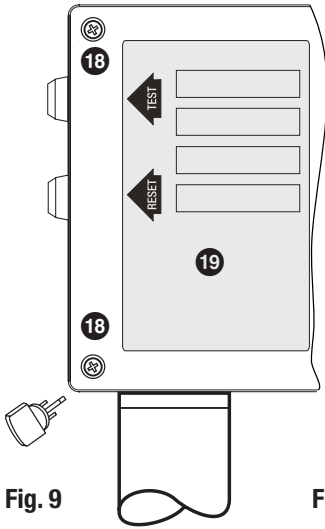

Fig. 9

Fig. 10

Aligning terminal box

A self-locking fixing nut (13) connects the terminal box to the electrode part. Before establishing the electrical connection you can turn the terminal box through max. +/- 180° into the desired direction (cable gland).

Connecting level switch NRG5 15-1

1. Undo the cover screws (18) and remove the housing lid (19). **Fig. 3, 9**
2. Detach the terminal strips (6) and (8) from the electronic module.
3. Strip off approx. 40 mm of cable insulation coating and remove approx. 5 mm of conductor end insulation.
4. Loosen cable glands (7) and run the mains cable through the lower cable gland and the control cable through the upper cable gland.
5. Connect the mains and control cables according to the wiring diagram **Fig. 11** (inside of housing lid) to the terminal strips (6) and (8).
6. Plug the terminal strips (6) and (8) onto the electronic module.
7. Retighten the cable glands (7).
8. Put the housing lid (19) back on and fasten the cover screws (18).

Electrical connection

- continued -

Wiring diagram

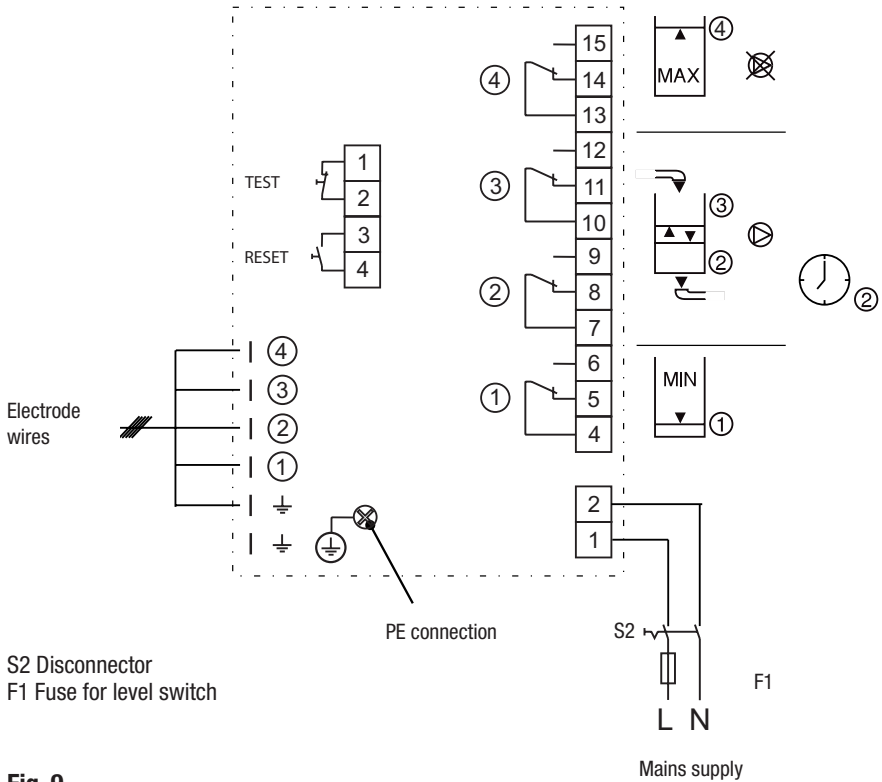

Fig. 9

Tools

- Screwdriver, size 2
- Screwdriver, size 2.5, completely insulated according to EN IEC 60900

Electrical connection

- continued -



Attention

- The following relocations of cables with basic insulation are not permissible:
Mains and control cables in low voltage areas.
- To prevent the welding together of contacts provide an external slow-blow fuse T 2.5 A for the output contacts..
- When switching off inductive loads, voltage spikes are produced that may impair the operation of control and measuring systems. Connected inductive loads must be provided with suppressors such as RC combinations as specified by the manufacturer.
- Provide the level switch with an external slow-blow fuse: 63 mA at 230 V, 125 mA at 115V or 1A at 24 V.
- For disconnecting the level switch install an easily accessible disconnecter in the close proximity of the equipment (EN 61010-1).
- Mark the disconnecter as isolating device for the conductivity switch.

Commissioning procedure



Danger

To commission the equipment switch water level control system to manual operation. Make sure that installation is in manual operation mode when you fill or discharge the steam boiler or vessel.

Checking electrical connection

1. Make sure that the level switch is wired as specified in the wiring diagram. **Fig. 9**
2. Make sure that the supply voltage agrees with the specification on the name plate.

Applying supply voltage

1. Apply mains voltage. The green LED ⑤ for Power ON lights up.
The LEDs ①, ②, ③, ④ **Fig. 4** are lit as a function of the water level.

Checking switchpoints and functions

1. To check the switchpoints and their correct functioning fill or empty the tank accordingly. See table **Checking switchpoints and functions on** pages 22 and 23.

Commissioning procedure - continued -

Checking switchpoints and functions



Danger

The terminal strip of the level switch is live during operation.

This presents the danger of electric shock!

Always **cut off power supply** to the equipment before mounting, removing or connecting the equipment and the terminal strips!

Start		
Activity	Display	Function
Switch on supply voltage.	LED ON illuminated	
	LEDs ①, ②, ③, ④ are lit as a function of the water level.	
MIN (low water) level = electrode rod 1		
Lower water level until it is below MIN level. Electrode rod 1 emerges	LED 1 illuminated red:	After 1 sec.: MIN output contact 4/5 closed, 4/6 open.
Fill vessel until MIN level is exceeded. Electrode rod 1 enters the liquid	LED 1 not illuminated	After 1 sec.: MIN output contact 4/5 open, 4/6 closed.
MIN (low water) level = electrode rod 1 with test and reset function		
Press TEST button	LED 1 illuminated red:	After 1 sec.: MIN output contact 4/5 closed, 4/6 open and disconnection interlocked
Hold down button RESET for 3 sec.	LED 1 not illuminated	After 1 sec.: MIN output contact 4/5 open, 4/6 closed.
Lower water level until it is below MIN level. Electrode rod 1 emerges	LED 1 illuminated red:	After 1 sec.: MIN output contact 4/5 closed, 4/6 open and disconnection interlocked
Fill vessel until MIN level is exceeded. Electrode rod 1 enters the liquid. Hold down button RESET for 3 sec.	LED 1 not illuminated	After 1 sec.: MIN output contact 4/5 open, 4/6 closed.
MIN (low water) level 2 = electrode rod 2		
Lower water level until it is below MIN (low water) level 2. Electrode rod 2 emerges	LED 2 illuminated red:	After 1 sec.: MIN output contact 7/8 closed, 7/9 open.
Fill vessel until MIN level 2 is exceeded. Electrode rod 2 enters the liquid	LED 1 not illuminated	After 1 sec.: MIN output contact 7/8 open, 7/9 closed.
MAX (high water) level = electrode rod 4		
Fill vessel until MAX level is exceeded. Electrode rod 4 enters the liquid	LED 4 illuminated red:	After 3 sec.: MIN output contact 13/14 closed, 13/15 open.
Lower water level until it is below MAX level. Electrode rod 4 emerges	LED 4 not illuminated	After 3 sec.: MIN output contact 13/14 open, 13/15 closed.

Checking switchpoints and functions

Timed pump control (fill control) = electrode tip 3		
Activity	Display	Function
Lower water level until it is below the switchpoint "Pump ON". Electrode rod 3 emerges	LED 3 illuminated amber	Pump output contact 10/12 closed, 10/11 open.
Fill vessel until switchpoint "Pump OFF" is exceeded. Electrode rod 3 enters the liquid	LED 3 not illuminated	After the adjusted time delay (0-30s): Pump output contact 10/12 open, 10/11 closed.
Relay 3 is de-energized too early or too late: Increase or decrease time delay with the aid of the potentiometer and let electrode tip 3 emerge or enter the liquid again. Repeat the process until you have found the correct switchpoint for the pump. If 30 sec. time delay is not enough for filling the boiler, select the operating mode "on-off pump control".		

ON/off pump control (fill control) = electrode rod 2 and 3		
Set potentiometer for time delay to 0 sec.		
Lower water level until it is below the switchpoint "Pump ON". Electrode rods 2 and 3 exposed.	LEDs 2 and 3 are illuminated	Pump output contact 10/12 closed, 10/11 open.
Fill vessel until switchpoint "Pump ON" is exceeded. Electrode rod 2 enters the liquid	LED 2 not illuminated	
Fill vessel until switchpoint "Pump OFF" is exceeded. Electrode rod 3 enters the liquid	LED 3 not illuminated	Pump output contact 10/12 open, 10/11 closed.
Electrode rods 2 and 3 = on-off pump control (discharge control)		
Set potentiometer for time delay to 0 sec.		
Fill vessel until switchpoint "Pump ON" is exceeded. Electrode rods 2 and 3 submerged.	LED 2 not illuminated, LED 3 illuminated	Pump output contact 10/12 closed, 10/11 open.
Lower water level until it is below the switchpoint "Pump ON". Electrode rod 3 emerges.	LED 3 not illuminated	
Lower water level until it is below the switchpoint "Pump OFF". Electrode rod 2 emerges.	LED 2 illuminated	Pump output contact 10/12 open, 10/11 closed.

Troubleshooting

Indication, diagnosis and remedy



Attention

Before carrying out the fault diagnosis please check:

Supply voltage:

Is the equipment supplied with the mains voltage specified on the name plate?

Wiring:

Is the wiring in accordance with the wiring diagram?

Switchpoint MIN (low water) level		
Status and indication	Error	Remedy
Water level below MIN switchpoint, LED 1 not illuminated.	Electrode rod is too long.	Cut electrode rod to the length dictated by the switchpoints.
	Electrode rod has earth contact.	Check and, if necessary, change position of installation.
	If installed inside the boiler: Upper vent hole in protection tube does not exist or is obstructed.	Check installation of level switch. Make sure that the level in the protection tube corresponds to the actual water level.
MIN switchpoint reached, LED 1 illuminated red.	Electrode rod is too short.	Replace level switch and cut electrode rods to the length dictated by the switchpoints.
	The earth connection to the vessel is interrupted.	Clean seating surfaces and screw level switch together with metal joint ring in place. Do not insulate the electrode with hemp or PTFE tape!
	Electrical conductivity of the boiler water too low.	Change response sensitivity to 0,5 µS/cm.
	Upper vent hole flooded.	Check installation of level switch. Make sure that the level in the protection tube corresponds to the actual water level.

Switchpoint MAX (high water) level		
Status and indication	Error	Remedy
Water level below MAX switchpoint, LED 4 illuminated red.	Electrode rod is too long.	Cut electrode rod to the length dictated by the switchpoints.
	Electrode rod has earth contact.	Check and, if necessary, change position of installation.
	If installed inside the boiler: Upper vent hole in protection tube does not exist or is obstructed.	Check installation of level switch. Make sure that the level in the protection tube corresponds to the actual water level.
MAX switchpoint reached, LED 4 not illuminated.	Electrode rod is too short.	Replace level switch and cut electrode rods to the length dictated by the switchpoints.
	The earth connection to the vessel is interrupted.	Clean seating surfaces and screw level switch together with metal joint ring in place. Do not insulate the electrode with hemp or PTFE tape!
	Electrical conductivity of the boiler water too low.	Change response sensitivity to 0,5 µS/cm.
	Upper vent hole flooded.	Check installation of level switch. Make sure that the level in the protection tube corresponds to the actual water level.

Indication, diagnosis and remedy

Switchpoint has been reached - incorrect function		
Status and indication	Error	Remedy
Incorrect function when switchpoint is reached	The electrode tips have been cut to the wrong length.	Assign the electrode rods correctly and change connections on the electronic module.
	The code switch setting is incorrect.	Set code switch according to the selected function.

Level switch is not working		
No supply voltage. LED Power ON not illuminated	No supply voltage.	Switch on supply voltage. Check all electrical connections.
No function.	The earth connection to the vessel is interrupted.	Clean seating surfaces and screw level switch together with metal joint ring in place. Do not insulate the electrode with hemp or PTFE tape!
	Electronic module defective.	Replace electronic module.

Replacing electronic module

Before exchanging the electronic module take the level switch out of service and cut off its voltage supply.

- Undo the cover screws **18** and remove the housing lid **19**. (Fig. 3, 4)
- Pull the electrode wires off the terminal lugs **12** on the electronic insert.
Unplug all terminal strips **6**, **8**, **14**.
- Undo the PE connection **10**.
- Unscrew the fixing screws **9** of the electronic module and take out the electronic module. The module is available as spare part.

Stock code #	NRGS 15-1
321357	NRV 1-47 230 V AC

- Install the new electronic module in reverse order.



Note

When ordering spare parts please state the material number indicated on the name plate. After replacing the electronic module please re-commission the equipment.

Removing and disposing of the level switch



Danger

When loosening the level electrode steam or hot water might escape. This presents the danger of severe scalds to the whole body.

Do NOT remove the level switch unless the boiler pressure is verified to be 0 bar.

The level switch becomes hot during operation.

Risk of severe burns to hands and arms.

Before carrying out installation and maintenance work make sure that the equipment is cold.

The terminal strip of the level switch is live during operation.

This presents the danger of electric shock!

Always **cut off power supply** to the equipment before mounting, removing or connecting the equipment and the terminal strips!

Removing and disposing of the level switch

Before removing the level switch take it out of service and cut off its voltage supply.

1. Undo the cover screws **18** and remove the housing lid **19**. (**Fig. 3, 4**)
2. Detach the connecting wires from the terminal strips **6**, **8** and pull the wires out of the cable glands.
3. Undo the PE connection **10**.
4. Before removing the level switch make sure that it is neither hot nor under pressure.

For the disposal of the equipment observe the pertinent legal regulations concerning waste disposal.

If faults occur that are not listed above or cannot be corrected, please contact our service centre or authorized agency in your country.







Annex

Adjust other functions

The level switch assigns one switching channel to each electrode tip. The functions of the switching channels 1 and 4 are fixed, the switching channels 2 and 3 can be adjusted via code switch 16 to suit individual requirements.

The assigned electrode tip is cut to length on site in order to establish the level-dependent switchpoint of each individual switching channel.

The code switch can also be used to establish other functions than the ones described in the section "Establishing Functions".

Code switch Toggle switch white	Function
	No TEST button
	No RESET button
	On-off pump control switched on
	Electrode rod 2 separated from electrode rod 1
	Pump fill control switched on
or	
	Pump discharge control switched on

Installation in non-metallic vessel

The level switch can also be installed in non-metallic vessels.

Provided that the function "High level alarm" is not used the electrode rod 4 can be used as reference electrode.

For this purpose plug the connection of the electrode rod 4 into the free terminal lug for the functional earth 12.

In addition, cut the electrode rod 4 to the same length as electrode rod 1 and strip off the whole insulation.

Declaration of Conformity; Standards and Directives

You can find details on the conformity of the equipment and the applicable standards and directives in the Declaration of Conformity and associated certificates.

You can download the Declaration of Conformity from www.gestra.com and request relevant certificates by writing to the following address:

GESTRA AG

Münchener Straße 77

28215 Bremen

Germany

Tel. +49 421 3503 0

Fax +49 421 3503 393

E-mail info@de.gestra.com

Website www.gestra.com

Modifications to the equipment not approved by us will invalidate the Declarations of Conformity and certificates.



Agencies all over the world: www.gestra.com

GESTRA AG

Münchener Straße 77
28215 Bremen
Germany

Telefon +49 421 3503-0
Telefax +49 421 3503-393
E-mail info@de.gestra.com
Web www.gestra.com

UK Importer: GESTRA UK Ltd

Unit 1 Sopwith Park, Royce Close,
West Portway Business Park, Andover,
Hampshire SP10 3TS
United Kingdom