

Swing Check Valve

CB 14

CB 24S

CB 26

CB 26A

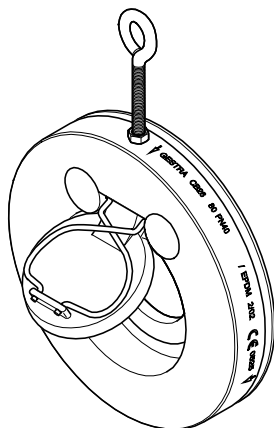
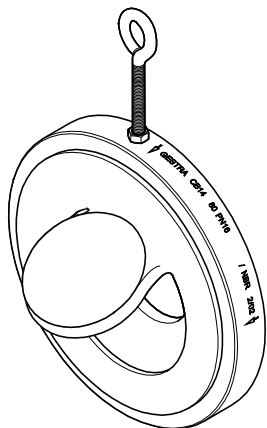

Contents

Foreword	3
Availability	3
Formatting features in the document	3
Safety	3
Use for the intended purpose	3
Basic safety notes	4
Typographic features of warning notes	5
Formatting features for warnings of property damage	5
Description	6
Scope of supply and equipment specification	6
Application of European Directives	7
Task and function	7
End connections	8
Storing and transporting the equipment	8
Storing the equipment	8
Transporting the equipment	8
Mounting and connecting the equipment	9
Preparing installation	9
Mounting the equipment	9
Operation	12
After operation	12
Removing external dirt deposits	12
Maintaining the equipment	13
Servicing the equipment and installing spare parts	13
Troubleshooting	16
Putting the equipment out of operation	17
Removing harmful substances	17
Removing the equipment	17
Re-using equipment after storage	18
Disposing of the equipment	18
Technical data	20
Dimensions and weights	20
Pressure & temperature ratings	22
Manufacturer's declaration	23

Foreword

This installation & operating manual will help you use the following types of equipment safely and efficiently for their intended purpose.

- ▶ Swing check valve CB 14 (steel)
- ▶ Swing check valve CB 24S (bronze)
- ▶ Swing check valve CB 26 (carbon steel)
- ▶ Swing check valve CB 26A (stainless steel)

These types will be called equipment in this document.

This installation & operating manual is intended for anyone commissioning, using, operating, servicing, cleaning or disposing of this equipment and, in particular, for professional after-sales service technicians, qualified personnel and authorised and trained staff.

All of these persons must read and understand the content of this installation & operating manual.

Following the instructions given in this installation & operating manual helps avoiding danger and increases the reliability and service life of the equipment. Please note that in addition to the instructions given in this installation & operating manual you must also observe all locally applicable rules and regulations concerning the prevention of accidents as well as approved safety guidelines for good professional practice.

Availability

Keep this installation & operating manual together with the plant documentation for future reference. Make sure that this installation & operating manual is available to the operator.

The installation & operating manual is part of the equipment. Please hand over this installation & operating manual when selling the equipment or passing it on.

Formatting features in the document

Certain text elements of this installation & operating manual feature a specific typographic design. You can easily distinguish the following text elements:

Standard text

Cross-reference

- ▶ Listing
 - ▶ Sub-items in listings
- Steps for action.



Here you will find additional useful information and tips serving to assist you in using the equipment to its fullest potential.

Safety

Use for the intended purpose

Swing check valves ensure unidirectional flow in pipes by preventing a backflow of liquids or gases.

The equipment must only be used within the allowable pressure and temperature limits and only if the chemical and corrosive influences on the equipment are taken into account.

Correct use includes compliance with the instructions given in this installation & operating manual, in particular obedience to all safety instructions.

Any other use of the equipment is considered to be improper.

Note that the equipment must not be installed in pipes where the fluid is delivered by a piston pump or compressor.

Furthermore the equipment must not be used as end-of-line valve or as item of equipment with safety function.

The equipment is also used improperly if the materials of the equipment are not suitable for the intended service conditions.

Basic safety notes

Risk of severe injuries

- ▶ The equipment is under pressure and hot during operation. Before carrying out any work on the equipment make sure that the following requirements are met:
 - ▶ The pipes must be depressurized (0 bar).
 - ▶ The fluid must be completely removed from the pipes and the equipment.
 - ▶ During work on the equipment the installation must be switched off and protected against unauthorised or unintended activation.
 - ▶ The pipes and the equipment must have cooled down to room temperature (approx. 20 °C).
- ▶ If the equipment is used in contaminated areas there is a risk of severe injuries or death caused by harmful substances in or on the equipment. Before working on the equipment make sure that it is completely decontaminated. Always wear the protective clothing prescribed for contaminated areas when working on the equipment.
- ▶ The equipment must only be used with fluids that do not attack the material and the gaskets and sealings of the equipment. Otherwise leaks may occur and hot or toxic fluid could escape.
- ▶ The equipment and its component parts must only be mounted or removed by qualified personnel. A qualified person must be acquainted with and experienced in the following:
 - ▶ Making pipe connections.
 - ▶ Working with dangerous (contaminated, hot or pressurized) fluids.
- ▶ If installation or removal work is carried out carelessly the springs may shoot out of the body and injure personnel.
Always wear safety goggles when mounting or removing the springs.
When working on the springs make sure that no uninvolved persons are standing in close vicinity of the equipment.

Risk of minor injuries

- ▶ Sharp edges on internals present the danger of cuts to hands. Always wear industrial gloves when servicing the equipment.
- ▶ If the support of the equipment during installation is insufficient the equipment might fall down, thereby causing bruises or injuries. Make sure the equipment is safely held in place during installation and cannot fall down. Wear protective safety footwear.

Information on property damage or malfunctions

- ▶ Malfunctions will occur if the equipment is installed in a wrong position or with the flow pattern in the opposite direction of the fluid flow. This may result in damage to the equipment or the installation. Make sure that the flow pattern indicated on the name plate matches the direction of the fluid flow in the pipe.
- ▶ If the material is unsuitable for the fluid, increased wear may occur and fluid may escape. Make sure that the material is suitable for the fluid used in your installation.
- ▶ The equipment may get damaged by pressure impulses, even if the admissible nominal pressure PN is not exceeded. Make sure that the equipment is not subject to pressure impulses or heavily pulsating flow.

Typographic features of warning notes



DANGER

Notes with the heading DANGER warn against imminent dangerous situations that can lead to death or serious injuries.



WARNING

Notes with the heading WARNING warn against possibly dangerous situations that could lead to death or serious injuries.



CAUTION

Notes with the heading CAUTION warn against dangerous situations that could lead to minor or moderate injuries.

Formatting features for warnings of property damage

Attention!

This information warns of a situation leading to property damage.

Description

Scope of supply and equipment specification

Scope of supply

Our equipment is delivered packed and ready for assembly.

Equipment specification

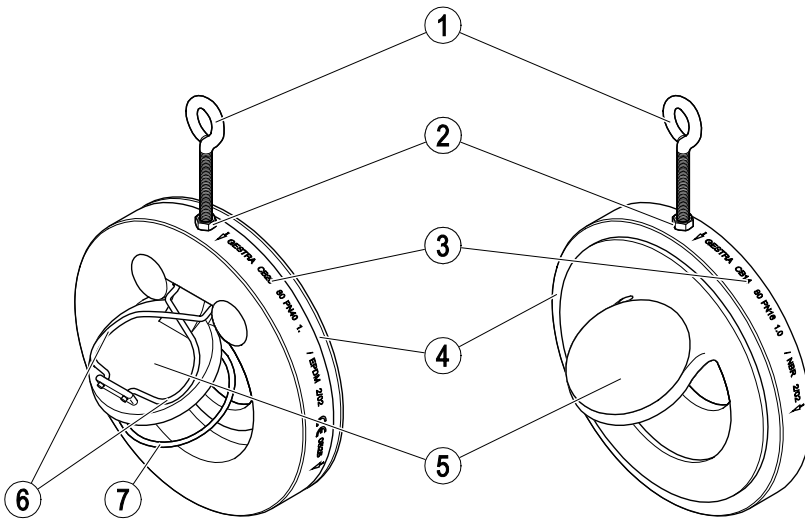

No.	Designation
1	Eye bolts for mounting
2	Locknut
3	Name plate with flow direction arrow
4	Body

No.	Designation
5	Valve disk
6	Spring (only CB 2x)
7	Spring (only CB 2x)

Name plate

The indications on the name plates vary according to the equipment type.

The name plate may specify the following:

- ▶ Type designation
- ▶ Nominal size
- ▶ Pressure rating
- ▶ Manufacturer
- ▶ Manufacturing date (quarter/year)
- ▶ Material
- ▶ Direction of flow



Equipment of type CB 14 DN40–200 has the technical specification embossed on its body.

Application of European Directives

Pressure Equipment Directive

The equipment conforms to this directive (see "Manufacturer's Declaration" section) and can be used for the following media:

CB 14, CB 24S:

- ▶ Fluids of group 2

CB 26, CB 26A:

- ▶ Fluids of group 1
- ▶ Fluids of group 2

ATEX Directive

The equipment does not have its own potential ignition source and is not subject to this directive (see "Manufacturer's Declaration" section).

When installed, static electricity may arise between the equipment and the connected system.

When used in potentially explosive atmospheres, the plant manufacturer or plant operator is responsible for discharging or preventing possible static charge.

If it is possible for medium to escape, e.g. through actuating mechanisms or leaks in threaded joints, the plant manufacturer or plant operator must take this into consideration when dividing the area into zones.

Task and function

The equipment prevents the backflow of liquids or gases in pipes.

The one-piece valve disk opens and closes as a function of the flow direction of the fluid in the pipe, thereby ensuring unidirectional flow.

Equipment of type CB 14 is opened and closed solely by the pressure of the fluid.

The standard version of the following equipment is fitted with a spring the force of which keeps the swing disk in the closed position.

- ▶ CB 24S
- ▶ CB 26
- ▶ CB 26A

These types of equipment are also available without springs.

The equipment can be installed in horizontal and vertical pipes.

If the equipment is mounted in a vertical pipe the flow must always be from bottom to top.

End connections

Equipment types CB 14 and CB 24S are designed to be sandwiched between flanges according to the following standards:

- ▶ EN 1092 PN 6/10/16
- ▶ ASME B 16.1 Class 125 FF and ASME B 16.5 Class 150 RF

Equipment types CB 26 and CB 26A are designed to be sandwiched between flanges according to the following standards:

- ▶ EN 1092 PN 6/10/16/25/40
- ▶ ASME B 16.1 Class 125 FF and ASME B 16.5 Class 150/300 RF

Storing and transporting the equipment

Attention!

Equipment can be damaged if stored or transported improperly.

- Protect the equipment against moisture and corrosive atmospheres.
- Please contact the manufacturer if you cannot comply with the recommended storage and/or transport conditions.

Storing the equipment

Please observe the following items when storing the equipment:

- ▶ Do not store the equipment for more than 12 months.
- ▶ Protect the sealing surfaces and contact areas against mechanical damage.
- ▶ Protect the equipment and all components against hard shocks and impacts.
- ▶ Store the equipment only in closed rooms that meet the following environmental conditions:
 - ▶ Air humidity below 50 %, not condensing
 - ▶ Indoor air: clean, salt-free and non-corrosive
 - ▶ Temperature 5–40 °C.
- Make sure that all these requirements are always met when storing the equipment.
- Please contact the manufacturer if you cannot comply with the recommended storage conditions.

Transporting the equipment

- Meet the requirements for storage also when transporting the equipment.
- For short distances (only a few metres) you can transport the equipment unpacked.
- When transporting the equipment over larger distances use the original packaging.
- If you do not have the original packaging use a box that protects the equipment adequately against corrosion and physical damage.



For a short period of time the equipment may be transported even if the temperature is below 0 °C, provided that the equipment is completely empty and dry.

Mounting and connecting the equipment

Preparing installation

- Take the equipment out of the transport packaging.
- Check the equipment for transport damage.
- Contact the manufacturer if you detect any kind of shipping damage.



DANGER

Personnel working on pipes are exposed to safety risks and may suffer severe injuries, poisoning or even loss of life.

- Make sure that no hot or hazardous fluid is in the equipment or the pipes.
- Make sure that the pipes upstream and downstream of the equipment are depressurised.
- Make sure that the installation is switched off and protected against unauthorised or unintended activation.
- Make sure that the equipment and the pipes have cooled down to room temperatures.
- Wear protective clothing that is suitable for the fluid and, if necessary, wear protective gear.

For more information on suitable safety clothing and safety gear refer to the safety data sheet of the fluid in question.

- Drain pipes until they are empty.
- Switch the installation off and protect it against unauthorised or unintended re-activation.

Mounting the equipment

Attention!

Equipment will be damaged if the end connections are undersized.

- Make sure that the connections are strong and rigid enough to support the weight of the equipment and to withstand the forces that occur during operation.

- Make sure that the pipe system of the plant is clean.
- Make sure that the equipment is free from foreign matter.
- Ensure that all joint faces and sealing surfaces are clean.
- Make sure that the equipment is safely mounted and that all connections are made correctly.
- Make sure that the equipment is only operated within the admissible service range and limits.

The equipment can be installed in horizontal or vertical pipes. There is no significant difference in the installation work.

The equipment can also be installed in pipes with bends. In this case you have to install the equipment downstream of the pipe bend.

A straight distance of at least five times the nominal pipe diameter for stabilizing the flow pattern must be left upstream of the equipment.

Attention!

Malfunctions may occur if the stabilizing distance is not sufficient.

- Make sure that the distance between the pump and the equipment is enough to provide a stabilized flow pattern.

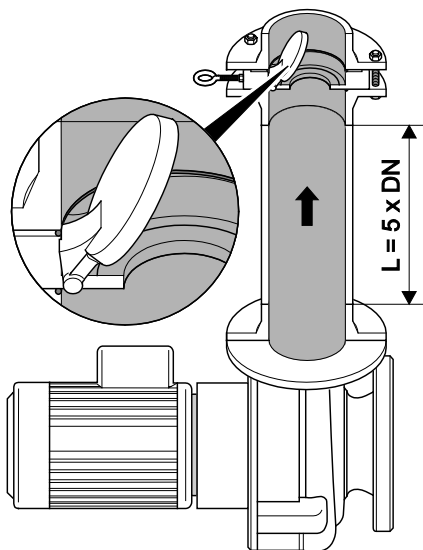

Attention!

If the installation position is incorrect malfunctions may occur and/or the equipment or the installation may get damaged.

- Make sure that the equipment is installed in the correct position.
- Always mount the equipment downstream of a pipe bend.
- When installing the equipment make sure that the eye bolt points towards the inside of the pipe bend.

The correct position of installation is indicated by the position of the eye bolt and the flow arrow on the nameplate.

If the equipment is installed in a vertical pipe the flow arrow must point upwards.

Installing the equipment with vertical direction of flow



DANGER

Incorrectly connected equipment can cause fatal accidents or severe injuries.

- Make sure that only qualified skilled personnel connect the equipment to pipes.
- Make sure that the flow arrow on the equipment body matches the direction of flow in the pipe.

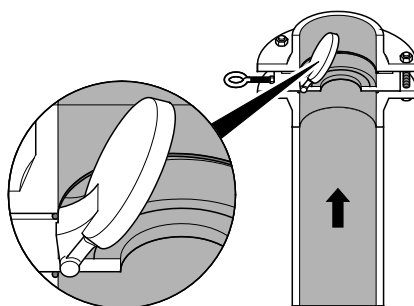

Specialist personnel must be highly qualified and fully experienced in making pipe connections for the respective type of end connection.

If the equipment is installed downstream of a pipe bend the eye bolt must point towards the inside of the pipe bend.

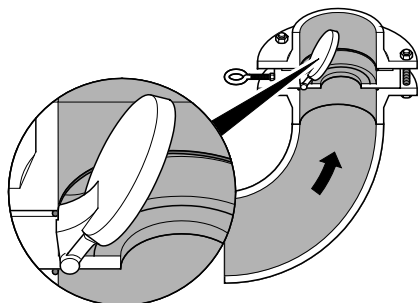

- Put a commercially available gasket that is suitable for the pipe onto the lower flange.
- Put the equipment onto the gasket.
- Put a commercially available gasket that is suitable for the pipe onto the equipment.
- Put the upper flange onto it.
- Insert all bolts through the holes in the flange.
- Make sure that all component parts are in central alignment with each other.
- Screw the nuts onto the bolts.



To obtain the desired position of installation you can turn the equipment with the eye bolt.

- Turn the equipment into the desired installation position.
- Tighten the nuts on the bolts evenly.



The torque required for tightening the nuts depends on the pipe.

Installing the equipment with horizontal direction of flow



DANGER

Incorrectly connected equipment can cause fatal accidents or severe injuries.

- Make sure that only qualified skilled personnel connect the equipment to pipes.
- Make sure that the flow arrow on the equipment body matches the direction of flow in the pipe.

Specialist personnel must be highly qualified and fully experienced in making pipe connections for the respective type of end connection.

Attention!

If the installation position is incorrect malfunctions may occur and/or the equipment or the installation may get damaged.

- Make sure that the equipment is installed in the correct position.
- When installing the equipment make sure that the eye bolt points upwards.

The correct position of installation is indicated by the position of the eye bolt and the flow arrow on the nameplate.

If the equipment is installed in a horizontal pipe the eye bolts must point upwards.

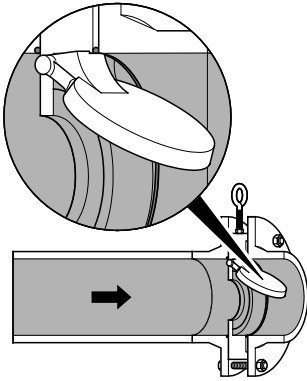

i If the equipment is installed in horizontal position you can use the lower bolts as support for the equipment.

- First insert the lower bolts through the holes in the flange.
- Then insert the two lower bolts into the second flange.
- Put two commercially available gaskets that are suitable for the pipe between the flanges.
- Put the equipment between the gaskets.
- Make sure that all component parts are in central alignment with each other.
- Insert the upper bolts.
- Align the equipment so that the eye bolt points upwards.
- Tighten the nuts on the bolts evenly.

i The torque required for tightening the nuts depends on the pipe.

Operation

Do not work on the equipment while it is operating.

After operation



DANGER

If fluid escapes personnel may suffer severe injuries, poisoning or even loss of life.

- After working on the equipment make sure that all connections and valves are tight.
- Make sure that the gaskets of the body are leakproof.



DANGER

If the equipment is used in contaminated areas there is a risk of severe injuries or death caused by harmful substances in or on the equipment.

- Only qualified personnel are allowed to perform work on contaminated equipment.
- Always wear the protective clothing prescribed for contaminated areas when working on the equipment.
- Make sure that the equipment is completely decontaminated before carrying out any service work.
- Follow the pertinent instructions for handling the hazardous substances in question.

Removing external dirt deposits

- To remove dirt deposits rinse the equipment with fresh water and wipe it with a clean, lint-free cloth.
- To remove any persistent residues use a cleaning agent that is suitable for the material and carefully wipe the equipment with a clean, lint-free cloth.

Maintaining the equipment

The equipment is maintenance-free.

Servicing the equipment and installing spare parts

You may exchange the following component parts in case of wear or damage:

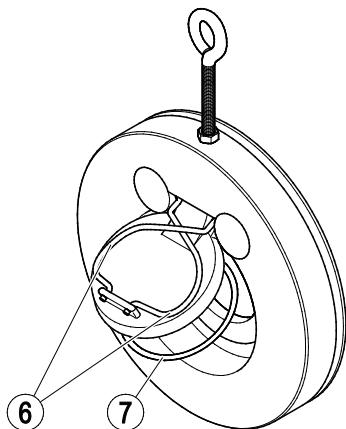

Spring (6)

DN	Stock code #	
	CB 24S	CB 26, CB 26A
50	038626	039294
65	038635	039295
80	038644	039296
100	038654	039297
125	038665	039298
150	038675	039299
200	038686	039300
250	038697	039301
300	038708	039302

Gasket (7)

DN	Stock code #			
	O ring EPDM	O ring FPM	O ring NBR ¹	O ring PTFE ²
50	039276	037556	038624	175843
65	031443	033910	038633	703368
80	031753	033911	038642	173844
100	031493	033912	038651	175839
125	031769	033913	038662	703369
150	031525	033914	038673	175841
200	031540	033915	038683	177839
250	039283	033916	038694	174450
300	031573	033917	038705	175131

1 Only CB 24S

2 CB 26 and CB 26A



For equipment type CB 14 there are no spare parts available.

Replacing spring and gasket

To mount and remove the spring and the gasket you need the following tools:

- ▶ Flat pliers or combination pliers
- ▶ Punch

To exchange the spring or the gasket you have to remove the equipment.

- ▶ Undo the nuts on the bolts.
- ▶ Pull the equipment out of the flanges.
- ▶ Remove the gaskets from the flanges.

Exchanging the gasket

- ▶ Undo the nuts on the bolts.
- ▶ Pull the equipment out of the flanges.
- ▶ Remove the gaskets from the flanges.
- ▶ To exchange the equipment gasket open the swing disk.
- ▶ Remove the gasket from the equipment.
- ▶ Insert a new gasket in the equipment.

Exchanging the springs

Attention!

If the operating temperature exceeds 300 °C malfunctions in equipment with springs may occur.

- ▶ If the operating temperature exceeds 300 °C remove the springs.

For this purpose proceed as follows:



WARNING

The springs are preloaded and their tension can cause injuries.

- ▶ Always wear safety goggles when replacing the springs.
- ▶ Mount or remove one spring after the other.
- ▶ Make sure that no uninvolved persons are standing in close vicinity of the equipment.

- ▶ Slowly press the first spring out of the bore and inwards.
- ▶ Slowly slacken the spring until the spring touches the body (2.).
- ▶ Pull the spring out of the hole in the hinge (3.).

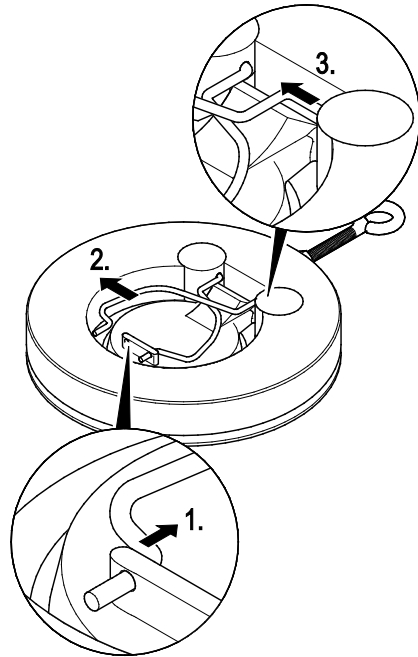

- ▶ Remove the second spring in the same way.



WARNING

The springs are preloaded and their tension can cause injuries.

- ▶ Always wear safety goggles when replacing the springs.
- ▶ Mount or remove one spring after the other.
- ▶ Make sure that no uninvolved persons are standing in close vicinity of the equipment.

Install the new springs as follows:

- Put the end of the spring into the hole in the hinge (1.)
- Carefully press the spring inwards (2.) and insert the end of the spring in the hole (3.).

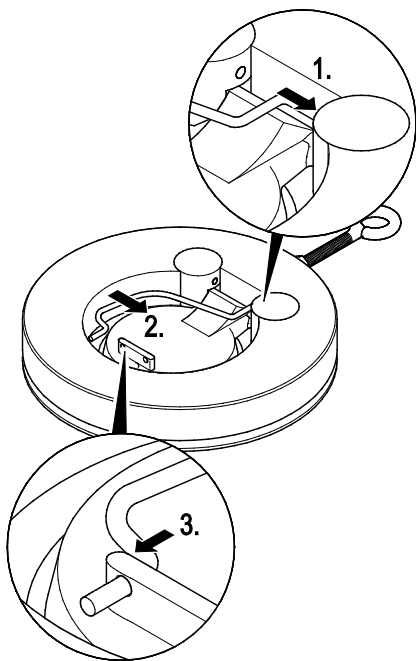

- Fit the second spring in the same way.
- Make sure that the swing disk can move smoothly.
- Mount the equipment in the pipe as described from page 9 onwards.

Troubleshooting

Problem	Cause	Remedy
Loud noise	The equipment is operating in the unstable range of the volume flow with the swing disk oscillating.	Raise the volume flow by increasing the pump capacity.
		Install the equipment at a different position.
	The distance between the equipment and the pump is too short.	Increase the distance of the equipment so that a stabilized flow is provided.
	The swing disk touches the pipe.	Align the equipment. Install the equipment at a position where the swing disk does not touch the pipe. Install an equipment that is suitable for the pipe.
Equipment leaks	The equipment is damaged.	Check the condition of the equipment. Replace the equipment if it is damaged.
	The spring is damaged or worn.	Check the condition of the springs. Replace any damaged or worn spring.
	A gasket is damaged.	Check the condition of the gaskets. Replace any defective gasket.

Putting the equipment out of operation

Removing harmful substances



DANGER

If the equipment is used in contaminated areas there is a risk of severe injuries or death caused by harmful substances in or on the equipment.

- Only qualified personnel are allowed to perform work on contaminated equipment.
- Always wear the protective clothing prescribed for contaminated areas when working on the equipment.
- Make sure that the equipment is completely decontaminated before carrying out any service work.
- Follow the pertinent instructions for handling the hazardous substances in question.

Qualified personnel must have extensive experience with and a working knowledge of:

- ▶ pertinent rules and regulations concerning handling hazardous substances
- ▶ special regulations for handling the hazardous substances encountered on site
- ▶ using the required personal protective equipment (PPE) and clothing

Attention!

Environmental damage may be caused by poisonous fluid residues.

- Before disposing of the equipment make sure that it is clean and free of fluid residues.
- For the disposal of all materials observe the pertinent legal regulations concerning waste disposal.

- Remove all residues from the equipment.
- For the disposal of all residues observe the pertinent legal regulations concerning waste disposal.

Removing the equipment



DANGER

Personnel working on pipes are exposed to safety risks and may suffer severe injuries, poisoning or even loss of life.

- Make sure that no hot or hazardous fluid is in the equipment or the pipes.
- Make sure that the pipes upstream and downstream of the equipment are depressurised.
- Make sure that the installation is switched off and protected against unauthorised or unintended activation.
- Make sure that the equipment and the pipes have cooled down to room temperatures.
- Wear protective clothing that is suitable for the fluid and, if necessary, wear protective gear.

For more information on suitable safety clothing and safety gear refer to the safety data sheet of the fluid in question.



CAUTION

Danger of bruising if the equipment falls down.

- When removing the equipment make sure the it is safely held in place and cannot fall down.

Suitable measures are for instance:

- ▶ Equipment that is not too heavy may be supported by a second person.
- ▶ For heavy equipment use suitable lifting equipment of sufficient strength.

- Detach the end connections of the equipment from the pipes.
- Put the equipment onto a suitable base.
- Store the equipment as described on page 8.

Re-using equipment after storage

Observe the following instructions if you want to remove the equipment and use it again somewhere else:

- ▶ Make sure that the equipment is free of any fluid residues.
- ▶ Make sure that all connections are in good condition and leak-free.
- ▶ Replace the gasket in the equipment with a new one of the same type.
- ▶ Replace the gaskets at the connections of the equipment with new ones of the same type.
- Use the equipment only for its intended purpose and the service conditions for which it was specified.

Disposing of the equipment

Attention!

Environmental damage may be caused by poisonous fluid residues.

- Before disposing of the equipment make sure that it is clean and free of fluid residues.
 - For the disposal of all materials observe the pertinent legal regulations concerning waste disposal.
-

The equipment is made from the following materials:

Materials CB 14

Component	EN number	Short designation
Body, pressure plate	1.0460	P250GH
Swing disk	(NBR)	(Perbunan)

Materials CB 24S

Component	EN number	Short designation
Body DN50–100	CC483K-GS	C-CuSn12-C
Body DN125–300	CC332G	CuAl10Ni3Fe2-C
Swing disk	CC332G	CuAl10Ni3Fe2-C
Springs	CW452K	CuSn6F90
Shaft and support pins	CW453K	CuSn8F38
Bushing ¹	CW453K	CuSn8F38

1 Only with DN 200–300

Materials CB 26

Component	EN number	Short designation
Body DN 50-200:	1.0460	P250GH
Body DN 250-300	1.0460	P250GH
Swing disk DN 50–150	1.4581	G-X5CrNiMoNb19-11-2
Swing disk DN 200–300	5.3103	EN-GJS-400-18-U-LT
Springs	1.4571	X6CrNiMoTi17-12-2
Shaft and support pins		
Bushing ¹		

1 Only with DN 200–300

Materials CB 26A

Component	EN number	Short designation
Body DN 50-250	1.4571	X6CrNiMoTi17-12-2
Body DN 300	1.4581	G-X5CrNiMoNb19-11-2
Swing disk	1.4581	G-X5CrNiMoNb19-11-2
Springs	1.4571	X6CrNiMoTi17-12-2
Shaft and support pins		
Bushing ¹		

1 Only with DN 200–300

Technical data

Dimensions and weights

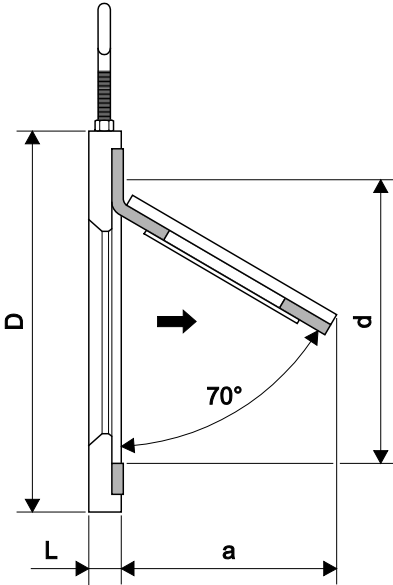

CB 14

DN	Dimensions [mm]				Weight [kg]
	L ¹	D	a	d ²	
50	14	98	45	47	0.7
65	14	118	60	64	1.0
80	14	132	70	75	1.4
100	14	154	90	98	1.5
125	16	184	115	124	2.5
150	16	209	145	148	3.3
200	18	264	185	196	5.5
250	35	319	220	242	11.2
300	43	375	270	288	14.0

1 Overall length according to EN558-1, series 95

2 Min. admissible flange bore (inside pipe diameter)

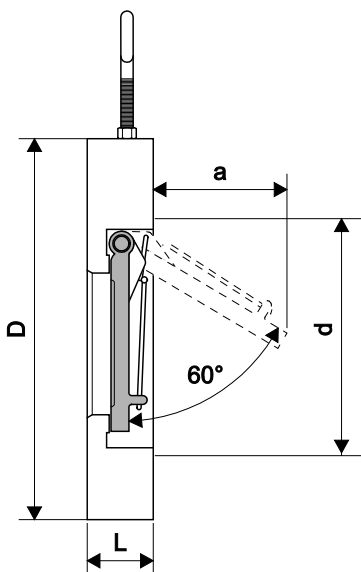

CB 24S

DN	Dimensions [mm]				Weight [kg]
	L ¹	D	a	d ²	
50	17	98	40	55	0.9
65	20	118	50	69	1.4
80	24	132	58	80	2.0
100	27	154	72	90	3.1
125	32	184	88	118	5.2
150	32	209	112	132	6.7
200	42	264	150	190	13.7
250	47	319	182	228	22.9
300	52	375	216	275	32.8

- 1 Overall length according to EN558-1, series 96
- 2 Min. admissible flange bore (inside pipe diameter)

CB 26 and CB 26A

DN	Dimensions [mm]				Weight [kg]
	L ¹	D	a	d ²	
50	17	98	40	55	0.9
65	20	118	50	69	1.4
80	24	132	58	80	2.0
100	27	154	72	90	3.1
125	32	184	88	118	5.3
150	32	209	112	132	6.9
200	42	264	150	190	14.1
250	47	319	182	228	23.6
300	52	375	216	275	33.8

- 1 Overall length according to EN558-1, series 96
- 2 Min. admissible flange bore (inside pipe diameter)

Pressure & temperature ratings

Pressure & temperature limits for CB 14, DN 50–300

T (temperature) [°C]	20	40	60	80
p (pressure) [bar]	16.0	10.0	6.0	4.0
Pressure rating	PN 16			
Min. temperature	-10 °C			

Pressure & temperature limits for CB 24S, DN 50–300

Based on EN1092-1 (2013)

T (temperature) [°C]	20	90 ¹	120 ¹	200 ¹	250 ¹
p (pressure) [bar]	16.0	16.0	16.0	16.0	15.6
Pressure rating	PN 16				
Min. temperature	-200 °C				

¹ If temperature exceeds 90 °C use equipment without springs.

Pressure & temperature limits for CB 26

Based on DIN EN12516-1 (2015)

T (temperature) [°C]	-10/20	100	200	300 ¹	350 ¹	400 ¹	450 ¹
DN 50–150							
p (pressure) [bar]	40.0	37.4	33.6	27.8	25.9	24.0	14.7
DN 200–300							
p (pressure) [bar]	40.0	37.4	33.6	27.8	25.9	–	–
Pressure rating	PN 40						
Min. temperature	-10 °C						

¹ If temperature exceeds 300 °C use equipment without springs.

Pressure & temperature limits for CB 26A, DN 50–300

Based on EN12516-1 (2014)

T (temperature) [°C]	20	100	150	200	250	300 ¹	350 ¹	400 ¹	450 ¹
p (pressure) [bar]	40.0	40.0	38.6	35.8	34.2	32.5	30.8	29.1	28.0
Pressure rating	PN 40								
Min. temperature	-10 °C								

1 If temperature exceeds 300 °C use equipment without springs.

If the operating temperatures exceed 300 °C intercrystalline corrosion may occur. Do not subject the equipment to operating temperatures higher than 300 °C unless intercrystalline corrosion can be ruled out.



For the max. flowrate as a function of the differential pressure see the capacity chart in the data sheet.

Manufacturer's declaration

For more information on the Conformity Assessment according to European rules refer to our Declaration of Conformity or our Declaration by Manufacturer.

To download the current Declaration of Conformity or Declaration by Manufacturer go to www.gestra.com/documents or contact:

GESTRA AG

Münchener Straße 77

28215 Bremen

Germany

Telefon +49 421 3503-0

Telefax +49 421 3503-393

E-Mail info@de.gestra.com

Web www.gestra.de

This declaration is no longer valid if modifications are made to the equipment without consultation with us.



Agencies all over the world: www.gestra.de

GESTRA AG

Münchener Straße 77

28215 Bremen

Germany

Telefon +49 421 3503-0

Telefax +49 421 3503-393

E-Mail info@de.gestra.com

Web www.gestra.de

810707-04/09-2016 kx_mm (808548-04) © GESTRA AG Bremen Printed in Germany