



Compact System

NRGS 11-1

NRGS 16-1



EN
English

Original Installation Instructions
810393-08

Contents

Page

Important Notes

Usage for the intended purpose	4
Safety note	4
Danger	4
Attention	4
LV (Low Voltage) Directive and EMC (Electromagnetic Compatibility)	4
ATEX (Atmosphère Explosible)	4

Explanatory Notes

Scope of supply	5
Description	5
Function	5
Design	5

Technical Data

NRGS 11 -1, NRGS 16-1	6, 7
Name plate / marking	8
Dimensions	9
Key	12

Design

NRGS 11 -1, NRGS 16-1	10
Key	12

Functional Elements

NRGS 11 -1, NRGS 16-1	11
Key	12

Installation

NRGS 11 -1, NRGS 16-1	13
NRGS 11 -1, NRGS 16-1	13
Table Functions	13
Attention	14
Note	14
Tools	14
Examples of installation	15
Key	16

Contents - continued -

Page

Electrical Connection

NRGS 11 -1, NRGS 16-1	17
Wiring diagram	17
Fill control.....	18
Discharge control.....	18
Attention.....	18
Tools.....	18

Basic Settings

Factory setting	19
Selecting the measuring range	19
Attention.....	19
Tools.....	19

Commissioning Procedure

Danger	20
Checking electrical connection	20
Checking correlation of switching functions	20
Applying mains voltage	20

Operation

NRGS 11 -1, NRGS 16-1	20
Note	20

Troubleshooting

Fault finding list for troubleshooting	21
--	----

Exchanging the electronic insert, removing the compact system

Danger	22
Replacing electronic insert.....	22
Removing and disposing of the compact system	22
Note	22

Disposal	23
-----------------------	-----------

Returning decontaminated equipment	23
---	-----------

EU Declaration of Conformity	23
---	-----------

Important Notes

Usage for the intended purpose

Use compact system for level monitoring NRGS 11-1 and NRGS 16-1 only for level indication in electrically conductive liquids.

Safety note

The equipment must only be installed and commissioned by qualified and competent staff. Retrofitting and maintenance work must only be performed by adequately trained persons who have a recognised level of competence.



Danger

When loosening the equipment steam or hot water might escape!
This presents the risk of severe scalding all over the body!
Do not remove the equipment unless the boiler pressure is verified to be 0 bar.
The terminal strip of the NRGS 11-1, NRGS 16-1 is live during operation.
This presents the danger of electric shock!
Cut off power supply before mounting or removing the housing cover!



Attention

The name plate specifies the technical features of the equipment. Do not commission or operate any item of equipment that does not bear its specific name plate.

LV (Low Voltage) Directive and EMC (Electromagnetic Compatibility)

The equipment meets the requirements of the Low Voltage Directive 2014/35/EU and the EMC Directive 2014/30/EU.

ATEX (Atmosphère Explosible)

According to the European Directive 2014/34/EU the equipment must not be used in potentially explosive areas.

Explanatory Notes

Scope of supply

NRGS 11-1

- 1 Compact system NRGS 11-1, PN 6
- 1 Joint ring D 33 x 39 DIN 7603-1.4301
- 1 Installation manual

NRGS 16-1

- 1 Compact system NRGS 16-1, PN 40
- 1 Joint ring D 33 x 39 DIN 7603-1.4301
- 1 Installation manual

Description

The compact system NRGS 11-1, NRGS 16-1 works according to the conductivity measurement system.

With the NRGS 11-1, NRGS 16-1 a maximum of 4 levels can be signalled in conductive liquids:

- 4 levels with one switchpoint each
- high-level alarm, low-level alarm, pump ON, pump OFF with one switchpoint each.

The compact system has a level controller integrated in the terminal box for the control of all functions. External switchgear is therefore **not** required.

Function

The conductivity of the liquid is used to signal the liquid level. Some liquids are conductive, which means that they allow an electric current to flow through them. For the safe functioning of this device a minimum conductivity of the liquid to be monitored is required

The conductivity measurement method can detect two conditions: electrode tip submerged or exposed, meaning switchpoint reached or not reached.

Before installation, the length of the electrode tips must be cut to the required switching levels, e. g. for high-level / low-level alarm, controlling of a valve or pump.

Design

NRGS 11-1, NRGS 16-1:

Screwed design 1" BSP, DIN ISO 228. **Fig. 2**

Technical Data

NRGS 11-1, NRGS 16-1

Type approval

NRGS 11-1: TÜV · WR · xx-388

NRGS 16-1: TÜV · WR · xx-388

Operating pressure

NRGS 11-1: 6 bar g at 159 °C

NRGS 16-1: 32 bar g at 238 °C

Mechanical connection

Screwed 1", DIN ISO 228

Materials

Body	3.2161 G AlSi8Cu3
Sheath	1.4301 X5 CrNi18-10
Measuring electrodes	1.4571 CrNiMoTi17-12-2
Electrode insulation	PTFE
Spacer disk	PTFE

Lengths available

500 mm

1000 mm

1500 mm

Mains voltage

230 V +/- 10 %, 50/60 Hz

115 V +/- 10 %, 50/60 Hz

24 V +/- 10 %, 50/60 Hz (optional)

Power consumption

5 VA

Fuse

Thermal fuse, $T_{\max} = 102\text{ °C}$

Sensitivity of response

Range 1: 10 $\mu\text{S/cm}$

Range 2: 0,5 $\mu\text{S/cm}$

Electrode voltage

10 V_{VS}

Output

Four volt-free relay contacts.

Max. contact rating with switching voltages of 24 V, 115 V and 230 V AC: resistive 4 A, inductive 0.75 A at $\cos \varphi$ 0.5.

Max. contact rating with a switching voltage of 24 V DC: 4 A.

Contact material: silver, hard-gold plated.

Technical Data - continued -

NRGS 11-1, NRGS 16-1 - continued -

Energizing/deenergizing delay

3 sec., factory set

Indicators and adjustors

4 red LEDs for signalling “electrode submerged”, “output relay energized”.
1 four-pole code switch for changing sensitivity.

Cable entry

Cable gland with integral cable clamp

M 16 (2) (PG 9)

M 20 (1) (PG 16)

Protection

IP 65 to DIN EN 60529

Max. admissible ambient temperature

70 °C

Weight

NRGS 11-1: approx. 1.8 kg

NRGS 16-1: approx. 1.8 kg

Name plate / marking





<p>Vor Öffnen des Deckels Gerät freischalten! Betriebsanleitung beachten</p> <p>Before removing cover isolate from power supplies See installation instructions</p> <p>Avant d'ouvrir le couvercle déconnecter complètement l'appareil Voir instructions de montage</p>		
	<p>NRGS 11 – 1 PN 6 <input type="checkbox"/></p>	
	<p>NRGS 16 – 1 PN 40 <input type="checkbox"/></p>	
	<p>NRGS 16 – 1s PN 40 <input type="checkbox"/></p>	
	<p>G 1 1.4571 <input type="checkbox"/></p>	
<p>DN 50 1.4571/1.0460 <input type="checkbox"/></p>		
	<p>6 bar (87psi) <input type="checkbox"/> 159°C (318°F)</p>	
	<p>32 bar (464psi) <input type="checkbox"/> 238°C (460°F)</p>	
	<p>Tamb 70°C (158°F) IP65</p>	
<p>24V <input type="checkbox"/> 115/230V <input type="checkbox"/></p>		
<p>50 / 60Hz</p>	<p>5VA</p>	<p>0,5 / 10µS/cm</p>
<p> 250V ~ T2,5A</p>		
<p>TÜV . WR . xx-388</p>		
		
<p>GESTRA AG Münchener Str. 77 Made in Germany</p>		
<p>Mat-Nr.:</p>		

Fig. 1

Dimensions

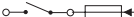
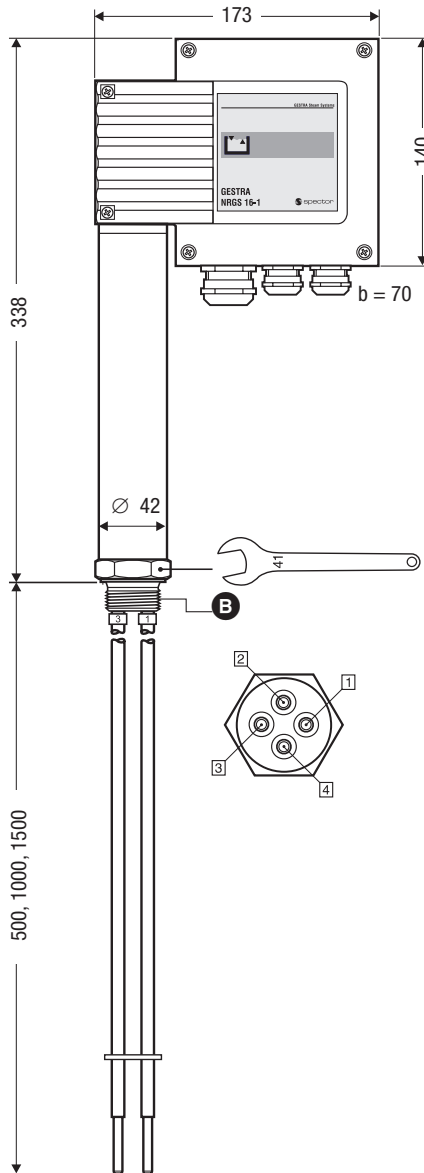
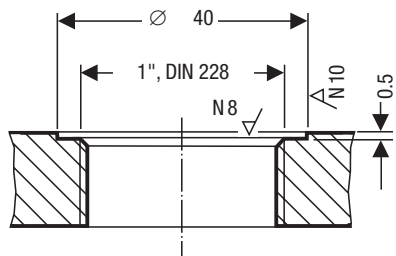
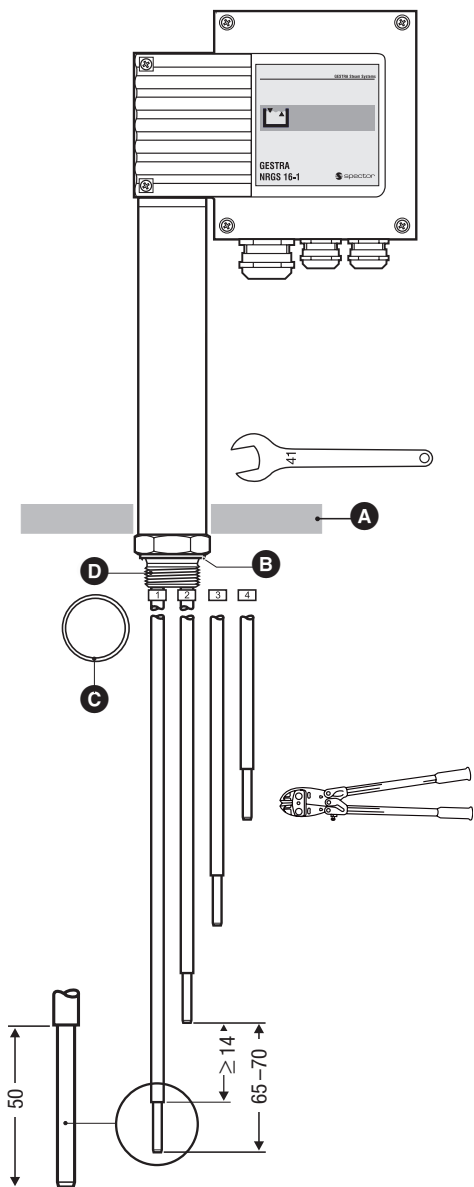

Fig. 2 NRG5 11-1, NRG5 16-1

Design

NRGS 11-1, NRGS 16-1



Functional Elements

NRGS 11-1, NRGS 16-1

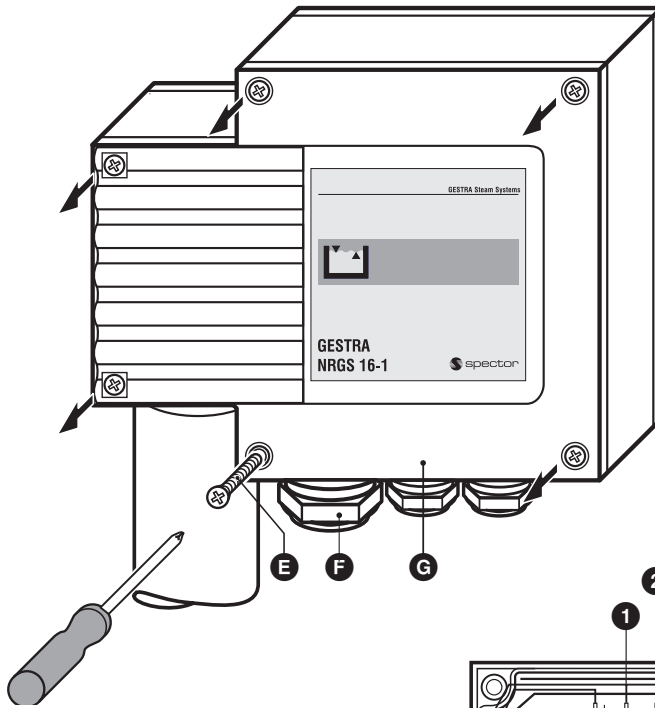

Fig. 5

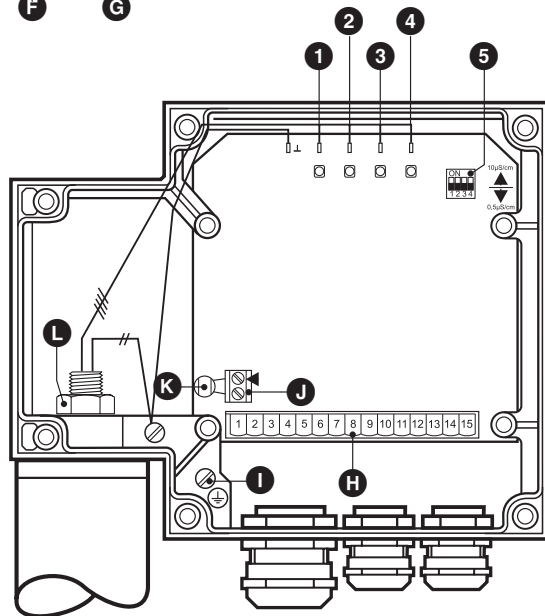

Fig. 6

Technical Data / Design / Functional Elements

Key

- A** Electrode thread 1", DIN 228
 - B** Seating surface
 - C** Joint ring D 33 x 39 DIN 7603 -1.4301
 - D** Flange DN 50, PN 40, DIN 2635
 - E** Housing screws M4
 - F** Cable entry M 16 (PG 9) / M 20 (PG 16)
 - G** Housing cover
 - H** Terminal strip
 - I** PE connection
 - J** Terminal strip for testing
 - K** Thermal fuse T_{max} 102 °C
 - L** Plug
-
- 1** LED "Low-level alarm"
 - 2** LED "Pump ON"
 - 3** LED "Pump OFF"
 - 4** LED "High-level alarm"
 - 5** Code switch for measuring range

Installation

NRGS 11-1, NRGS 16-1

1. Determine required measuring lengths of electrode tips and enter data in table "Functions". **Fig. 3**
2. Cut electrode tips **1**, **2**, **3** and **4** accordingly.
3. Deburr faces of electrode tips.
4. Strip off 50 mm of PTFE insulation from the ends of the electrode tips.

NRGS 11-1, NRGS 16-1

5. Check seating surfaces of threads or flange provided on vessel or boiler standpipe. **Fig. 4**
6. Place joint ring **Ⓒ** onto seating surface of the threaded standpipe or flange. **Fig. 4**
Use only the joint ring (of stainless steel 1.4301, D 33 x 39 DIN 7603) supplied with the electrode.
7. Apply a light smear of silicone grease (e. g. Molykote[®] 111) to electrode thread **Ⓐ**.
8. Screw level electrode into threads or flange provided on vessel and tighten with a 41 mm open-end spanner. The torque required when cold is 140 Nm.

Table Functions

Function	Function	Electrode tip	Length [mm]
e. g. first low-level alarm		1	
e. g. feed pump ON		2	
e. g. feed pump OFF		3	
e. g. high level alarm		4	

Please enter function and length.



Attention

- The seating surfaces of the standpipe or the flange provided on the vessel must be accurately machined, see **Fig. 4**
- Do not bend electrode tip when mounting.
- Do not lag electrode body above the hexagonal section.



Note

- For the approval of the boiler standpipe the relevant regulations must be considered.
- Refer to page 15 for four typical installation examples.

Tools

- Open-end spanner A. F. 41, DIN 894
- Bolt cutter
- Hacksaw
- Flat file, medium cut

Examples of installation

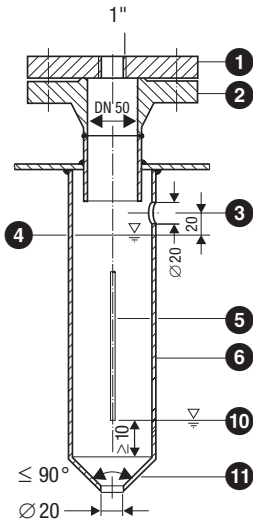

Fig. 7

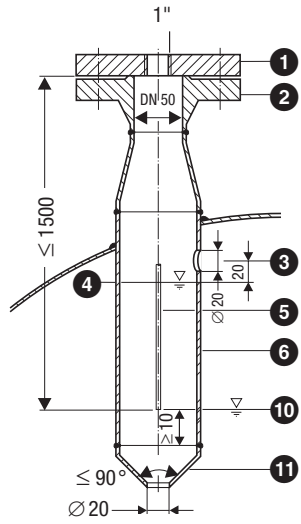

Fig. 8

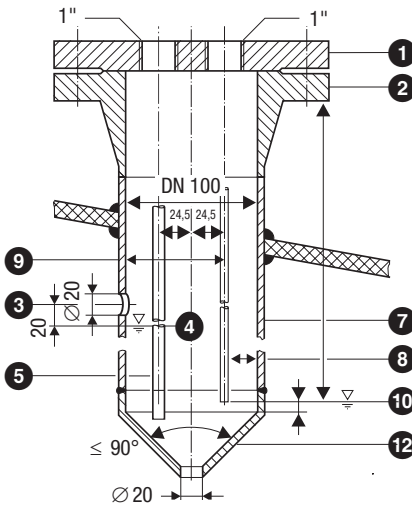

Fig. 9

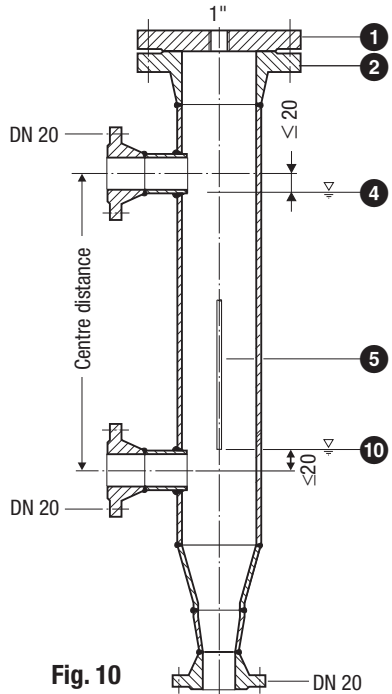

Fig. 10

Key

- 1 Flange PN 40, DN 50, DIN 2527
Flange PN 40, DN 100, DIN 2527
- 2 For the approval of the boiler standpipe with connecting flange the relevant regulations must be considered.
- 3 Vent hole
- 4 High water (HW)
- 5 Electrode rod $d = 5$ mm
- 6 Protection tube DN 80
- 7 Protection tube DN 100
- 8 Electrode distance ≥ 14 mm
- 9 Electrode distance ≥ 40 mm
- 10 Low water (LW)
- 11 Reducer DIN 2616, part 2 K-88.9 x 3.2-42.4 x 2.6 W
- 12 Reducer DIN 2616, part 2 K-114.3 x 3.6-48.3 x 2.9 W

Electrical Connection

NRGS 11-1, NRGS 16-1

Flexible multi-core control cable can be used for wiring, min. conductor size 1.5 mm².

1. Unscrew screws **E** and take off housing cover **G**. **Fig. 5**
2. Unscrew union nuts of cable entries **F**.

The terminal box can be turned through $\pm 180^\circ$.

3. Loosen nut **L** with 17 mm open-end spanner but do not remove! **Fig. 6**
4. Turn electrode terminal box into desired direction ($\pm 180^\circ$).
5. Tighten plug **L** slightly.
6. Remove terminal strips **H** from circuit board.
7. Connect terminal strip according to wiring diagram, establish PE connection **I**.
8. Attach terminal strip.
9. Mount housing cover **G**, fasten screws **E** and install cable entry **F**.

Wiring diagram

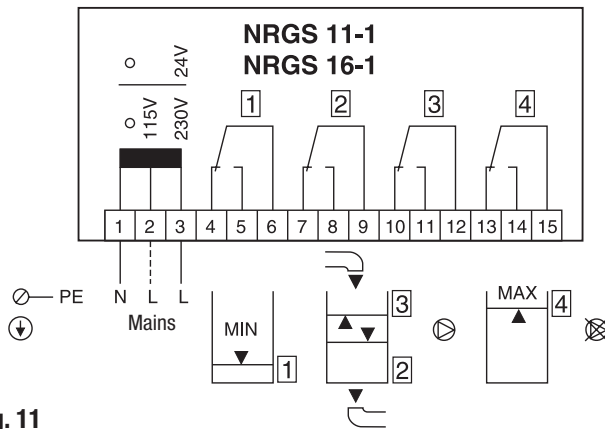

Fig. 11

Fill control

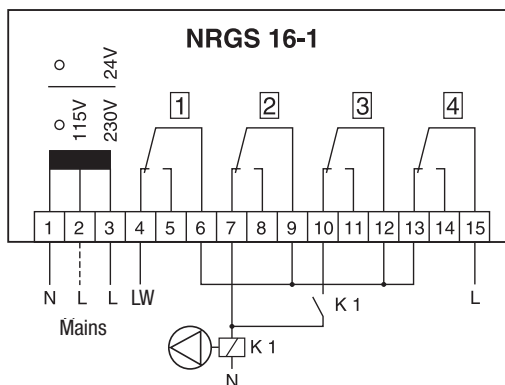

Fig. 12

Discharge control

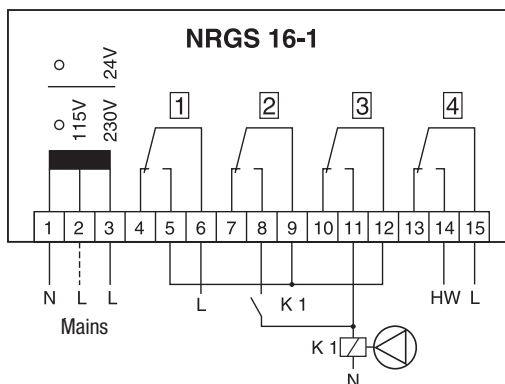

Fig. 13



Attention

- Provide supply cables with a slow-blow fuse 250 mA.
- The connection of the switchpoints **2** and **3** must be effected on site (pump contactor, auxiliary relay)!

Tools

- Screwdriver for cross head screws, size 1
- Screwdriver for slotted screws, size 2.5, completely insulated according to VDE 0680
- Open-end spanner A. F. 17, DIN 894

Basic Settings

Factory setting

The equipment features the following factory set default value:

- Measuring range $\geq 10 \mu\text{S/cm}$

Selecting the measuring range

The measuring range can be switch-selected between $\geq 0.5 \mu\text{S/cm}$ and $\geq 10 \mu\text{S/cm}$ by means of the code switch **5**:

1. Undo screws **E** of the electrode terminal box and remove housing cover. **Fig. 5**

Code switch 1–4 OFF  Measuring range $\geq 0.5 \mu\text{S/cm}$.

Code switch 1–4 ON  Measuring range $\geq 10 \mu\text{S/cm}$.

2. Replace cover **G** and fasten screws **E**.



Attention

- Do not damage the electronic components when setting the code switch!

Tools

- Screwdriver for cross head screws, size 1
- Screwdriver for slotted screws, size 2.5, completely insulated according to VDE 0680

Commissioning Procedure



Danger

The terminal strip of the NRGs 11-1, NRGs 16-1 is live during operation.
This presents the danger of electric shock!
Cut off power supply before mounting or removing the housing cover!

Checking electrical connection

1. Check whether the system has been wired according to the wiring diagram. **Fig. 11**
2. Check whether the mains supply is in accordance with the wiring of the equipment.

Checking assignation of switching functions

1. Check whether the designated switchpoints (i. e. switching functions) have been correctly allocated to the individual electrode tips. See table **“Functions”** page 13.

Applying mains voltage

1. Apply mains voltage. Check that all functions of the respective switchpoints work correctly.
LEDs **1**, **2**, **3**, **4** are provided for visual check of switchpoints. **Fig. 6**

To check the correct functioning of the LEDs **1**, **2**, **3**, **4** remove the housing cover **6**. See section **“Electrical Connection”**.

Operation

NRGS 11-1, NRGs 16-1

For operation in (pressurized) hot-water or steam boilers to EN 12952, EN 12953 or according to national directives.



Note

- To analyse and eliminate malfunctions refer to section **“Fault finding list for trouble-shooting”** on page 21.

Troubleshooting

Fault finding list for troubleshooting

Switchpoint “High-level alarm” exceeded – no function

Fault: Mains voltage is not applied.

Remedy: Switch on power supply and wire equipment in accordance with the wiring diagram.

Fault: The thermal fuse has been triggered.

Remedy: In case of a defective thermal fuse the mains voltage has not been applied to terminal **U**.
Discard and replace defective thermal fuse.
Stock code # 052433.
The ambient temperature must not exceed 70 °C.

Remedy: The electrical conductivity is too low.

Remedy: Set code switch **5** to $\geq 0.5 \mu\text{S/cm}$.

Fault: The electrode body does not have earth connection to the boiler.

Remedy: Clean seating surfaces and insert metal joint ring
(of stainless steel 1.4301) D 33 x 39 to DIN 7603.
Do **not** insulate compact system with hemp or PTFE tape!

Fault: Electronic circuit board defective.

Remedy: Replace circuit board NRV 1-43. Stock code # 321321 (mains voltage 115/230 V AC) or
312338 (mains voltage 24 V AC).

Level below switchpoint “Low level” – no function

Fault: The electrode tips have earth contact.

Remedy: Check and, if necessary, change position of installation.

Fault: The vent hole in the protection tube does not exist, is obstructed or flooded.

Remedy: Check protection tube and, if necessary, provide vent hole.

Fault: The isolating valves of the external measuring pot (optional extra) are closed.

Remedy: Open isolating valves.

Switchpoint has been reached – incorrect function

Fault: The switching function has not been assigned correctly.

The electrode tips have been cut to the wrong length.

Remedy: Identify electrode supply wires and reconnect the circuit board accordingly.

If faults occur that are not listed above or cannot be corrected, please contact our service centre or authorized agency in your country.

Exchanging the electronic insert, removing the compact system



Danger

When loosening the compact system steam or hot water might escape!

This presents the risk of severe scalding all over the body!

It is therefore essential not to dismantle the compact system unless the boiler pressure is verified to be 0 bar.

The compact system becomes hot during operation. Touching the hot equipment presents the risk of severe burns to hands and arms. All installation, removal and maintenance work must only be performed when the system is cold.

The terminal strips of the compact system are live during operation.

This presents the danger of electric shock!

Always **cut off power supply** to the equipment before mounting, removing or connecting the terminal strips!

Exchanging the electronic insert

Before exchanging the electronic insert take the compact system out of service and cut off its voltage supply.

1. Unscrew the housing screws **E** and remove the cover **G**. (Fig. 5, 6)
2. Pull the electrode wires off the terminal lugs on the electronic insert. Unplug the terminal strip **H**.
3. Undo the PE connection **I**.
4. Unscrew the fixing screws of the electronic insert and take out the electronic insert. The electronic insert is available as spare part type NRV 1-43.
5. Install the new electronic insert in reverse order.

Removing and disposing of the compact system

Before removing the compact system take it out of service and cut off its voltage supply.

1. Unscrew the housing screws **E** and remove the cover **G**. (Fig. 5, 6)
2. Detach the connecting wires from the terminal strips **H** and pull the wires out of the cable glands.
3. Undo the PE connection **I**.
4. Before removing the compact system make sure that it is neither hot nor under pressure.

For the disposal of the equipment observe the pertinent legal regulations concerning waste disposal.



Note

When ordering spare parts or replacement equipment please state the material number indicated on the name plate.

Disposal

Dispose of the level transmitter in accordance with statutory waste disposal regulations.

Returning decontaminated equipment

If products have come into contact with media that are hazardous to health, they must be drained and decontaminated before being returned to GESTRA AG.

The term media can refer to solid, liquid or gaseous substances or mixtures, as well as radiation.

GESTRA AG can accept returned products only if accompanied by a completed and signed return note and also a completed and signed declaration of decontamination.



The return confirmation and declaration of decontamination must be attached to the outside of the return package, as processing will otherwise be impossible and the products will be returned to the sender at their expense.

Please proceed as follows:

1. Let GESTRA AG know about the return beforehand by e-mail or phone.
2. Wait until you have received the return confirmation from GESTRA.
3. Fill out the return confirmation (and declaration of decontamination) and send it with the products to GESTRA AG.

EU Declaration of Conformity

We hereby declare that the NRGs 11-1, NRGs 16-1 compact systems conforms to the following European Directives:

- | | |
|------------------------|-----------------------|
| ■ Directive 2014/35/EU | Low Voltage Directive |
| ■ Directive 2014/30/EU | EMC Directive |
| ■ Directive 2011/65/EU | RoHS Directive |

Please see our Declaration of Conformity for details on the conformity of our equipment with European directives.

The current Declaration of Conformity can be found on the internet at www.gestra.com or requested from us.



Agencies all over the world: www.gestra.com

GESTRA AG

Münchener Straße 77

28215 Bremen

Germany

Telefon +49 421 3503-0

Telefax +49 421 3503-393

E-mail info@de.gestra.com

Web www.gestra.com