

Steam Trap

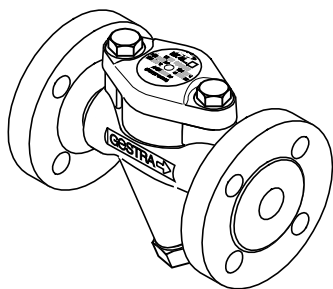

MK 45-1

MK 45-2

MK 45 A-1

MK 45 A-2



Contents

Foreword	3
Availability.....	3
Formatting features in the document	3
Safety	3
Use for the intended purpose	3
Basic safety notes	4
Typographic features of warning notes.....	5
Formatting features for warnings of property damage	5
Description	5
Scope of supply and equipment specification	5
Application of European Directives	9
Task and function	9
Storing and transporting the equipment	10
Storing the equipment	10
Transporting the equipment	10
Mounting and connecting the equipment	10
Preparing installation	10
Connecting the equipment	11
Operation	12
After operation	12
Removing external dirt deposits	12
Maintaining the equipment.....	13
Servicing the equipment and installing spare parts	13
Troubleshooting	18
Putting the equipment out of operation	21
Removing harmful substances.....	21
Removing the equipment	21
Re-using equipment after storage.....	22
Disposing of the equipment.....	22
Technical data	23
Dimensions and weights	23
Pressure & temperature ratings	24
Manufacturer's declaration	26

Foreword

This installation & operating manual will help you use the following types of equipment safely and efficiently for their intended purpose.

- ▶ MK 45-1
- ▶ MK 45-2
- ▶ MK 45 A-1
- ▶ MK 45 A-2

These steam traps will be called equipment in this document.

This installation & operating manual is intended for anyone commissioning, using, operating, servicing, cleaning or disposing of this equipment and, in particular, for professional after-sales service technicians, qualified personnel and authorised and trained staff.

All of these persons must read and understand the content of this installation & operating manual.

Following the instructions given in this installation & operating manual helps avoiding danger and increases the reliability and service life of the equipment. Please note that in addition to the instructions given in this installation & operating manual you must also observe all locally applicable rules and regulations concerning the prevention of accidents as well as approved safety guidelines for good professional practice.

Availability

Keep this installation & operating manual together with the plant documentation for future reference. Make sure that this installation & operating manual is available to the operator.

The installation & operating manual is part of the equipment. Please hand over this installation & operating manual when selling the equipment or passing it on.

Formatting features in the document

Certain text elements of this installation & operating manual feature a specific typographic design. You can easily distinguish the following text elements:

Standard text

Cross-reference

- ▶ Listing
 - ▶ Sub-items in listings
- Steps for action.



Here you will find additional useful information and tips serving to assist you in using the equipment to its fullest potential.

Safety

Use for the intended purpose

The following thermostatic/thermodynamic steam traps are installed in steam lines:

- ▶ MK 45-1
- ▶ MK 45-2
- ▶ MK 45 A-1
- ▶ MK 45 A-2

This equipment is designed for discharging condensed water or air-venting pipes.

The equipment must only be used within the allowable pressure and temperature limits and only if the chemical and corrosive influences on the equipment are taken into account.

Do not expose the control membrane of the membrane regulator capsule to superheat conditions above 5 °C.

Correct use includes compliance with the instructions given in this installation & operating manual, in particular obedience to all safety instructions.

Any other use of the equipment is considered to be improper.

Note that the equipment is also used incorrectly if the materials of the equipment are not suitable for the fluid.

Basic safety notes

Risk of severe injuries

- ▶ The equipment is under pressure during operation and may be hot. Before carrying out any work on the equipment make sure that the following requirements are met:
 - ▶ The pipes must be depressurized (0 bar).
 - ▶ The fluid must be completely removed from the pipes and the equipment.
 - ▶ During work on the equipment the installation must be switched off and protected against unauthorised or unintended activation.
 - ▶ The pipes and the equipment must have cooled down to room temperature (approx. 20 °C).
- ▶ If the equipment is used in contaminated areas there is a risk of severe injuries or death caused by harmful substances in or on the equipment. Before working on the equipment make sure that it is completely decontaminated. Always wear the protective clothing prescribed for contaminated areas when working on the equipment.
- ▶ The equipment must only be used with fluids that do not attack the material and the gaskets and sealings of the equipment. Otherwise leaks may occur and hot or toxic fluid could escape.
- ▶ The equipment and its component parts must only be mounted or removed by qualified personnel. A qualified person must be acquainted with and experienced in the following:
 - ▶ Making pipe connections.
 - ▶ Selecting suitable lifting gear and understanding the rules for its safe use.
 - ▶ Working with dangerous (contaminated, hot or pressurized) fluids.

Risk of minor injuries

- ▶ Sharp edges on internals present the danger of cuts to hands. Always wear industrial gloves when servicing the equipment.
- ▶ If the support of the equipment during installation is insufficient the equipment might fall down, thereby causing bruises or injuries. Make sure the equipment is safely held in place during installation and cannot fall down. Wear protective safety footwear.

Information on property damage or malfunctions

- ▶ Malfunctions will occur if the equipment is installed in a wrong position or with the flow arrow pointing in the opposite direction of the fluid flow. This may result in damage to the equipment or the installation. Make sure that the flow arrow on the equipment body matches the indicated direction of the fluid flow in the pipe.
- ▶ If the material is unsuitable for the fluid, increased wear may occur and fluid may escape. Make sure that the material is suitable for the fluid used in your installation.

Typographic features of warning notes



DANGER

Notes with the heading DANGER warn against imminent dangerous situations that can lead to death or serious injuries.



WARNING

Notes with the heading WARNING warn against possibly dangerous situations that could lead to death or serious injuries.



CAUTION

Notes with the heading CAUTION warn against dangerous situations that could lead to minor or moderate injuries.

Formatting features for warnings of property damage

Attention!

This information warns of a situation leading to property damage.

Description

Scope of supply and equipment specification

Scope of supply

Our equipment is delivered packed and ready for assembly.

Equipment specification

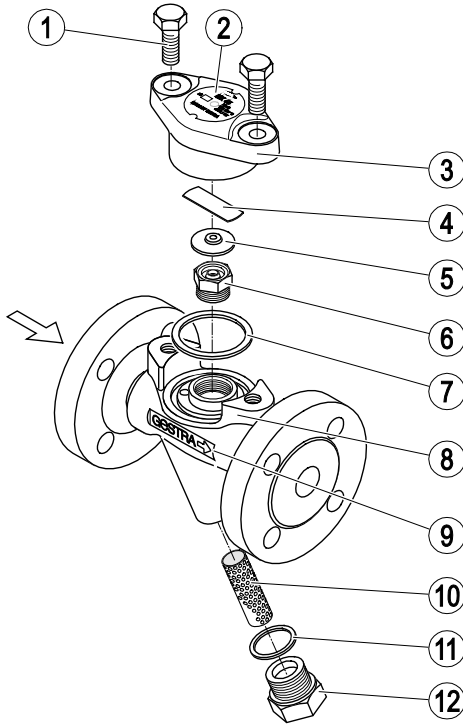

No.	Designation
1	Screw
2	Name plate
3	Cover
4	Spring
5	Membrane regulator capsule
6	Nozzle insert

No.	Designation
7	Cover gasket
8	Body
9	Flow arrow
10	Strainer
11	Gasket
12	Sealing plug

The equipment is available with two different types of membrane regulator capsules with the associated nozzle insert.

MK 45-1 and MK 45 A-1

▶ Tandem-seated membrane regulator capsule for nozzle insert, suitable for the following condensate flowrates:

- ▶ hot: approx. 10 – 600 kg/h
- ▶ cold 20 °C: approx. 0 – 1000 kg/h

MK 45-2 and MK 45 A-2

▶ Single-seated membrane regulator capsule for nozzle insert, suitable for the following condensate flowrates:

- ▶ hot: approx. 15 – 1100 kg/h
- ▶ cold 20 °C: approx. 0 – 2800 kg/h



Please refer to the capacity charts in the pertinent data sheet for more information on condensate flowrates.

Tandem-seated membrane regulator capsule for nozzle insert

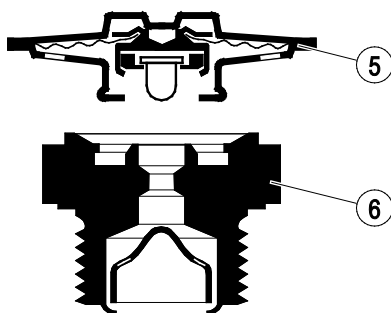

No.	Designation
5	Tandem-seated membrane regulator capsule for nozzle insert
6	Nozzle insert (with tandem seat)



The nozzle insert features an integral non-return valve to prevent back flow.

The membrane regulator capsules are available for three different opening temperatures.

Type	Undercooling
5N1	ΔT approx. 10 K (standard)
5U1	ΔT approx. 30 K
5H1	ΔT approx. 5 K

Single-seated membrane regulator capsule for nozzle insert

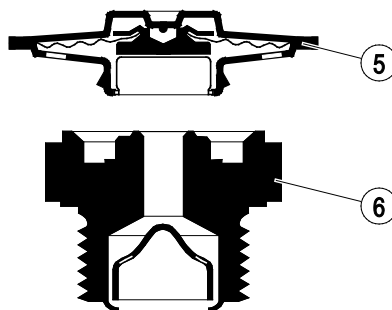

No.	Designation
5	Single-seated membrane regulator capsule for nozzle insert
6	Nozzle insert (with tandem seat)



The nozzle insert features an integral non-return valve to prevent back flow.

The membrane regulator capsules are available for three different opening temperatures.

Type	Undercooling
5N2	ΔT approx. 10 K (standard)
5U2	ΔT approx. 30 K
5H2	ΔT approx. 5 K

Markings on the membrane regulator capsule

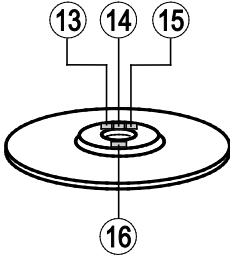

No.	Description
13	Code number for type
14	Code letter for opening temperature
15	Code number for capacity
16	Manufacturing code

Optional extras

The following add-on equipment is available:

- ▶ Blow-off valve
- ▶ Ultrasonic test device VAPOPHONE®
- ▶ Continuous condensate monitoring equipment

End connections

The equipment is available with the following end connections:

- ▶ Butt-weld ends
- ▶ Socket-weld ends
- ▶ Flanges
- ▶ Screwed sockets

Name plate

The following items are indicated on the name plate:

- ▶ Manufacturer
- ▶ Type designation
- ▶ Nominal size
- ▶ Pressure rating
- ▶ Max. service pressure
- ▶ Max. service temperature
- ▶ Max. admissible differential pressure
- ▶ Max. service temperature at the corresponding service pressure
- ▶ Code letter for opening temperature of membrane regulator capsule

The following items are indicated on the equipment body:

- ▶ Material
- ▶ Direction of flow
- ▶ Date of manufacturing

Application of European Directives

Pressure Equipment Directive

The equipment conforms to this directive (see "Manufacturer's Declaration" section) and can be used for the following media:

- ▶ Fluids of group 2

ATEX Directive

The equipment does not have its own potential ignition source and is not subject to this directive (see "Manufacturer's Declaration" section).

When installed, static electricity may arise between the equipment and the connected system. When used in potentially explosive atmospheres, the plant manufacturer or plant operator is responsible for discharging or preventing possible static charge.

If it is possible for medium to escape, e.g. through actuating mechanisms or leaks in threaded joints, the plant manufacturer or plant operator must take this into consideration when dividing the area into zones.

Task and function

This equipment is designed for discharging condensed water or air-venting steam lines.

Condensate discharge is controlled by the membrane regulator capsule and the associated nozzle insert. The membrane regulator capsule is located on top of the nozzle insert.

Function of the single-seated capsule for nozzle insert

The membrane regulator capsule contains a liquid filling the evaporation temperature of which is a few degrees below the saturation temperature of water (condensate). From cold to just below steam temperature the fluid filling in the capsule stays liquid and condensate is discharged.

As condensate temperature approaches steam temperature, the capsule filling begins to evaporate and the increased pressure forces the flexible control membrane inside the capsule onto the single seat, thereby closing the nozzle insert. The control characteristic of the membrane regulator capsule closely follows the saturated steam curve.

Function of the tandem-seated capsule for nozzle insert

The tandem seat capsule basically works like the single seat capsule but features a double seat that ensures tight shut-off and a long trap life. First the self-centering valve cone gives steam tight shut-off. Then, as the condensate temperatures rises, the second seat also seals off the nozzle insert.

Storing and transporting the equipment

Attention!

Equipment can be damaged if stored or transported improperly.

- Close all openings with the sealing plugs or covers supplied with the equipment or use similar sealing covers.
- Protect the equipment against moisture and corrosive atmospheres.
- Please contact the manufacturer if the specified transport and/or storage requirements cannot be met.

Storing the equipment

- Please observe the following items when storing the equipment:
 - ▶ Do not store the equipment for more than 12 months.
 - ▶ Use the supplied sealing plugs or other suitable seal caps in order to seal off all openings of the equipment.
 - ▶ Protect the sealing surfaces and contact areas against mechanical damage.
 - ▶ Protect the equipment and all components against hard shocks and impacts.
 - ▶ Store the equipment only in closed rooms that meet the following environmental conditions:
 - ▶ Air humidity below 50 %, not condensing
 - ▶ Indoor air: clean, salt-free and non-corrosive
 - ▶ Temperature 5–40 °C.
- Make sure that all these requirements are always met when storing the equipment.
- Please contact the manufacturer if you cannot comply with the recommended storage conditions.

Transporting the equipment

- Meet the requirements for storage also when transporting the equipment.
- Prior to transport seal off connections with sealing plugs.



If you do not have the sealing plugs supplied with the equipment use appropriate seal caps to seal off the connections.

- For short distances (only a few metres) you can transport the equipment unpacked.
- When transporting the equipment over larger distances use the original packaging.
- If you do not have the original packaging use a box that protects the equipment adequately against corrosion and physical damage.



For a short period of time the equipment may be transported even if the temperature is below 0 °C, provided that the equipment is completely empty and dry.

Mounting and connecting the equipment

Preparing installation

- Take the equipment out of the transport packaging.
- Check the equipment for transport damage.
- Contact the manufacturer if you detect any kind of shipping damage.

When supplied by the factory, the connections may be sealed off with sealing plugs.

- Remove sealing plugs before mounting the equipment.
- Keep the sealing plugs and the packing for further use.



DANGER

Personnel working on pipes are exposed to safety risks and may suffer severe injuries, poisoning or even loss of life.

- Make sure that no hot or hazardous fluid is in the equipment or the pipes.
- Make sure that the pipes upstream and downstream of the equipment are depressurised.
- Make sure that the installation is switched off and protected against unauthorised or unintended activation.
- Make sure that the equipment and the pipes have cooled down to room temperatures.
- Wear protective clothing that is suitable for the fluid and, if necessary, wear protective gear.

For more information on suitable protective clothing and safety gear refer to the safety data sheet of the fluid in question.

- Drain pipes until they are empty.
- Switch the installation off and protect it against unauthorised or unintended re-activation.

Connecting the equipment



DANGER

Incorrectly connected equipment can cause fatal accidents or severe injuries.

- Make sure that only qualified skilled personnel connect the equipment to pipes.
- Make sure that the flow arrow on the equipment body matches the direction of flow in the pipe.

Specialist personnel must be highly qualified and fully experienced in making pipe connections for the respective type of end connection.

Attention!

Equipment will be damaged if the end connections are undersized.

- Make sure that the connections are strong and rigid enough to support the weight of the equipment and to withstand the forces that occur during operation.

To allow easy access for routine servicing and exchanging components observe the indicated withdrawal distances and allow for clearances to adjacent installation parts.

For more information see page 23.

- Make sure that the pipe system of the plant is clean.
- Preferred installation of the equipment with the strainer insert hanging downwards.



Other installation orientations of the strainer are possible in exceptional cases.

Attention!

Any installation position where the strainer insert does not point downwards may impair the correct function of the equipment.

- Please consult the factory with installation details if the equipment cannot be installed in your installation with the strainer hanging downwards.

-
- Make sure that the equipment is free from foreign matter.

Attention!

Welding might damage the membrane regulator capsule.

- Remove the membrane regulator capsule before welding.

For more information see page 16.

- Mount the equipment in the desired installation position.
- Make sure that the equipment is safely mounted and that all connections are made correctly.

Attention!

Malfunctions may occur if the equipment or condensate line is insulated.

- Make sure that the heat generated by the equipment or the condensate line is dissipated.

Operation

Do not work on the equipment while it is operating.

After operation



DANGER

If the equipment is used in contaminated areas there is a risk of severe injuries or death caused by harmful substances in or on the equipment.

- Only qualified personnel are allowed to perform work on contaminated equipment.
- Always wear the protective clothing prescribed for contaminated areas when working on the equipment.
- Make sure that the equipment is completely decontaminated before carrying out any service work.
- Follow the pertinent instructions for handling the hazardous substances in question.

Attention!

Frost damage may occur when the installation is shut down.

- Drain the equipment if ambient temperatures below 0 °C (frost) are to be expected.

Removing external dirt deposits

- To remove dirt deposits rinse the equipment with fresh water and wipe it with a clean, lint-free cloth.
- To remove any persistent residues use a cleaning agent that is suitable for the material and carefully wipe the equipment with a clean, lint-free cloth.

Maintaining the equipment

You can check the equipment for correct operation using the GESTRA ultrasonic measuring unit VAPOPHONE®.

- For more details refer to the installation & operating manual of the ultrasonic measuring unit.

Continuous steam trap monitoring is recommended for critical applications.

- For more details refer to the installation & operating manual of the continuous steam trap monitoring unit.

Servicing the equipment and installing spare parts

You may exchange the following component parts in case of wear or damage:

- ▶ Membrane regulator capsule with nozzle insert, complete
- ▶ Membrane regulator capsule
- ▶ Strainer
- ▶ Cover gasket
- ▶ Gasket

Spare parts for version with tandem seat

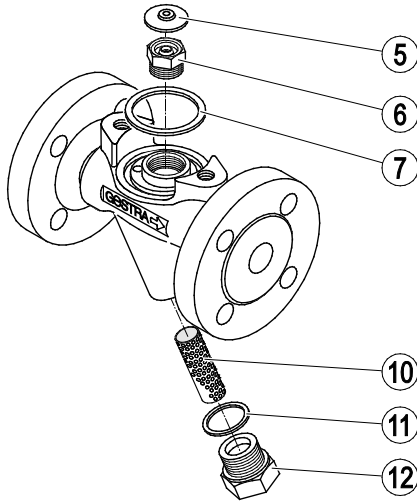

No.	Designation	Stock code #	
		MK 45-1	MK 45A-1
5, 6, 7	Tandem-seated membrane regulator capsule 5N1 and nozzle insert, complete	375 109	375 109
	Tandem-seated membrane regulator capsule 5U1 and nozzle insert, complete	375 111	375 111
	Tandem-seated membrane regulator capsule 5H1 and nozzle insert, complete	378 521	378 521
10, 11, 12	Strainer with sealing plug and gasket	375 113	375 382
5	Tandem-seated membrane regulator capsule 5N1 for nozzle insert *	376 165	376 165
	Tandem-seated membrane regulator capsule 5U1 for nozzle insert *	376 166	376 166
	Tandem-seated membrane regulator capsule 5H1 for nozzle insert *	376 173	376 173
7	Cover gasket **	375 159	375 159
11	Gasket **	375 162	375 162

*: Packaged 10 pcs. per box. Contact your local dealer for smaller quantities.

** Packaged 50 pcs. per box. Contact your local dealer for smaller quantities.

Spare parts for version with single seat

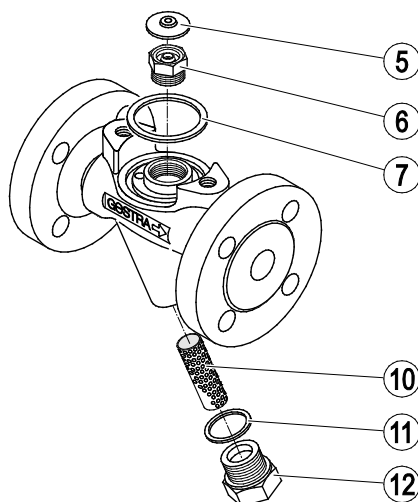

No.	Designation	Stock code #	
		MK 45-2	MK 45A-2
5, 6, 7	Single-seated membrane regulator capsule 5N2 and nozzle insert, complete	375 110	375 110
	Single-seated membrane regulator capsule 5U2 and nozzle insert, complete	375 112	375 112
	Single-seated membrane regulator capsule 5H2 and nozzle insert, complete	377 589	377 589
10, 11, 12	Strainer with sealing plug and gasket	375 113	375 382
5	Single-seated membrane regulator capsule 5N2 for nozzle insert *	376 167	376 167
	Single-seated membrane regulator capsule 5U2 for nozzle insert *	376 168	376 168
	Single-seat membrane regulator capsule 5H2 for nozzle insert *	376 174	376 174
7	Cover gasket **	375 159	375 159
11	Gasket **	375 162	375 162

*: Packaged 10 pcs. per box. Contact your local dealer for smaller quantities.

** Packaged 50 pcs. per box. Contact your local dealer for smaller quantities.

Removing the membrane regulator capsule and nozzle insert

To clean and, if necessary, discard and replace the membrane regulator capsule and the nozzle insert proceed as follows:

- Use a 16 mm open-end spanner (US: wrench) to unscrew the two screws from the body.
- Lift the cover off the body.
- Remove the cover gasket.
- Take the membrane regulator capsule off the nozzle insert.
- Use a 22 mm open-end spanner (US: wrench) to unscrew the nozzle insert from the body.

Cleaning the membrane regulator capsule and nozzle insert

- Clean the membrane regulator capsule and the nozzle insert with fresh water and a lint-free cloth.
- Clean gasket seating surfaces.

Checking the component parts for damage

- Check the removed parts for visible signs of wear or damage.
- Discard and replace any damaged part.

Checking the membrane regulator capsule

- Use a depth gauge to check the dimension x of the membrane regulator capsule as shown in the following drawing.

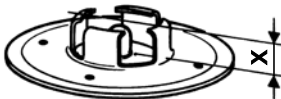

The membrane regulator capsule is intact if your readings match the values indicated in the following table.

Type	Intact	Defective
Tandem-seated membrane regulator capsule for nozzle insert 5N1, 5U1, 5H1	$x > 2.9 \text{ mm}$	$x < 2.9 \text{ mm}$ $x = 2.9 \text{ mm}$
Single-seated membrane regulator capsule for nozzle insert 5N2, 5U2, 5H2	$x > 4.0 \text{ mm}$	$x < 4.0 \text{ mm}$ $x = 4.0 \text{ mm}$

- Discard and replace defective membrane regulator capsule with a new one.

Mounting the membrane regulator capsule and nozzle insert

To install the membrane regulator capsule and the nozzle insert proceed as follows:

- Apply heat-resistant lubricant to the following surfaces:
 - all threads
 - the seating surface of the nozzle insert
 - the seating surface of the cover
- Use a 22 mm open-end spanner (US: wrench) to screw the nozzle insert into the body and tighten with a torque of 90 Nm.
- Press the membrane regulator capsule onto the nozzle insert.

The membrane regulator capsule snaps into place.

- If the cover gasket is damaged replace it with a new one.
- Put the cover gasket into the body.
- Put the cover onto the body.
- Tighten the screws alternately and in several steps with a torque of 25 Nm.

Removing and cleaning the strainer

To remove and, if required, clean or replace the strainer proceed as follows:

- Use a 30 mm open-end spanner (US: wrench) to unscrew the sealing plug from the body.
- Remove the gasket.
- Take out the strainer.
- Clean the sealing plug, the gasket and the strainer with fresh water and a clean lint-free cloth.
- Clean gasket seating surfaces.

Checking the component parts for damage

- Check the removed parts for visible signs of wear or damage.
- Discard and replace any damaged part.

Mounting the strainer

To remove the strainer proceed as follows:

- Apply heat-resistant lubricant to the thread of the sealing plug.
- If the gasket is damaged replace it with a new one.
- Put the gasket onto the sealing plug.
- Insert the strainer into the sealing plug.
- Use a 30 mm open-end spanner (US: wrench) to screw the sealing plug into the body and tighten with a torque of 75 Nm.

Troubleshooting

Fault	Cause	Remedy
The steam trap is cold or only hand-hot.	The shut-off valves for condensate inlet or outlet are closed.	Open the shut-off valves.
	The condensate inlet or outlet is dirt clogged.	Clean the pipes. Clean the equipment.
The steam trap is blowing off live steam.	The membrane regulator capsule and the nozzle insert are dirty. There are dirt deposits in the equipment.	Clean the membrane regulator capsule and the nozzle insert. Clean the strainer and the equipment. Replace the membrane regulator capsule and the nozzle insert.
	The membrane regulator capsule and the nozzle insert are worn down. The seat is leaking.	Replace the membrane regulator capsule and the nozzle insert.
	The bypass is open.	Close the bypass.

Fault	Cause	Remedy
<p>Insufficient condensate discharge.</p> <p>Insufficient thermal output for the user.</p>	The shut-off valves for condensate inlet or outlet are closed.	Open the shut-off valves.
	The condensate inlet or outlet is dirt clogged.	Clean the pipes. Clean the equipment. Replace the membrane regulator capsule and the nozzle insert.
	Steam pressure and condensate flowrates fluctuate considerably. The pressure upstream of the steam trap is too low for the used trap type.	Use a different steam trap type. Contact the manufacturer to find out which trap type is the most suitable for your application.
	The steam trap is undersized.	Use a steam trap with a larger condensate discharge capacity.
	The differential pressure is too small.	Increase the steam pressure. Lower the pressure in the condensate line. Check the size of the condensate line. Install a steam trap with a larger condensate discharge capacity, a pump steam trap or a condensate return unit.
	The distance between the drain point and the steam trap is too small.	Install the uninsulated steam trap approx. 1 - 2 m away from the drain point. Do not insulate the condensate line and lay it with a gradient so that the condensate is free to fall towards the steam trap.
	The condensate line does not have a slight fall from the drain point towards the steam trap. The condensate is lifted upstream of the steam trap.	Lay the condensate line with a gradient so that the condensate is free to fall towards the steam trap. Change the orientation of the condensate line.
	The condensate temperature is higher than the service temperature of the steam trap. The regulator does not open or only with a time delay.	If the steam trap of the condensate line is insulated remove the insulation. Use a different steam trap type.

Fault	Cause	Remedy
	Insufficient deaeration.	Provide additional deaeration. Use a different steam trap type. Contact the manufacturer to find out which trap type is the most suitable for your application.
Fluid escapes (equipment is leaking).	The end connections are untight.	Seal off the end connections (e. g. flanged or screwed ends).
	A gasket on the body is defective.	Replace the gasket with a new one.
	The body has been damaged by corrosion or erosion.	Check the resistance of the body material for the fluid used. Use a steam trap made from a material that is suitable for the fluid used.
	The body has been damaged by frost.	Replace the equipment with a new one. When shutting down the installation make sure that the condensate lines and the steam trap are completely drained.
	The body has been damaged by waterhammer.	Replace the equipment with a new one. Take appropriate measures to protect the equipment against waterhammer, e. g. by installing suitable non-return valves.

- If faults occur that are not listed above or cannot be corrected, please contact our Technical Service or authorized agency in your country.

Putting the equipment out of operation

Removing harmful substances



DANGER

If the equipment is used in contaminated areas there is a risk of severe injuries or death caused by harmful substances in or on the equipment.

- Only qualified personnel are allowed to perform work on contaminated equipment.
- Always wear the protective clothing prescribed for contaminated areas when working on the equipment.
- Make sure that the equipment is completely decontaminated before carrying out any service work.
- Follow the pertinent instructions for handling the hazardous substances in question.

Qualified personnel must have extensive experience with and a working knowledge of:

- ◆ pertinent rules and regulations concerning handling hazardous substances
- ◆ special regulations for handling the hazardous substances encountered on site
- ◆ using the required personal protective equipment (PPE) and clothing



Caution

Environmental damage may be caused by poisonous fluid residues.

- Before disposing of the equipment make sure that it is clean and free of fluid residues.
- For the disposal of all materials observe the pertinent legal regulations concerning waste disposal.

- Remove all residues from the equipment.
- For the disposal of all residues observe the pertinent legal regulations concerning waste disposal.

Removing the equipment



DANGER

Personnel working on pipes are exposed to safety risks and may suffer severe injuries, poisoning or even loss of life.

- Make sure that no hot or hazardous fluid is in the equipment or the pipes.
- Make sure that the pipes upstream and downstream of the equipment are depressurised.
- Make sure that the installation is switched off and protected against unauthorised or unintended activation.
- Make sure that the equipment and the pipes have cooled down to room temperatures.
- Wear protective clothing that is suitable for the fluid and, if necessary, wear protective gear.

For more information on suitable protective clothing and safety gear refer to the safety data sheet of the fluid in question.



CAUTION

Risk of injuries if the equipment falls down.

- When removing the equipment make sure the it is safely held in place and cannot fall down.

Suitable measures are for instance:

- ▶ Equipment that is not too heavy may be supported by a second person.
- ▶ For heavy equipment use suitable lifting equipment of sufficient strength.
- Detach the end connections of the equipment from the pipes.
- Put the equipment onto a suitable base.
- Store the equipment as described on page 10.

Re-using equipment after storage

Observe the following instructions if you want to remove the equipment and use it again somewhere else:

- ▶ Make sure that the equipment is free of any fluid residues.
- ▶ Make sure that all connections are in good condition and leak-free.
- ▶ If necessary re-work welded connections in order to ensure that they are in good working condition.
- Use the equipment only for its intended purpose and the service conditions for which it was specified.

Disposing of the equipment



Caution

Environmental damage may be caused by poisonous fluid residues.

- Before disposing of the equipment make sure that it is clean and free of fluid residues.
- For the disposal of all materials observe the pertinent legal regulations concerning waste disposal.

The equipment is made from the following materials:

MK 45

Component	DIN / EN	ASME
Body and cover	1.0460	A105
Screws	1.7225	A193 B7
Gasket	Graphite/CrNi	
Membrane regulator capsule	Hastelloy®	
Other internals	High grade steels	

MK 45A

Component part	DIN / EN	ASME
Body and cover	1.4404	A182
Bolts	A2-70	A193 B8
Gasket	Graphite/CrNi	
Membrane regulator capsule	Hastelloy®	
Other internals	High grade steels	

Technical data

Dimensions and weights

All types

Height [mm]	132
Width of cover [mm]	96
Space required for removing cover [mm]	30
Space required for removing sealing plug [mm]	30

Equipment with flanged ends

Nominal size DN	EN 1092-1 PN 40			ASME B 16.5 Class 150			ASME B 16.5 Class 300		
	15	20	25	15	20	25	15	20	25
	1/2"	3/4"	1"	1/2"	3/4"	1"	1/2"	3/4"	1"
Overall length [mm]	150		160	150		160	150		160
Diameter of flange [mm]	95	105	115	88.9	98.4	107.9	95.2	117.5	123.8
Weight [kg]	3.7	4.3	4.8	3.7	4.3	4.8	3.7	4.3	4.8

Equipment with butt-weld ends

Nominal size DN	EN 12627 Edge form to ISO 9692, code number 1.3			ASME B 16.25 ASME B 36.10		
	15	20	25	15	20	25
	1/2"	3/4"	1"	1/2"	3/4"	1"
For pipe*	21.3 × 2.0	26.9 × 2.3	33.7 × 2.6	21.3 × 2.8	26.7 × 2.9	33.4 × 3.4
Overall length [mm]	200					
Weight [kg]	2.5					

* Butt-weld ends for other pipe sizes available on request.

Equipment with socket-weld and butt-weld ends

Socket-weld ends to DIN EN 12760, ASME B 16.11 Class 3000 Butt-weld ends to G: ISO 228-1, NPT: ASME B 16.11			
Nominal size DN	15	20	25
	1/2"	3/4"	1"
Overall length [mm]	95		
Weight [kg]	2.2	2.1	2.0

Pressure & temperature ratings

Pressure & temperature ratings MK 45

Max. differential pressure Δ PMX: 32 bar

End connection	Flanged PN 40, EN 1092-1					
PMA (admissible service pressure) [barg]	40.0	33.3	27.6	25.7	23.8	13.1
TMA (admissible temperature) [°C]	-10/20	200	300	350	400	450

End connection	Flanged Class 150, ASME B16.5					
PMA (admissible service pressure) [barg]	19.6	13.8	10.2	8.6	6.5	5.5
TMA (admissible temperature) [°C]	-29/38	200	300	345	400	425

End connection	Flanged to Class 300, ASME B16.5, Butt-weld ends to EN 12627, Socket-weld ends to EN 12760, Socket-weld ends to Class 3000, ASME B16.11, Screwed sockets to G, ISO 228-1, Screwed sockets to NPT, ASME B16.11					
Pressure ¹ p [bar]	51.1	43.8	39.8	37.8	34.7	28.8
Temperature ¹ T [°C]	-10/38	200	300	345	400	425

¹ Resistance limits for body/cover to ASME B16.5

Pressure & temperature ratings MK 45A

Max. differential pressure Δ PMX: 32 bar

End connection	Flanged PN 40, EN 1092-1					
Pressure ¹ p [bar]	40.0	31.8	29.9	27.6	26.4	25.7
Temperature ¹ T [°C]	-10/20	200	250	300	350	400

1 Resistance limits for body/cover to EN 1092-1

If the operating temperatures exceed 300 °C intercrystalline corrosion may occur. Do not subject the equipment to operating temperatures higher than 300 °C unless intercrystalline corrosion can be ruled out.

End connection	Flanged Class 150, ASME B16.5				
Pressure ¹ p [bar]	15.9	11.2	10.0	8.4	6.5
Temperature ¹ T [°C]	-29/38	200	300	350	400

1 Resistance limits for body/cover to ASME B16.5

If the operating temperatures exceed 300 °C intercrystalline corrosion may occur. Do not subject the equipment to operating temperatures higher than 300 °C unless intercrystalline corrosion can be ruled out.

End connection	Flanged to Class 300, ASME B16.5, Butt-weld ends to EN 12627, Socket-weld ends to EN 12760, Socket-weld ends to Class 3000, ASME B16.11, Screwed sockets to G, ISO 228-1, Screwed sockets to NPT, ASME B16.11				
Pressure ¹ p [bar]	41.4	29.2	26.1	25.1	24.3
Temperature ¹ T [°C]	-10/38	200	300	350	400

1 Resistance limits for body/cover to ASME B16.5

If the operating temperatures exceed 300 °C intercrystalline corrosion may occur. Do not subject the equipment to operating temperatures higher than 300 °C unless intercrystalline corrosion can be ruled out.

Manufacturer's declaration

For more information on the Conformity Assessment according to European rules refer to our Declaration of Conformity or our Declaration by Manufacturer.

To download the current Declaration of Conformity or Declaration by Manufacturer go to www.gestra.com/documents or contact:

GESTRA AG

Münchener Straße 77

28215 Bremen

Germany

Telefon +49 421 3503-0

Telefax +49 421 3503-393

E-Mail info@de.gestra.com

Web www.gestra.de

This declaration is no longer valid if modifications are made to the equipment without consultation with us.



Agencies all over the world: www.gestra.de

GESTRA AG

Münchener Straße 77

28215 Bremen

Germany

Telefon +49 421 3503-0

Telefax +49 421 3503-393

E-Mail info@de.gestra.com

Web www.gestra.de

810348-11/06-2017 kx_mm (808474-09) © GESTRA AG Bremen Printed in Germany